

# 912L LA

TITAN12L/12L1 912L



## Linear actuator

**EN** - Installation and reference manual

**IMPORTANT** - These instructions apply only to the 912L actuator. Control box installation/operation is described in a separate control box manual.

**Nice**

## CONTENTS

<b>SECTION 1: TITAN 912L ACTUATOR OVERVIEW .....</b>	<b>3</b>
<b>SECTION 1: TOOLS NEEDED FOR INSTALLATION .....</b>	<b>4</b>
<b>SECTION 2: INSTALLATION SAFETY .....</b>	<b>4</b>
<b>SECTION 3: ACTUATOR - MECHANICAL INSTALLATION .....</b>	<b>5</b>
3.1 MANUALLY SET GATE OPEN/CLOSE LIMITS .....	12
3.2 RUN ACTUATOR CABLE(S) TO CONTROL BOX .....	13
3.3 936 CONTROL BOARD WIRING: PULL-TO-OPEN .....	14
3.4 936 CONTROL BOARD WIRING: PUSH-TO-OPEN .....	15
3.5 1050 CONTROL BOARD WIRING: PULL-TO-OPEN .....	16
3.6 1050 CONTROL BOARD WIRING: PUSH-TO-OPEN .....	17
3.7 SETTING ACTUATOR FINE LIMITS .....	20
3.8 ACTUATOR CABLE REPLACEMENT WIRING .....	22
<b>SECTION 4: PART DRAWINGS .....</b>	<b>23</b>
<b>Warranty .....</b>	<b>24</b>

### SECTION 1: TITAN 912L ACTUATOR OVERVIEW

Congratulations on selecting a Nice TITAN 912L actuator. With proper selection, system design, installation and maintenance this operator should provide years of reliable operation. This manual covers ONLY the installation of the TITAN 912L actuator.

#### IMPORTANT!

For control box installation, wiring, operation, maintenance instructions and all safety information, refer to the appropriate control box installation manual used for the system being installed.

### TITAN912L ACTUATOR SPECIFICATIONS

<b>Drive</b>	Electromechanical Stainless Steel Screw
<b>Gate Length And Weight Max.</b>	<ul style="list-style-type: none"> <li>Up to 600 lb. for 20 foot leaf (272 kg for 6 m)</li> <li>Up to 1000 lb for an 8 ft leaf (453 kg for 2.4 m)</li> </ul>
<b>Open/Close Time (To 90°)</b>	14 - 16 seconds (adjustable)
<b>Temperature Rating</b>	-4° to 122° F (-20° to 50° C)
<b>Operating Voltage</b>	12VDC
<b>Actuator Dimensions (LxWxD)</b>	43 x 4 x 6.75 inches (109.2x 10x 17.5 cm)
<b>User Controls</b>	936 or 1050 control board
<b>Listed To UI325</b>	936, 1050, or Mercury 310 Control Boards: Usage Class I, II, III, IV
<b>Actuator Weight</b>	19.75 pounds (8.96 kg)

### TITAN912L ACTUATOR PARTS IDENTIFICATION

PART#	DESCRIPTION	QTY
912L-1	Actuator With 12 foot Harness	1
912L-2 (DUAL GATE ONLY)	Actuator With 42 foot Harness	1
1116	Pivot Arm	1
10025215 or PD0959A0000	Gate Bracket (Black)	1
1125	Actuator Bolt Kit	1



- TITAN 912L-1 = Actuator with 12' harness
- TITAN 912L-2 = Actuator with 42' harness (dual gate only)



ACTUATOR BOLT KIT  
(P/N 1125)



PIVOT ARM (P/N 1116)



GATE BRACKET,  
BLACK  
(P/N 10025215)

## SECTION 2: INSTALLATION SAFETY

### IMPORTANT!

- The gate operator installation is NOT a “do-it-yourself” project. Contract a qualified gate operator installation company to install this system to ensure a safe and reliable installation.
- It is the responsibility of the property owner to ensure the installer is qualified to carry out the installation in a safe and professional manner.
- Consult local government agencies for up-to-date rules and regulations to satisfy licensing, codes or regulations that regulate automated gate system design and installation.
- The gate for which the gate operator is intended to be used should itself be installed correctly so that it is level and plumb and the gate opens easily and evenly.
- Note that Nice swing gate systems are not intended for installation on an incline.

### WARNING

**READ ALL SAFETY INFORMATION WHEN INSTALLING A SWING GATE SYSTEM! SEE EITHER OF THE FOLLOWING MANUALS FOR SAFETY INFORMATION:**

- CBOX936 Control Box Installation and Program Manual (with 936 controller).
- CBOX1050 Control Box Installation and Program Manual (with 1050 controller).
- MB1050 Control Box Installation an Program Manual (with 1050 controller).
- ACBOX/SolarBOX Installation and Program Manual (with Mercury 310 controller)

### CAUTION

- Disconnect power at the control panel before making any electric service power connections.
- Be aware of all moving parts and avoid close proximity to any pinch points.

## SECTION 3: TOOLS NEEDED FOR INSTALLATION

Below is a list of tools necessary for installation of the Titan actuator:

- Welder (for pivot arm) unless optional bolt-on pivot arm (P/N 446) is used.
- Basic hand tools (screwdrivers, wrenches, pliers, etc..)
- Torx 25 tool (for removing actuator cover screws)
- Level (for ensuring pivot arm and actuator are level).
- Framing square (for determining pivot arm location)
- Torch/Chop Saw (for cutting pivot arm)
- Grinder (for sanding Pivot Arm)

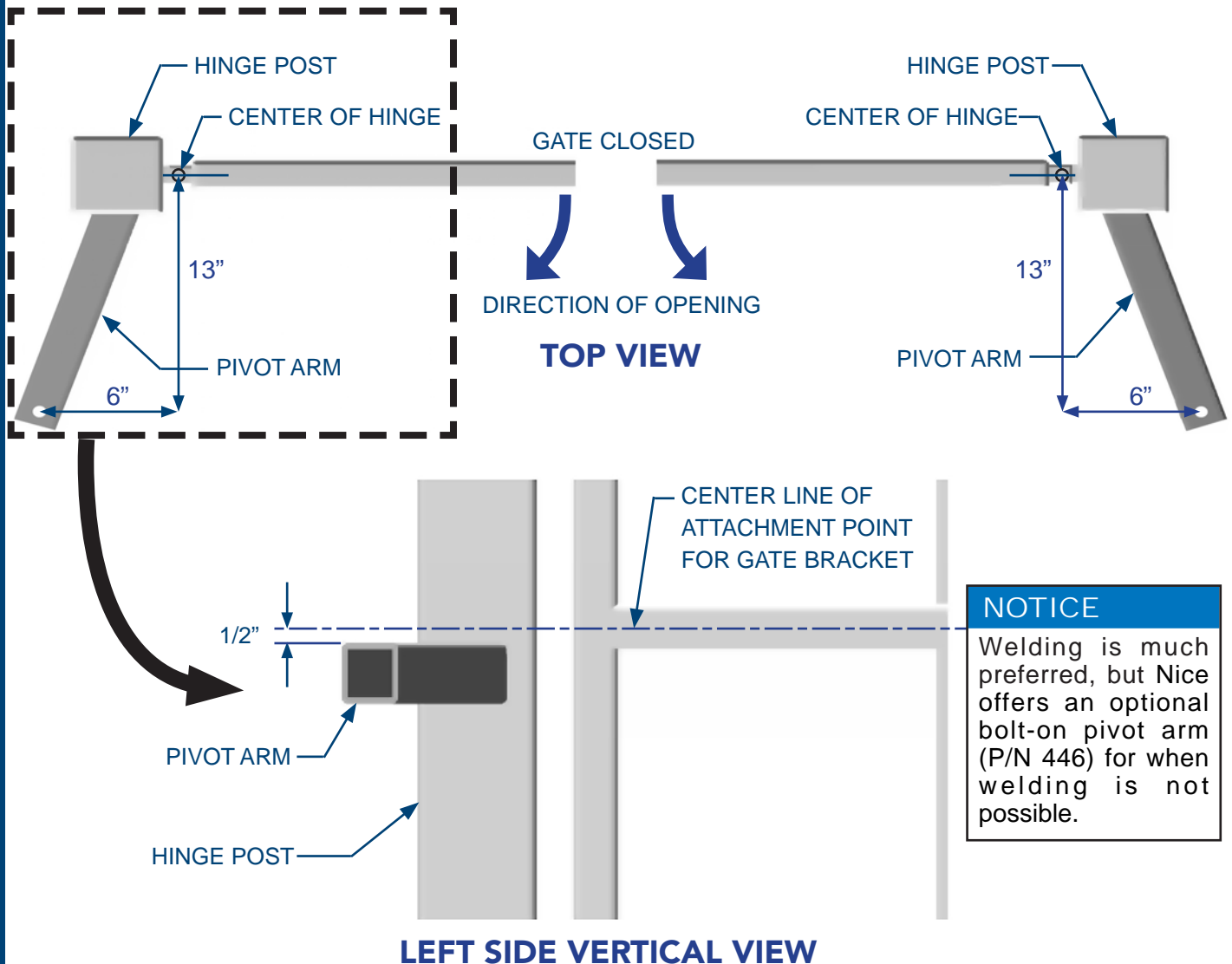
**SECTION 4: ACTUATOR - MECHANICAL INSTALLATION**

**1A INSTALL PIVOT ARM TO GATE: PULL-TO-OPEN**

1. Securely mount the pivot arm to the hinge post (FIG-1A).
2. If necessary, cut pivot arm for correct placement of the actuator mounting hole. Measurements are taken from the center of pivot of the gate hinge.
3. It is strongly recommended to weld the pivot arm to the hinge post.

**CAUTION**

Never weld parts to the gate or posts when the control board is powered to avoid irreparable damage to the circuit board!



**NOTICE**  
Welding is much preferred, but Nice offers an optional bolt-on pivot arm (P/N 446) for when welding is not possible.

**FIG-1A: "PULL TO OPEN" PIVOT ARM INSTALLATION**

### 1B INSTALL PIVOT ARM TO GATE: PUSH-TO-OPEN

1. Securely mount the pivot arm to the hinge post (FIG-1B).
2. If necessary, cut pivot arm for correct placement of the actuator mounting hole. Measurements are taken from the center of pivot of the gate hinge.
3. It is strongly recommended to weld the pivot arm to the metal post.

#### ⚠ CAUTION

Never weld parts to the gate or posts when the control board is powered to avoid irreparable damage to the circuit board!

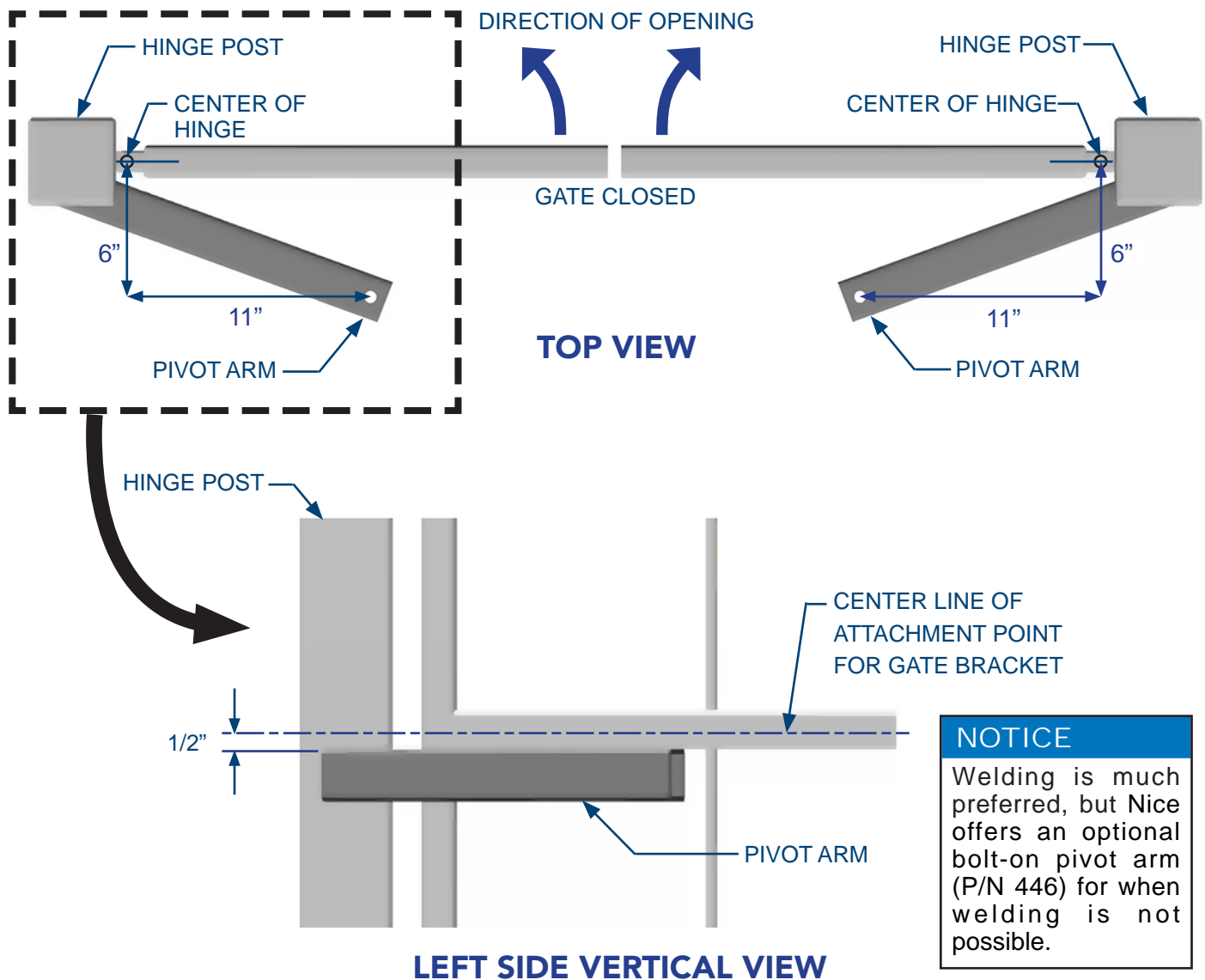


FIG-1B: "PUSH TO OPEN" PIVOT ARM INSTALLATION

## 2 MOUNT ACTUATOR TO PIVOT ARM

1. Mount actuator to pivot arm as shown in FIG-2A using 1/2" bolt and lock nut. Tighten until secure.

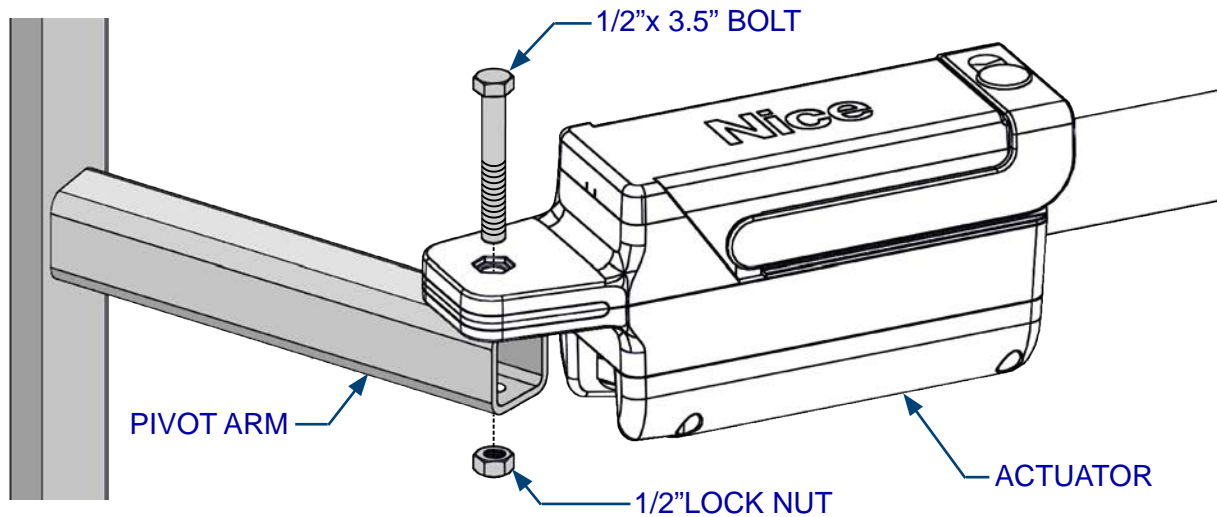


FIG-2A: **INSTALLING ACTUATOR TO PIVOT ARM**

2. Use bubble level to ensure actuator is level and plumb in both open and closed positions.

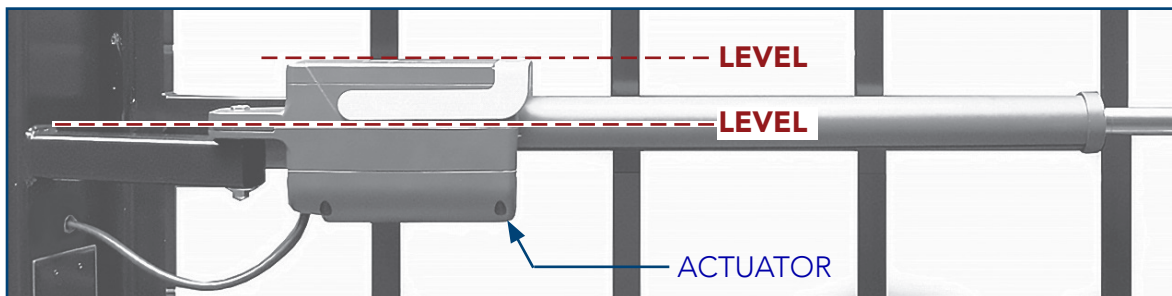


FIG-2B: **LEVEL ACTUATOR (GATE OPEN)**

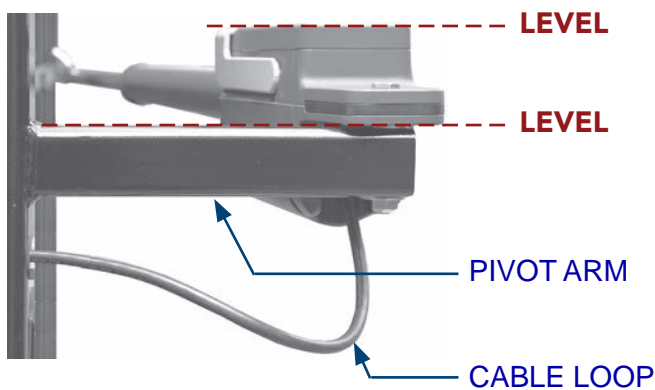


FIG-2C: **LEVEL ACTUATOR (GATE CLOSED)**

### IMPORTANT!

- When using a bubble level to ensure pivot arm/ actuator are plumb and level, check in both open and close positions per FIG-2B and 2C.
- Ensure that actuator mounting hardware is tight enough to prevent movement, vibration, wobble, or shifting when the actuator is in operation.
- Note cable loop (FIG-2C) to allow strain relief for cable during actuator movement.

### 3

## AFFIX GATE BRACKET TO ACTUATOR ARM

If the gate bracket is not already installed on the actuator arm, mount gate bracket to actuator arm with the pivot bolt, nut, and washers per images below.

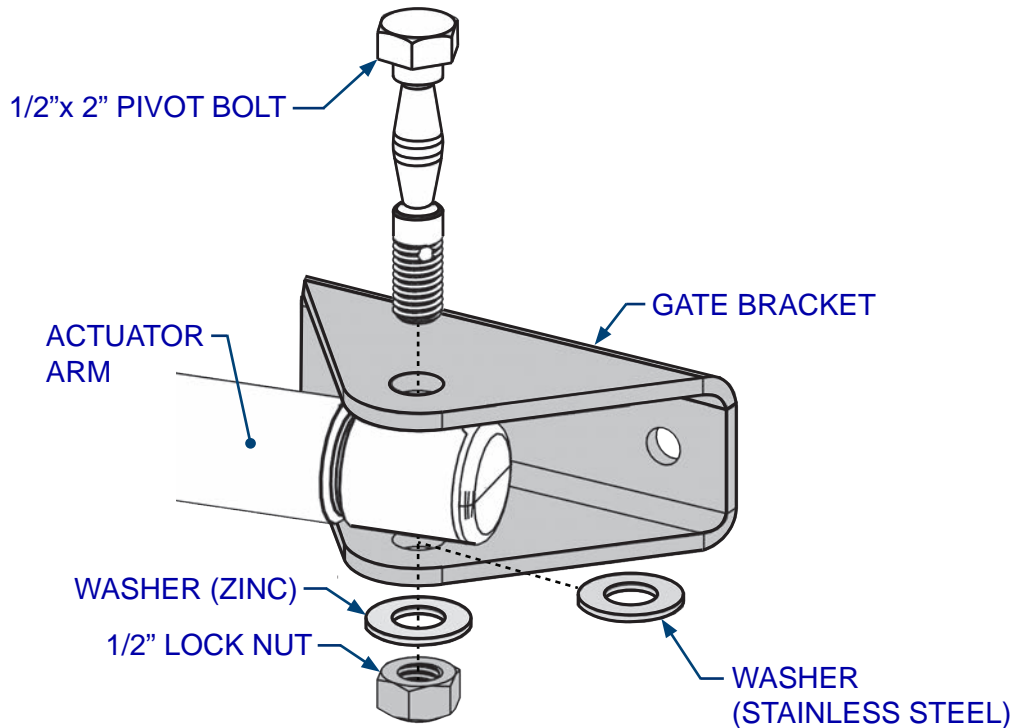


FIG-3A: **AFFIXING GATE BRACKET TO ACTUATOR ARM**

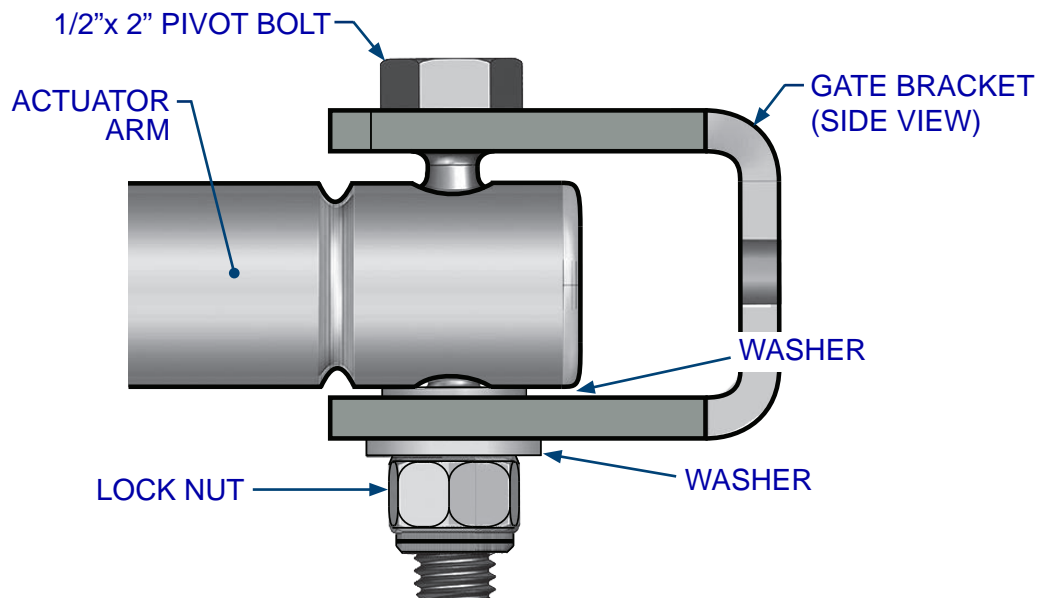


FIG-3B: **GATE BRACKET HARDWARE REQUIREMENTS**



# 4

## POSITION GATE BRACKET ON GATE

1. Place gate in:
  - a) CLOSED position for PUSH-TO-OPEN configurations (FIG-4A).
  - b) OPEN position for PULL-TO-OPEN configuration (FIG-4B).
2. With actuator arm fully retracted, rotate entire actuator on the pivot arm around until the gate bracket attached to the actuator is positioned on a supporting structure of gate.
3. Mark position of gate bracket on gate or clamp into position.

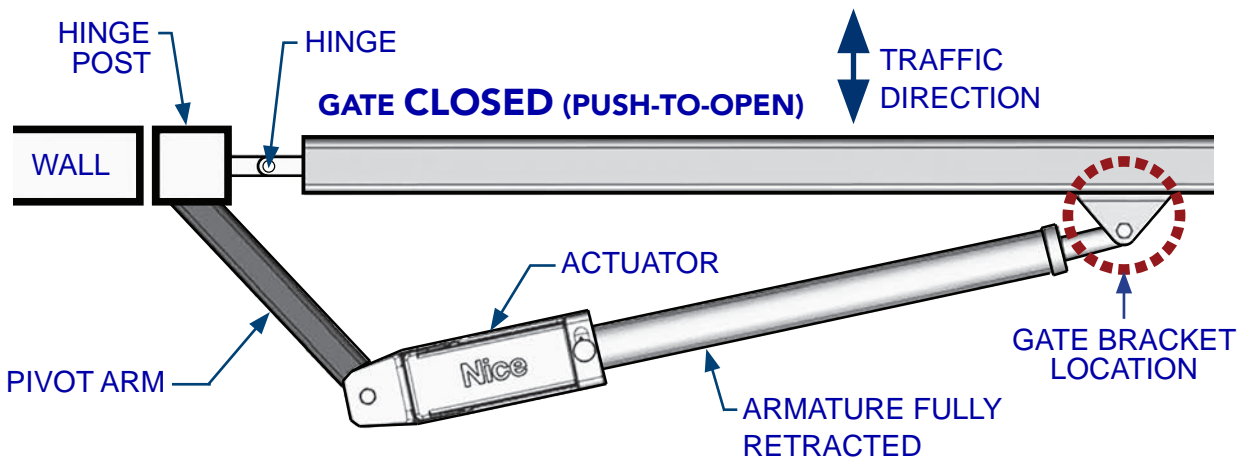


FIG-4A: **PUSH-TO-OPEN GATE BRACKET LOCATION**

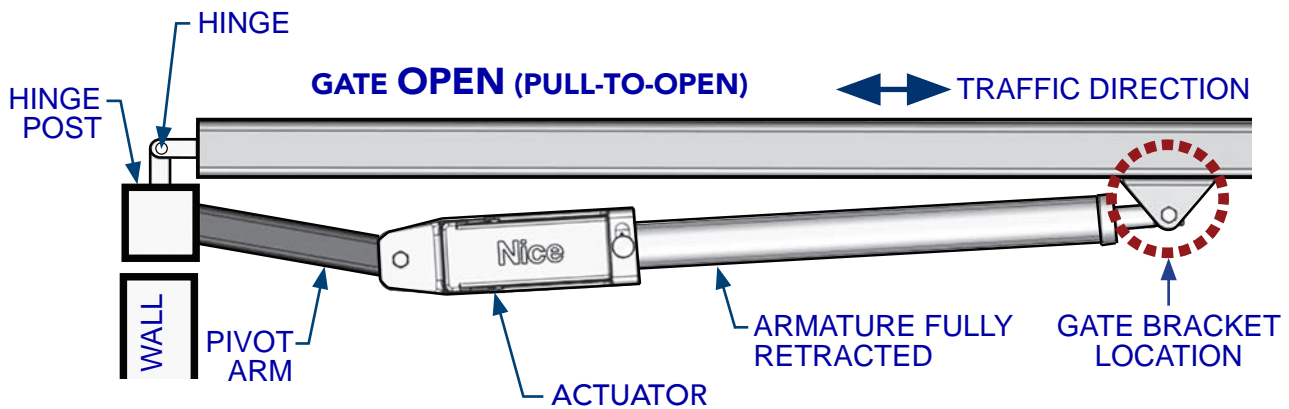


FIG-4B: **PULL-TO-OPEN GATE BRACKET LOCATION**

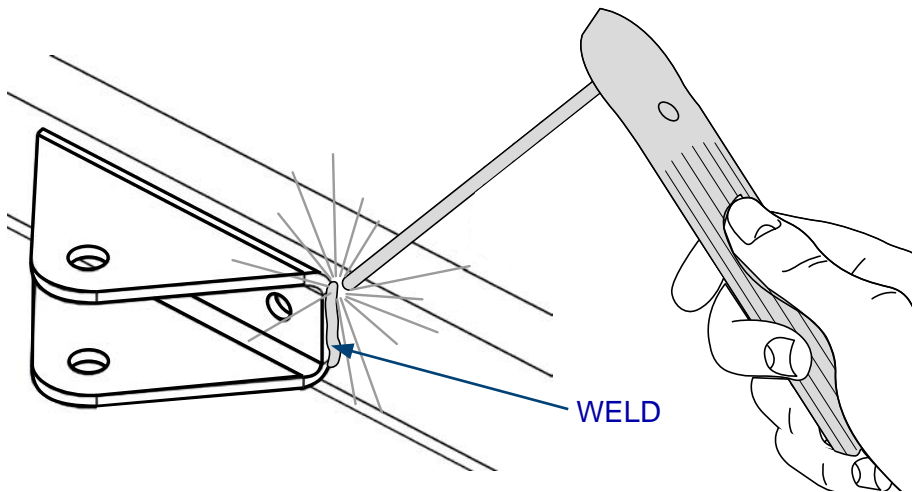
### 5

## AFFIX GATE BRACKET TO GATE

1. Weld the gate bracket to the gate supporting structure (FIG-5A) or use supplied 3/8" bolts and nuts from kit (FIG-5B).

### CAUTION

Never weld parts to the gate or posts when the control board is powered to avoid irreparable damage to the circuit board!



### NOTICE

Attach gate bracket only to structural supports. If unsure of exact bracket location, tack weld or clamp until gate can be tested.

FIG-5A: **GATE BRACKET WELDED TO GATE**

### IMPORTANT!

Ensure bracket centerline is 1/2" above the top of the pivot arm.

2. If welding is not possible, drill two holes to match bracket mounting holes and affix with two 3/8"x2.5" screws and 3/8" nuts included in the kit (FIG-5B).

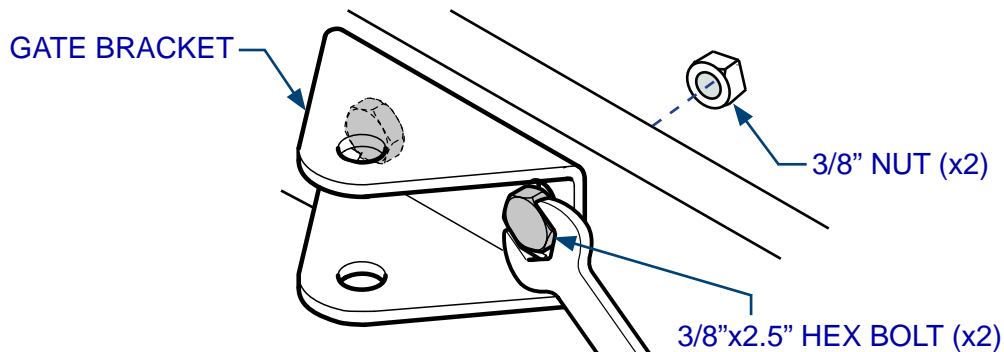


FIG-5B: **GATE BRACKET AND HARDWARE (BLACK BRACKET SHOWN)**

### IMPORTANT!

Use a bubble level to assure after mounting that actuator is level and plumb.

# 6

## OPEN MECHANICAL RELEASE

1. Lift up the rubber key cap (Detail 1).
2. Insert key and turn 90° clockwise (Detail 2).
3. Lift up the mechanical release (Detail 3).
4. After mechanical release is opened, the actuator arm can now be freely extended and retracted manually.

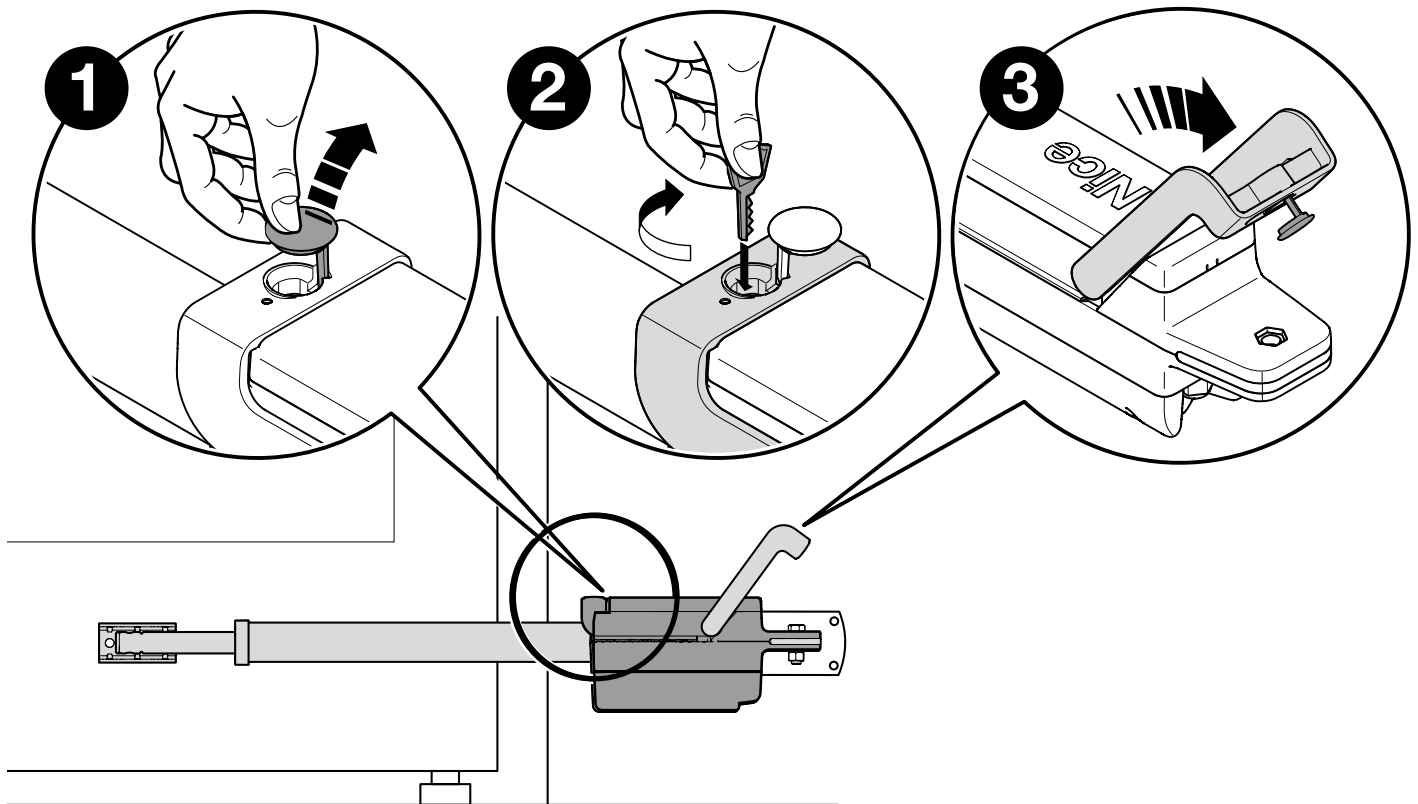


FIG-6: **OPEN ACTUATOR MECHANICAL RELEASE (DETAIL A, B, C)**

### NOTICE

If manual extension is not possible, the actuator must be partially extended using the motor once the actuator is powered by the control board.

To extend actuator using motor, close the mechanical release and momentarily press the OPEN Button (Push-To-Open) or CLOSE Button (Pull-To-Open) to extend the actuator beyond it's fully retracted state, then press the STOP Button. Open the mechanical release again and manual extension should be possible.

### IMPORTANT!

The actuator key **MUST** be left with the customer.

### 4.1 MANUALLY SET GATE OPEN/CLOSE LIMITS

## 7

### SET TITAN 912L OPEN & CLOSE LIMITS

To mechanically “teach” the actuator the rough open and close limits, ensure the mechanical release is still open on the actuator, then move the gate manually as follows:

#### IMPORTANT!

If done carefully, manually setting the gate limits may not require further adjustment. Do not push the gate past the desired limits (open or close) or they must be re-adjusted per Fine adjustment INSTRUCTION 10A or 10B in this manual.

1. Close gate(s) all the way (Detail A) to desired close limit position.
2. Open gate(s) all the way (Detail B) to desired open limit position.
3. Place gates in mid position (Detail C).
4. CLOSE mechanical release of actuator, but do not lock it yet.

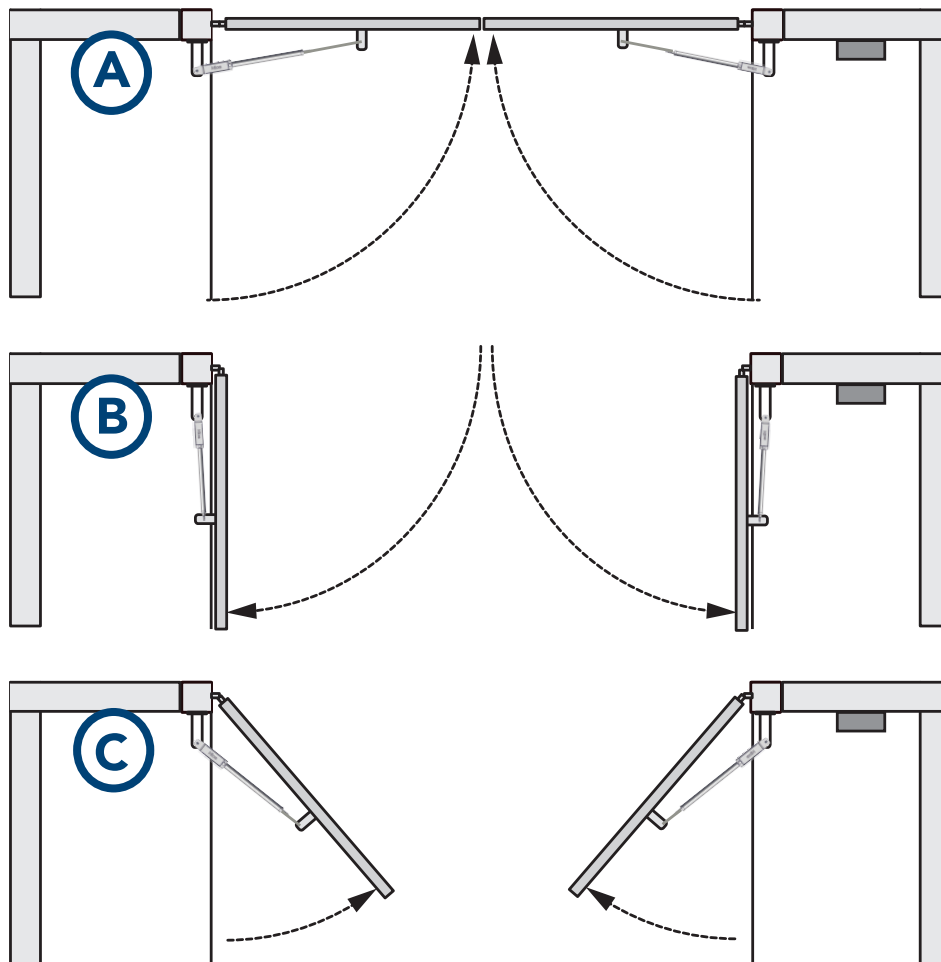


FIG-7: **MANUAL SETTING OF CLOSE/OPEN LIMITS (DETAIL A, B, C)**

## 4.2 RUN ACTUATOR CABLE(S) TO CONTROL BOX

### 8

## RUN ACTUATOR CABLE(S) TO CONTROL BOX

Run the cable of the actuator closest to the control box through a hole (with rubber grommet) drilled in the bottom on the control box. If necessary, entry may be made elsewhere on the control box.

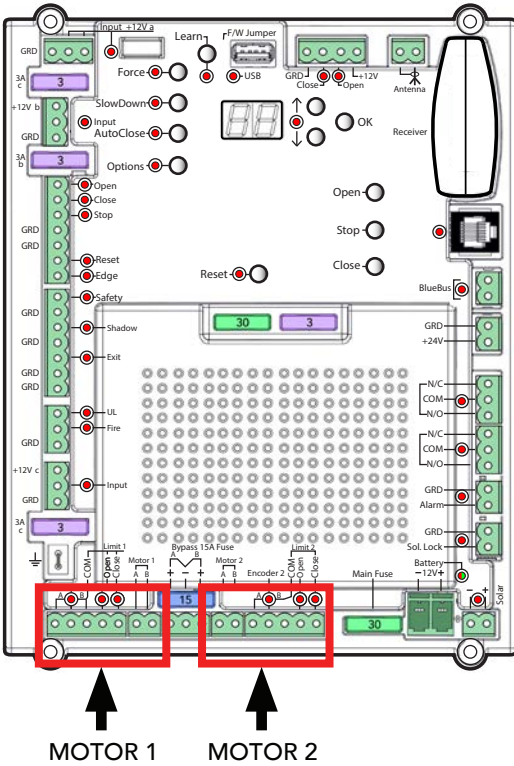
If a dual gate installation:

1. Dig a trench across the driveway deep enough to accommodate the longer harness cable from the actuator farthest from the control box.
2. Run the cable through a conduit and lay this in the trench.
3. Cover the trench and use asphalt patch if needed.
4. Run the 2nd cable into a hole (with rubber grommet) in the bottom of the control box.

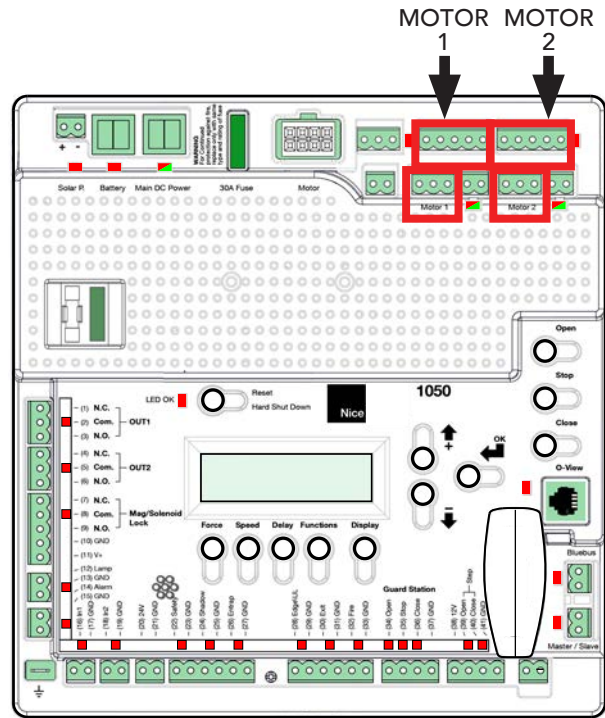
#### NOTICE

Ensure cables reach into the control box sufficiently to reach the MOTOR inputs on the control board.

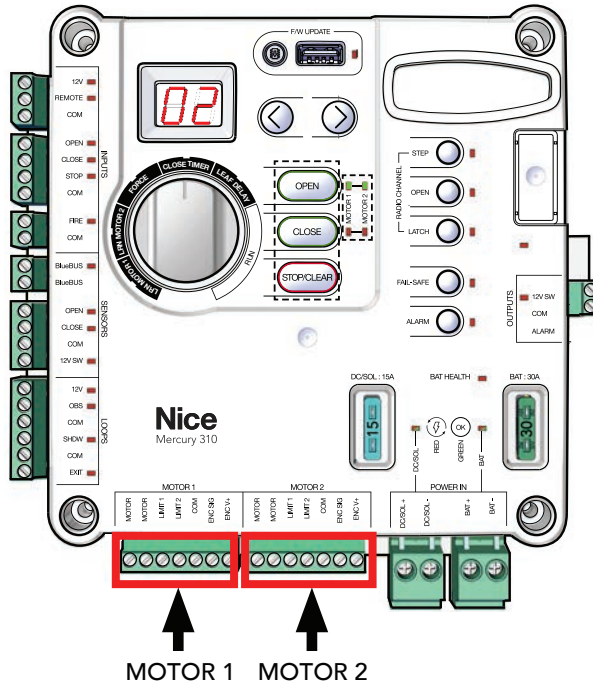
### SECTION 5: TITAN 912L ACTUATOR WIRING



**936 Controller**



**1050 Controller**



**Mercury 310 Controller**

**FIG-9: MOTOR INPUT CONNECTOR LOCATIONS**

### 5.1 936 CONTROL BOARD WIRING: PULL-TO-OPEN

Connect harness wires to MOTOR 1 for your chosen configuration per Instruction 9A, 9B, 9C, or 9D.

#### IMPORTANT!

For dual gate systems, wire the 2nd harness into the connector, but do **NOT** connect it to the control board yet. It will be connected at a later step.

## 9A

### 936 CONTROL BOARD WIRING: PULL-TO-OPEN

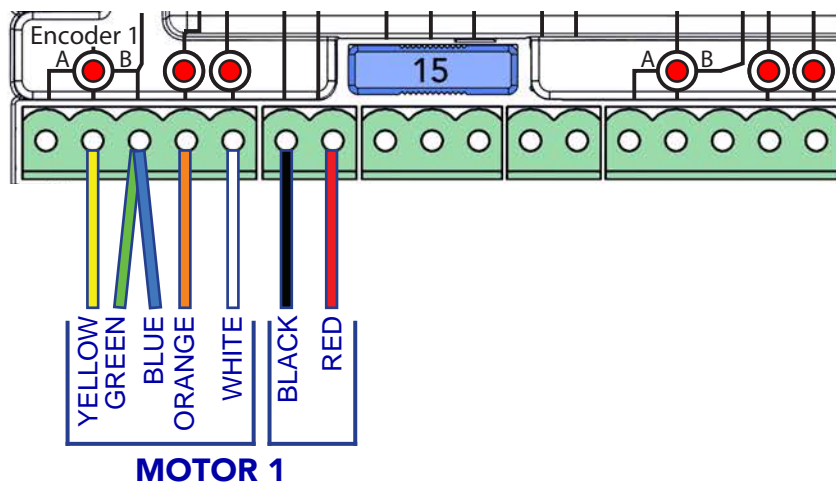
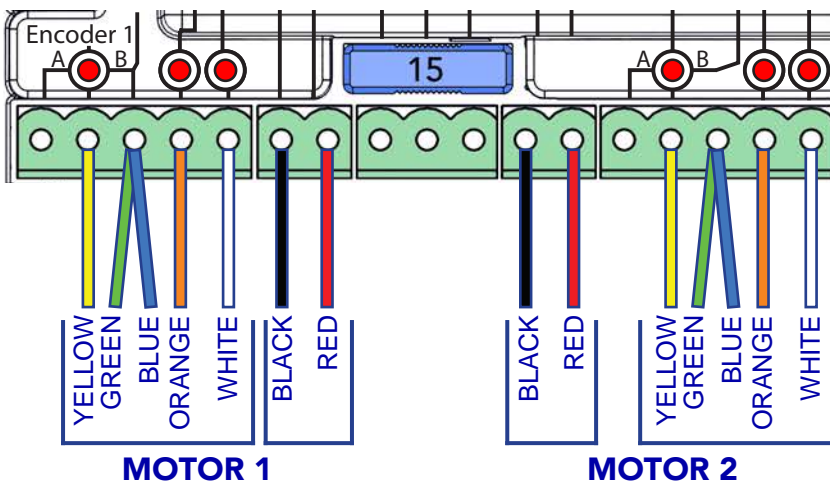


IMAGE 9A-1: **936 BOARD - PULL-TO-OPEN - SINGLE GATE**



#### IMPORTANT!

For dual gate systems, wire the 2nd harness into the connector, but do not connect it to the control board yet. It will be connected at a later step.

← WIRE 2nd  
ACTUATOR WITH  
LONGER HARNESS  
TO MOTOR 2

IMAGE 9A-2: **936 BOARD - PULL-TO-OPEN - DUAL GATE**

### 5.2 936 CONTROL BOARD WIRING: PUSH-TO-OPEN

# 9B

## 936 CONTROL BOARD WIRING: PUSH-TO-OPEN

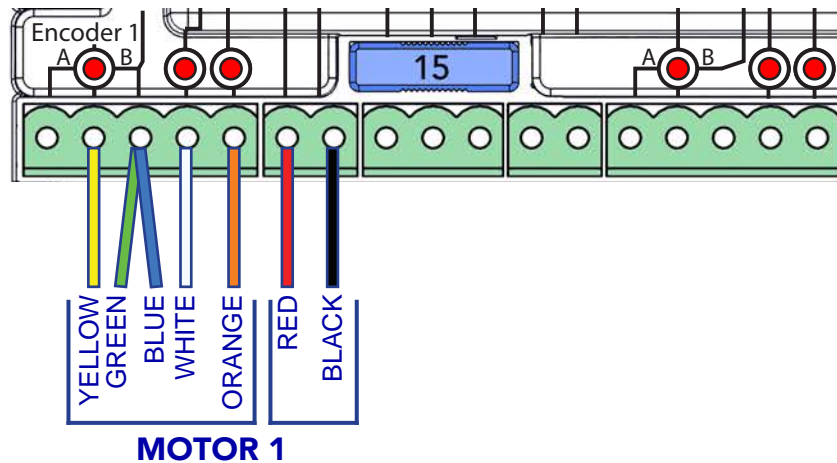
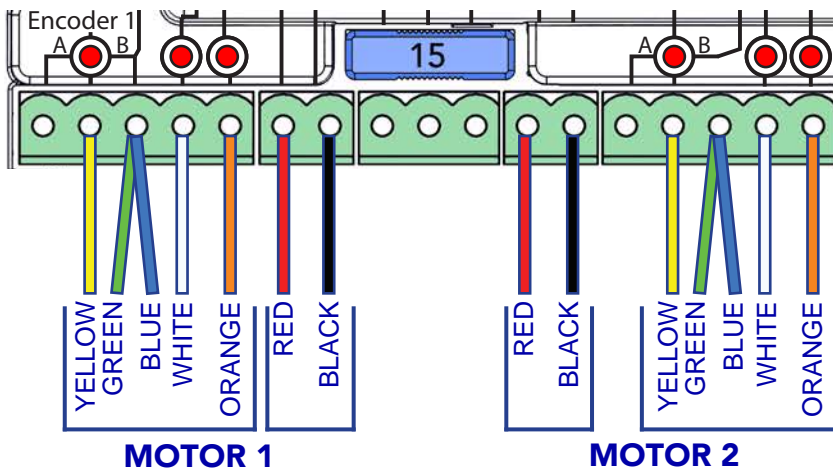


IMAGE 9B-1: **936 BOARD - PUSH-TO-OPEN - SINGLE GATE**



### IMPORTANT!

For dual gate systems, wire the 2nd harness into the connector, but do not connect it to the control board yet. It will be connected at a later step.

← WIRE 2nd  
ACTUATOR WITH  
LONGER HARNESS  
TO MOTOR 2

IMAGE 9B-2: **936 BOARD - PUSH-TO-OPEN - DUAL GATE**

### NOTICE

- If gate moves opposite direction from expected, reverse red & black wires in that motor connector.
- In dual gate systems, the longer actuator cable is usually connected to MOTOR 2, but if the actuator with longer cable has a shorter run time it may be connected to MOTOR 1 instead of MOTOR 2 if the Gate Sync option is used.



## 5.3 1050 CONTROL BOARD WIRING: PULL-TO-OPEN

9C

### 1050 CONTROL BOARD WIRING: PULL-TO-OPEN

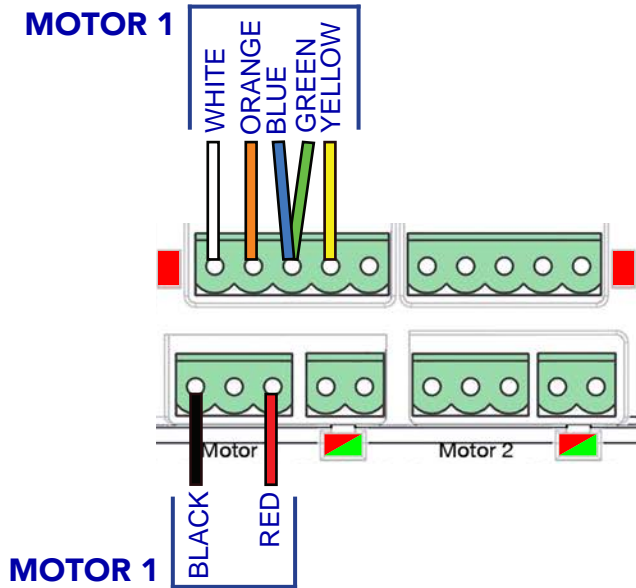


IMAGE 9C-1: 1050 BOARD - PULL-TO-OPEN - SINGLE GATE

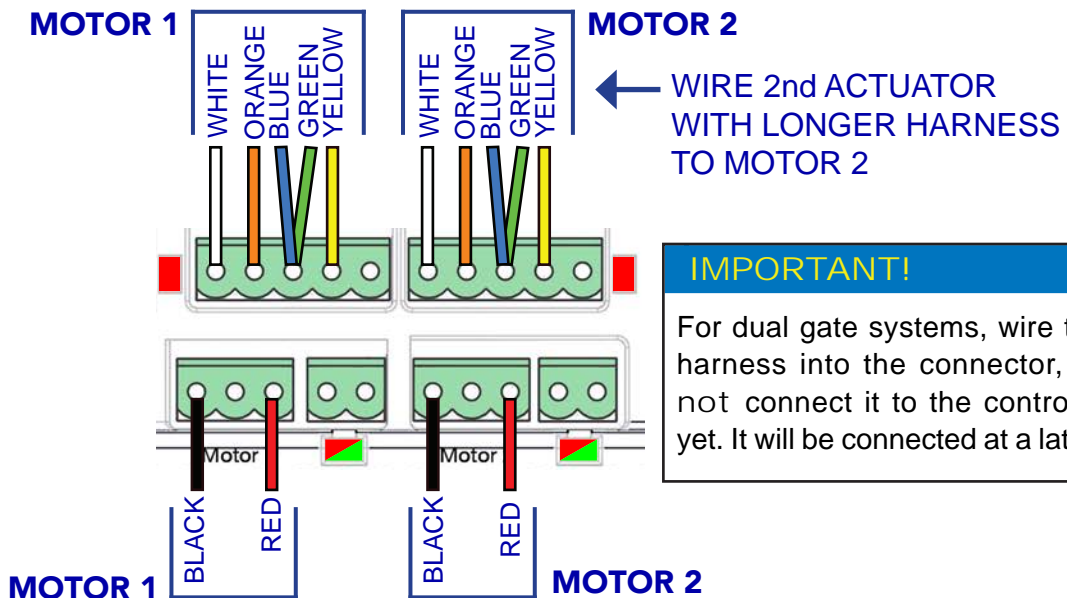


IMAGE 9C-2: 1050 BOARD - PULL-TO-OPEN - DUAL GATE

#### NOTICE

- If gate moves opposite direction from expected, reverse red & black wires in that motor connector.
- In dual gate systems, the longer actuator cable is usually connected to MOTOR 2.

### 5.4 1050 CONTROL BOARD WIRING: PUSH-TO-OPEN

# 9D

## 1050 CONTROL BOARD WIRING: PUSH-TO-OPEN

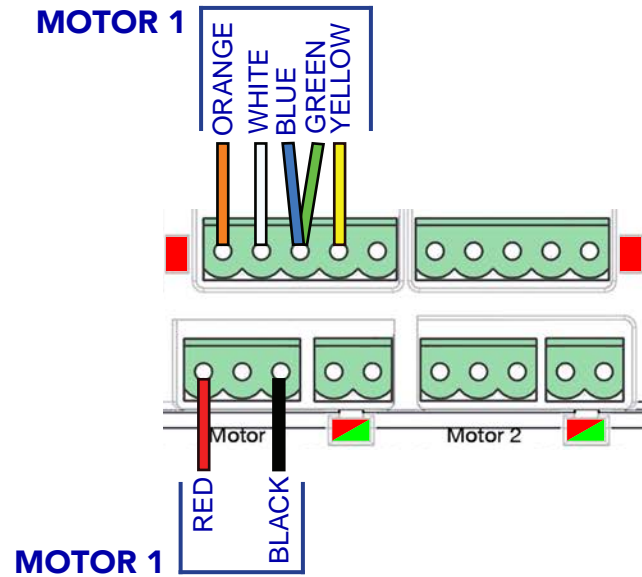


IMAGE 9D-1: 1050 BOARD - PUSH-TO-OPEN - SINGLE GATE

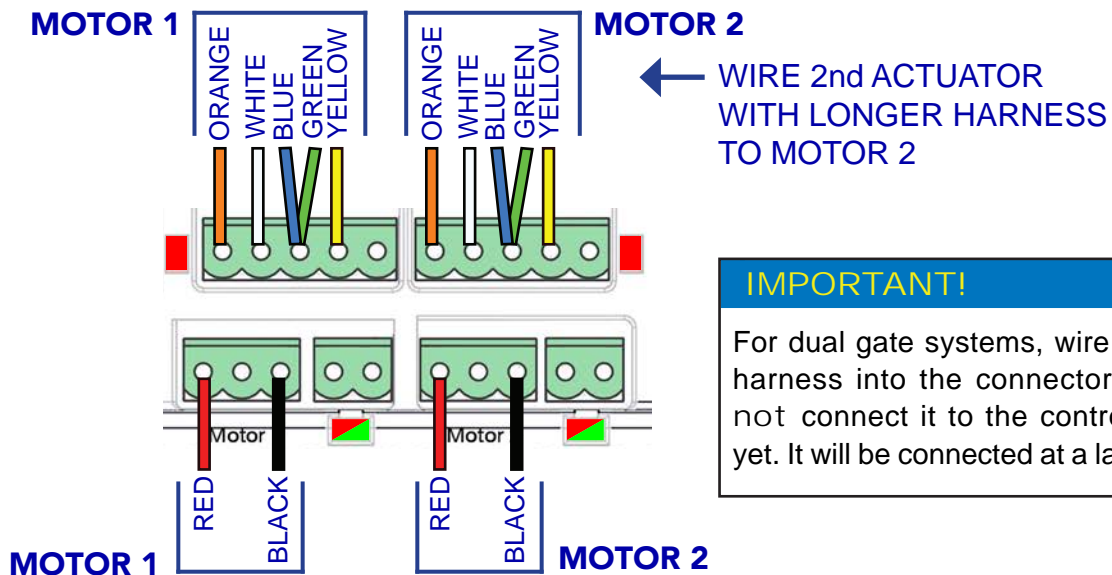


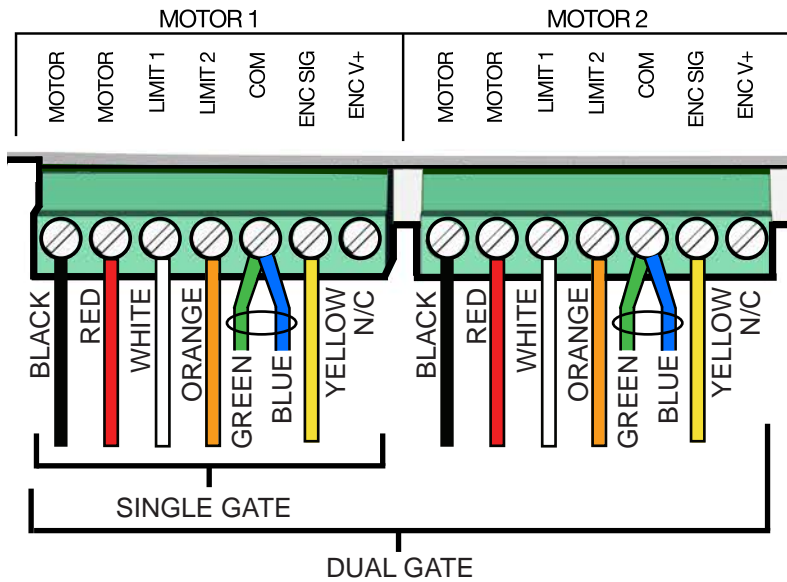
IMAGE 9D-2: 1050 BOARD - PUSH-TO-OPEN - SINGLE GATE

#### NOTICE

- If gate moves opposite direction from expected, reverse red & black wires in that motor connector.
- In dual gate systems, the longer actuator cable is usually connected to MOTOR 2.

9E

MERCURY 310 CONTROL BOARD WIRING



**NOTICE**  
Mercury 310 motor wiring is the same for push-to-open and pull-to-open gate installations.

← WIRE 2nd ACTUATOR WITH LONGER HARNESS TO MOTOR 2

IMAGE 9E: **MERCURY 310 - SINGLE & DUAL GATE WIRING**

### SECTION 6: SETTING ACTUATOR FINE LIMITS

After installation of the control box (per separate installation instructions), the first operation to perform after the board has scanned for monitored safety devices is to ensure the open and close limits are acceptable. Refer to INSTRUCTION 10A or 10B to determine open and close limits. To “teach” limits to the control board, see separate control box installation manual.

#### IMPORTANT: DUAL GATE SYSTEMS!

To set the fine limits for two TITAN 912L actuators in a dual gate system:

1. Plug in only the *primary* actuator to MOTOR 1 input.
2. Determine limits for *primary* actuator per INSTRUCTION 10A or 10B (below).
3. Unplug *primary* actuator from the Motor 1 input.
4. Plug in *secondary* actuator to MOTOR 2 input.
5. Repeat steps in INSTRUCTION 10A or 10B for the secondary actuator.
6. When finished, plug primary actuator back onto MOTOR 1 input.

### 10A SETTING ACTUATOR FINE LIMITS: PULL-TO-OPEN

1. Open the actuator mechanical release, remove two torx 25 screws, and lift off cover.
2. Remove plastic cap covering the two adjustment wheels (IMAGE 10-1).
3. Press the CLOSE button on the control board. The gate should close until it hits the CLOSE limit switch (LED = RED).
4. If the CLOSE limit is not acceptable (gate closed too far or not enough), re-open the gate partially and then turn the turn the EXTEND Adjustment Wheel a few revolutions in “extend more” or “extend less” direction as needed, then press CLOSE button on the Control Board again to check.
5. Check gate and repeat Steps 4-5 as necessary until CLOSE limit is acceptable.
6. Press the OPEN button on control board. The gate should open until it hits the OPEN limit switch (LED = GREEN).
7. If the OPEN limit is not acceptable (gate open too far or not open all the way), re-close the gate partially and then turn the RETRACT Adjustment Wheel a few revolutions in “retract more” or “retract less” direction and press OPEN button on the Control Board again to check.
8. Check gate and repeat Steps 7-8 as necessary until OPEN limit is acceptable.
9. When finished, replace plastic cap on switches, affix actuator cover with two screws, engage mechanical release, and lock.

#### IMPORTANT!

The actuator key **MUST** be left with the customer. The key is necessary to use the mechanical release of the actuator if the gate must be manually opened in the event of loss of power.

### 10B SETTING ACTUATOR FINE LIMITS: PUSH-TO-OPEN

1. Open the actuator mechanical release, remove two Torx 25 screws, and lift off cover.
2. Remove plastic cap covering the two adjustment wheels (IMAGE 10-1).
3. Press the CLOSE button on the control board. The gate should close until it hits the CLOSE limit switch (LED = RED).
4. If the CLOSE limit is not acceptable (gate closed too far or not enough), open the gate partially and turn the RETRACT Adjustment Wheel a few revolutions in “retract more” or “retract less” direction as needed, then press CLOSE button on the Control Board again to check.
5. Check gate and repeat Steps 4-5 as necessary until CLOSE limit is acceptable.
6. Press the OPEN button on control board. The gate should open until it hits the OPEN limit switch (LED = GREEN).
7. If the OPEN limit is not acceptable (gate open too far or not open all the way), close the gate partially and then turn the EXTEND Adjustment Wheel a few revolutions in “extend more” or “extend less” direction and press OPEN button on the Control Board again to check.
8. Check gate and repeat Steps 7-8 as necessary until OPEN limit is acceptable.
9. When finished, replace plastic cap on switches, affix actuator cover with two screws, engage mechanical release, and lock.

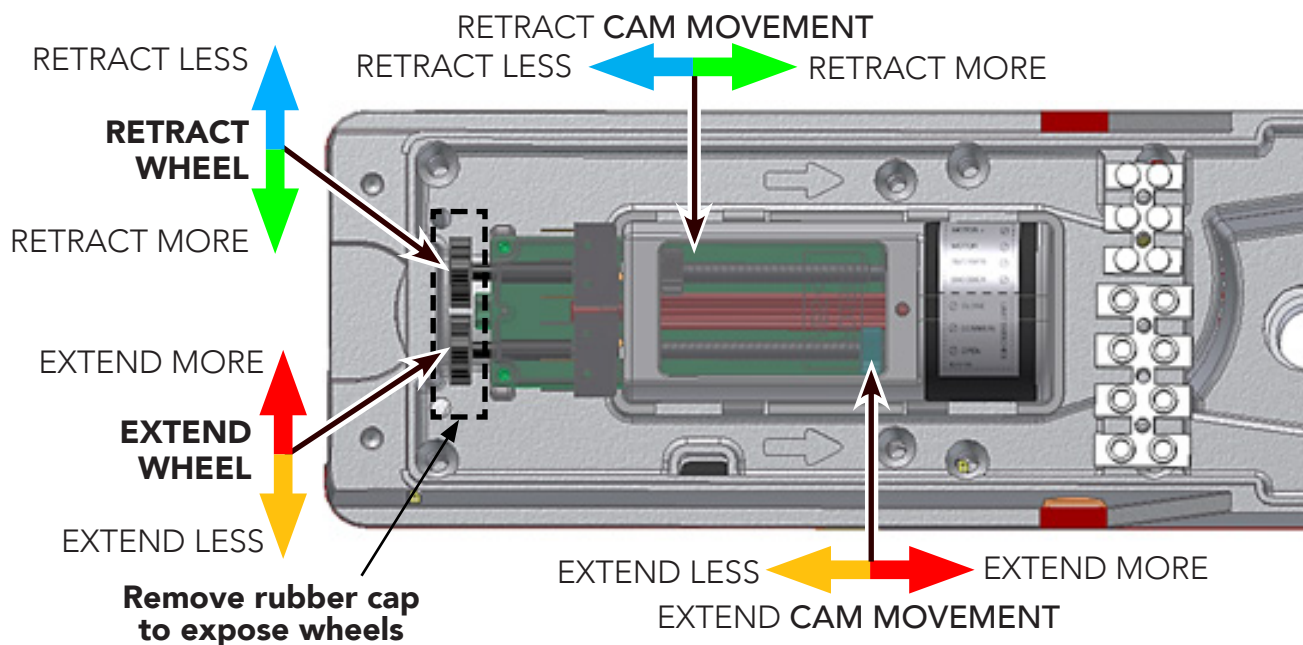


IMAGE 10-1: **TITAN1 ACTUATOR LIMIT SWITCH LOCATIONS & FUNCTIONS**

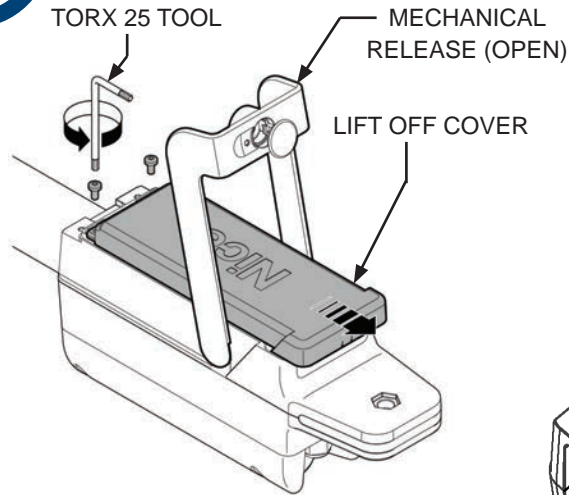
#### IMPORTANT!

The actuator key **MUST** be left with the customer. The key is necessary to use the mechanical release of the actuator if the gate must be manually opened in the event of loss of power.

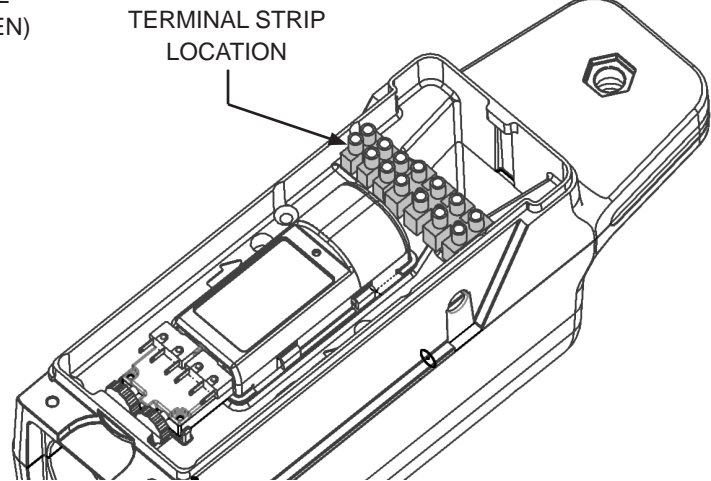
### SECTION 7: ACTUATOR CABLE REPLACEMENT WIRING

## 11

## ACTUATOR CABLE REPLACEMENT WIRING

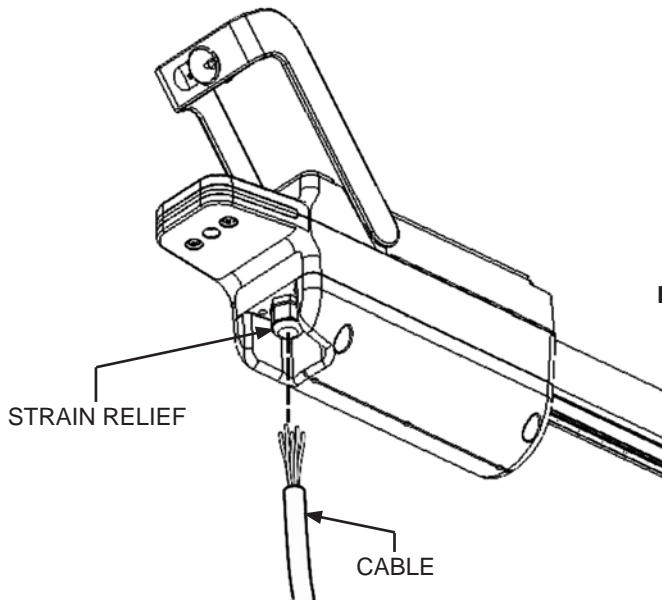


**IMAGE 11-1: REMOVE COVER**

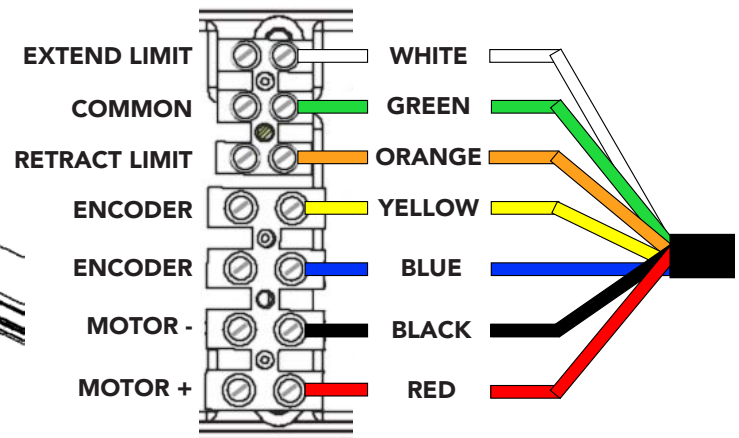


**IMAGE 11-2: LOCATE TERMINAL STRIP**

1. Open mechanical release, remove two Torx 25 screws, and lift off cover (IMAGE 11-1).
2. Locate terminal strip per IMAGE 11-2.



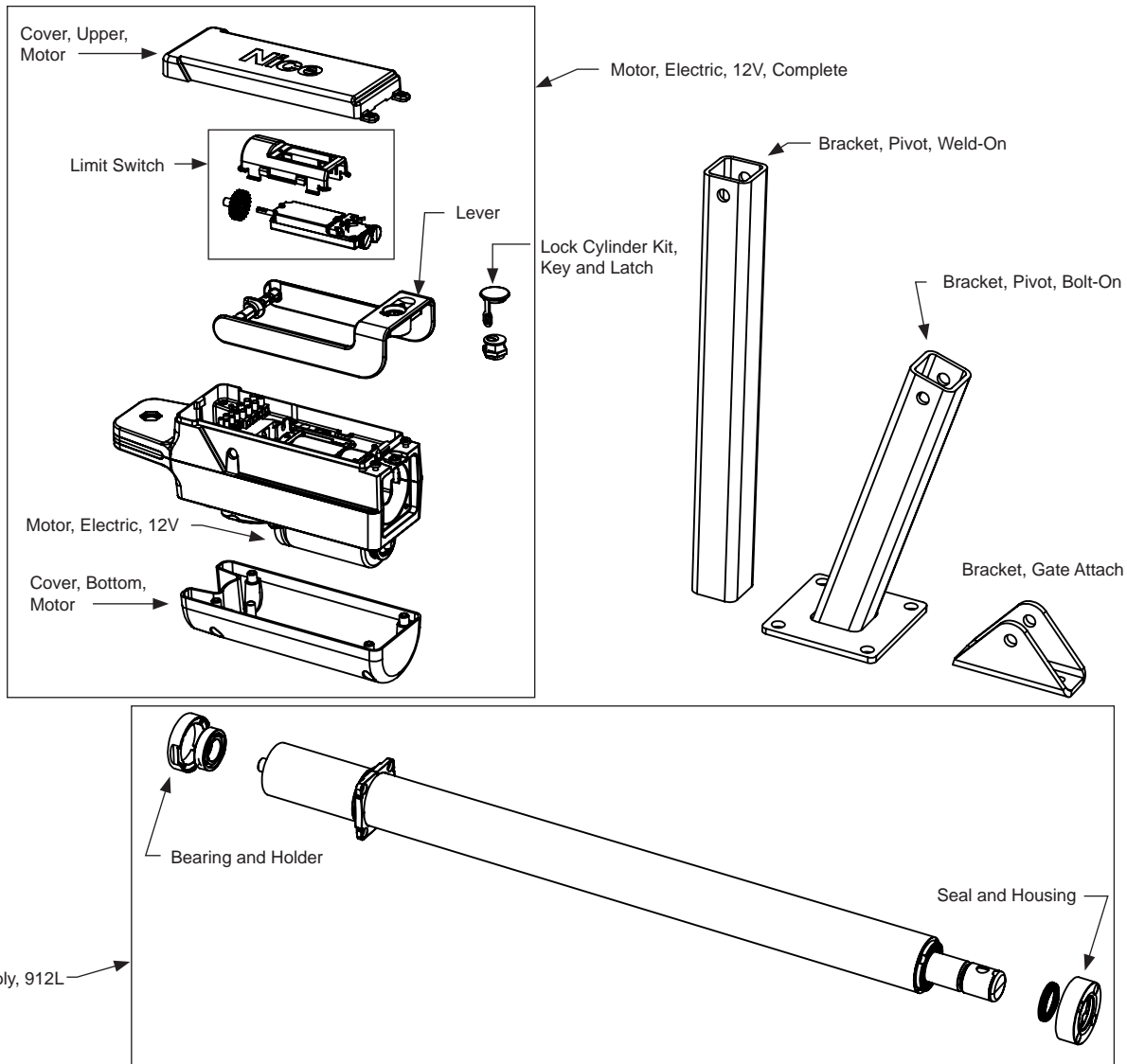
**IMAGE 11-3: CABLE INSERTION**



**IMAGE 11-4: CABLE/TERMINAL STRIP WIRING**

3. Unscrew old wires from terminal strip, loosen strain relief, and pull out cable per IMAGE 11-3.
4. Insert new cable into strain relief per IMAGE 11-3 and strip each wire back 1/8" and twist.
5. Screw stripped colored cable wires into actuator terminal strip as shown in IMAGE 11-4.
6. Tighten strain relief, affix cover, close mechanical release, and lock.

### SECTION 8: PART DRAWINGS



Part Name	Part Number	TITAN12L/12L1 Models
Bearing and Holder	SPTA16002	all
Bracket, Gate Attach, 1/4 inch (Black or Anodized)	10025215 or PD0959A0000	all
Bracket, Pivot, Bolt-On	446	all
Bracket, Pivot, Weld-On	1116	all
Cover, Motor, Bottom	PD0929A3000	all
Cover, Upper	PD0942A3000	all
Lever	SPTA16001	all
Limit Switch	SPSWLSM-01	all
Lock Cylinder Kit, Key and Latch	10070000	all
Motor, Electric, 12V	SPSW912-01	all
Motor, Electric, 12V, Complete	SPAMG205A00	all
Seal and Housing	SPTA16003	all
Tube, Assembly, 912L	SPAMG206A00	all

### LIMITED WARRANTY—NICE-BRANDED PRODUCTS

#### 1. Warranty.

Hy-Security Gate, Inc. (“HySecurity”) warrants that at the time of sale, each Nice-branded gate operator product that it sells will, in all material respects, conform to the then applicable specification for the product and will be free from defects in material and manufacture.

The following additional durational warranties apply to products purchased through a distributor authorized by HySecurity to sell Nice products (“Authorized Distributor”), depending on whether (1) the product is purchased through an Authorized Distributor and (2) whether a timely and complete product registration is submitted to HySecurity.

*It is therefore important that you register your product with HySecurity, online at [www.hysecurity.com/warranty](http://www.hysecurity.com/warranty), within the 60-day period described below.*

#### 1(a) Nice-branded Products Purchased Through Authorized Distributors and Properly Registered

For any gate operator product that is purchased from an Authorized Distributor (this excludes product purchased through internet resellers or any distributor not authorized by HySecurity to sell Nice products), if the product registration is completed by the Dealer/Installer or End User within 60 days of the date of purchase, the following warranty terms will apply. HySecurity warrants that the product will remain serviceable for the following periods:

- a) Electromechanical pad-mounted Slide and Swing operators: Three years after the date of installation,
- b) Electromechanical linear actuator Swing operators: Three years after the date of installation,
- c) Electromechanical barrier arm operators: Three years after the date of installation,
- d) Nice-branded accessories: Three years after the date of installation, *provided that* the Three-Year warranty period in (a), (b), or (c) will not extend beyond four years from the date that the product was shipped from HySecurity.

The preceding warranty durations do not apply to the products or components described below (e-f), which have a shorter warranty period:

- e) Batteries: One Year from date of shipment from HySecurity.
- f) Components subject to normal wear including, but not limited to, chains, belts, idler wheels, sprockets and fuses: One Year from date of installation.

#### 1(b) Nice Products Not Purchased Through an Authorized Distributor or Not Properly Registered within 60 Days

For any product that is not purchased from an Authorized Distributor or for which the product registration was not completed by the Dealer/Installer/End User within sixty (60) days of the date of purchase, the following **Two-Year Limited Warranty** will apply: HySecurity warrants that the product will remain serviceable for Two Years from the date that the product was shipped from HySecurity.

#### 1(c) Replacement Parts

HySecurity warrants that replacement parts (whether new or reconditioned) will remain serviceable for One Year from the date that the part was shipped from HySecurity or the remaining period of the Gate Operator warranty, whichever is longer.

#### 1(d) Limitations and Exclusions Applicable to Each of the Preceding Warranties.

The preceding warranties shall not apply to equipment that has been (1) installed, maintained, or used improperly or contrary to instructions; (2) subjected to negligence, accident, vandalism, or damaged by severe weather, wind, flood, fire, terrorism or war; or (3) damaged through improper operation, maintenance, storage or abnormal or extraordinary use or abuse. Any modification made to products will void the warranty unless the modifications are approved in writing by HySecurity in advance of the change (this exclusion does not apply to normal installation of approved accessories and/or protective devices or sensors). It is the responsibility of the Distributor, Dealer/Installer, or End User to ensure that the software version in the product is maintained to the latest revision level.

The preceding warranties do not extend to accessories when those items carry the name plate of a manufacturer other than HySecurity or Nice and they are not a part of the base model. HySecurity disclaims all warranties for such accessory components, which carry only the original warranty, if any, of their original manufacturer. HySecurity hereby assigns its rights under such manufacturer warranties—to the extent that such rights are assignable—to Buyer.

*This warranty gives you specific legal rights, and you may also have other rights which vary from State to State.*

These warranties extend to HySecurity’s Distributors, to the Dealer/Installer, and to the first End User of the product following installation. They do not extend to subsequent purchasers. **2. Limitation of Certain Implied Warranties and Exclusion of Other Warranties.**

The warranties contained in Section 1 are the exclusive express warranties given by HySecurity and supersede any previous, contrary or additional representations, whether oral or written. Any prior or extrinsic representations or agreements are discharged or nullified. ANY IMPLIED WARRANTIES, INCLUDING ANY WARRANTY OF MERCHANTABILITY OR WARRANTY OF FITNESS FOR A PARTICULAR PURPOSE, ARE LIMITED IN DURATION TO PERIOD OF THE APPLICABLE EXPRESS WARRANTY FOR THE PRODUCT OR COMPONENT. HYSECURITY HEREBY DISCLAIMS AND EXCLUDES ALL OTHER WARRANTIES—INCLUDING ANY LIABILITY FOR INFRINGEMENT, AND ANY WARRANTIES OTHERWISE ARISING FROM COURSE OF DEALING, COURSE OF PERFORMANCE, OR USAGE OF TRADE.

Some states do not allow limitations on how long an implied warranty lasts, so the above limitation may not apply to you.

#### 3. Buyer’s Exclusive Remedies for Any Nonconformity.

If a Nice product fails to conform to the warranties in Section 1, Buyer must notify and order replacement parts from the Distributor through which the product was purchased within a reasonable time and in no event more than thirty (30) days after the discovery of the nonconformity. HySecurity will investigate and, in the event of a breach, will provide, within a reasonable period of time, one of the following: (1) repair or replacement of any nonconforming products or components or (2) refund of the price upon return of the nonconforming items. HySecurity reserves the right to supply used or reconditioned material for all warranty claims. HySecurity will not be considered to be in breach of or default under this Warranty because of any failure to perform due to conditions beyond its reasonable control, including any force majeure. This warranty does not cover any incidental expenses, including fines or penalties, temporary security, labor, shipping, travel time or standby time that are incurred for inspection or replacement of any nonconforming items. As a condition of warranty coverage, warranty claims must be submitted in accordance with the procedures described on the HySecurity form, “RMA Procedures.”

THE REMEDY SELECTED BY HYSECURITY IN ACCORDANCE WITH THIS PARAGRAPH SHALL BE THE EXCLUSIVE AND SOLE REMEDY OF BUYER FOR ANY BREACH OF WARRANTY.

#### 4. Exclusion of Consequential and Incidental Damages.

HYSECURITY AND NICE SHALL NOT BE LIABLE FOR ANY INCIDENTAL, SPECIAL, OR CONSEQUENTIAL DAMAGES, WHETHER RESULTING FROM NONDELIVERY OR FROM THE USE, MISUSE, OR INABILITY TO USE THE PRODUCT OR FROM DEFECTS IN THE PRODUCT OR FROM HYSECURITY’S OR NICE’S OWN NEGLIGENCE. This exclusion applies regardless of whether such damages are sought for breach of warranty, breach of contract, negligence, or strict liability. This exclusion does not apply to claims for bodily injury or death.

Some states do not allow the exclusion or limitation of incidental or consequential damages, so the above limitation may not apply to you.

#### 5. Severability.

If any provision of this warranty is found to be invalid or unenforceable, then the remainder shall have full force and effect.

#### 6. Proprietary Rights.

HySecurity and Nice retain and reserve all right, title, and interest in the intellectual property rights of their products, including any accompanying proprietary software. No ownership of any intellectual property rights in the products or accompanying software is transferred to Distributor, Dealer/Installer, or End User.

#### 7. Applicable Law.

This warranty will be interpreted, construed, and enforced in all respects in accordance with the laws of the State of Washington, without reference to its choice of law principles. The U.N. Convention on Contracts for the International Sale of Goods will not apply to this warranty.