

OAM-EXPLORER

Combination Active Infrared and Microwave Sensor

for Industrial Door Applications



For use in Industrial Door applications, the OPTEX OAM-EXPLORER is both an activation and supplementary safety sensor that improves the safety and efficiency of Industrial Doors. The OAM-EXPLORER uses a large microwave detection area for activation, and infrared technology for safety around the threshold. The sensor can control external devices such as warning lights or alarms in order to warn vehicles and pedestrians on the opposite side of the door. Configuration and fine-tuning can be done via a smart phone app, which means fewer trips up and down a ladder for installers.

Features & Benefits

Superior usability and efficiency

The OAM-EXPLORER was designed with an eye for simplicity and absolute attention to detail. Installation and adjustment time has been minimized. The new screwless design allows for smooth independent angle setting. Compared with conventional industrial door sensors, total installation time is reduced by approximately half.

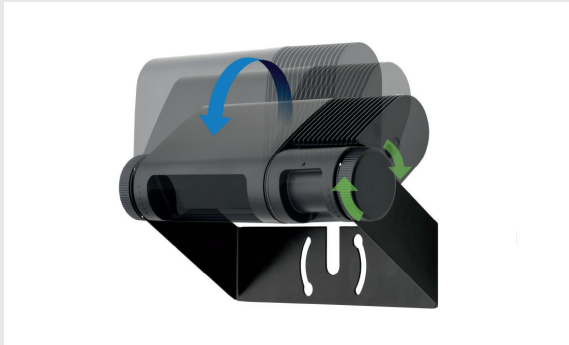

Optimal Installation Flow

Once the OAM-EXPLORER is installed, configuration and the fine tuning are done via the smart phone app. By registering your favorite settings, this feature can also be used in facilities that have multiple industrial doors, or in different facilities. Less time climbing ladders saves installation time and makes for a safer work environment.



Find us in

MasterSpec[®]

Powered by Deltek Specpoint[®]

Detection Area

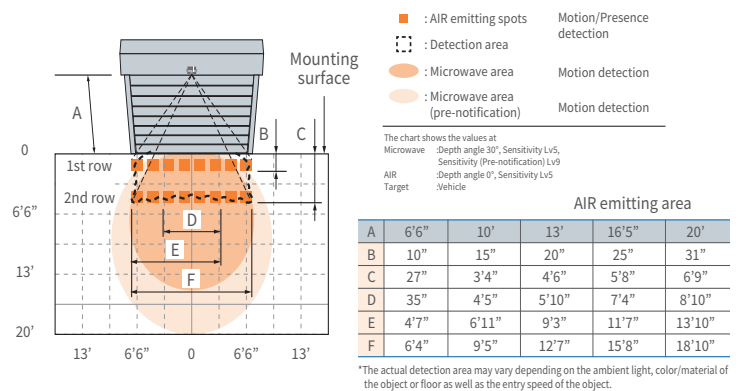

Dimensions

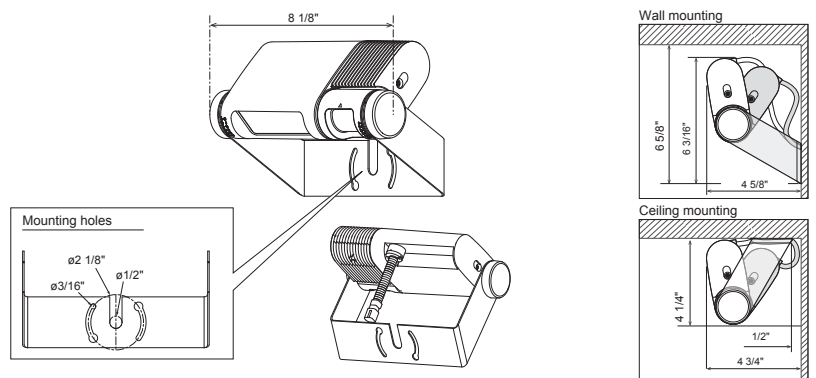

Specifications

Mounting height	6'7" to 19'8"
Detection method	Active infrared reflection (AIR); Microwave doppler effect
Transmitter frequency	24.2GHz
Transmitter radiated power	< 12.7dBm
Depth angle adjustment	Microwave area: 0° to +50°; AIR area: -15° to +40°
Power supply	12 to 24 VAC ±10% (50/60 Hz); 12 to 30 VDC ±10%
Power consumption	<3.5W (<5.0 VA at AC)
Output hold time	Approx. 0.5 sec. (selectable via app.)
Response time	< 0.3 sec. (selectable via app.)
Operating temperature	-31 to 131°F
Operating humidity	<80%
Communication method	Bluetooth LE (Ver. 4.0)
Activation output	Form B relay 50 V 0.3 A Max. (Resistance load)
Supplemental safety output	Form B relay 50 V 0.3 A Max. (Resistance load)
AUX output	Form B relay 50 V 0.3 A Max. (Resistance load)
Protection degree	IP65 / NEMA4
Weight	21.2 oz.
Accessories	1 Operation Manual; 2 mounting screws; 1 mounting template; 1 cable (32'10")

