

# 885

## *Slide Gate Operator*

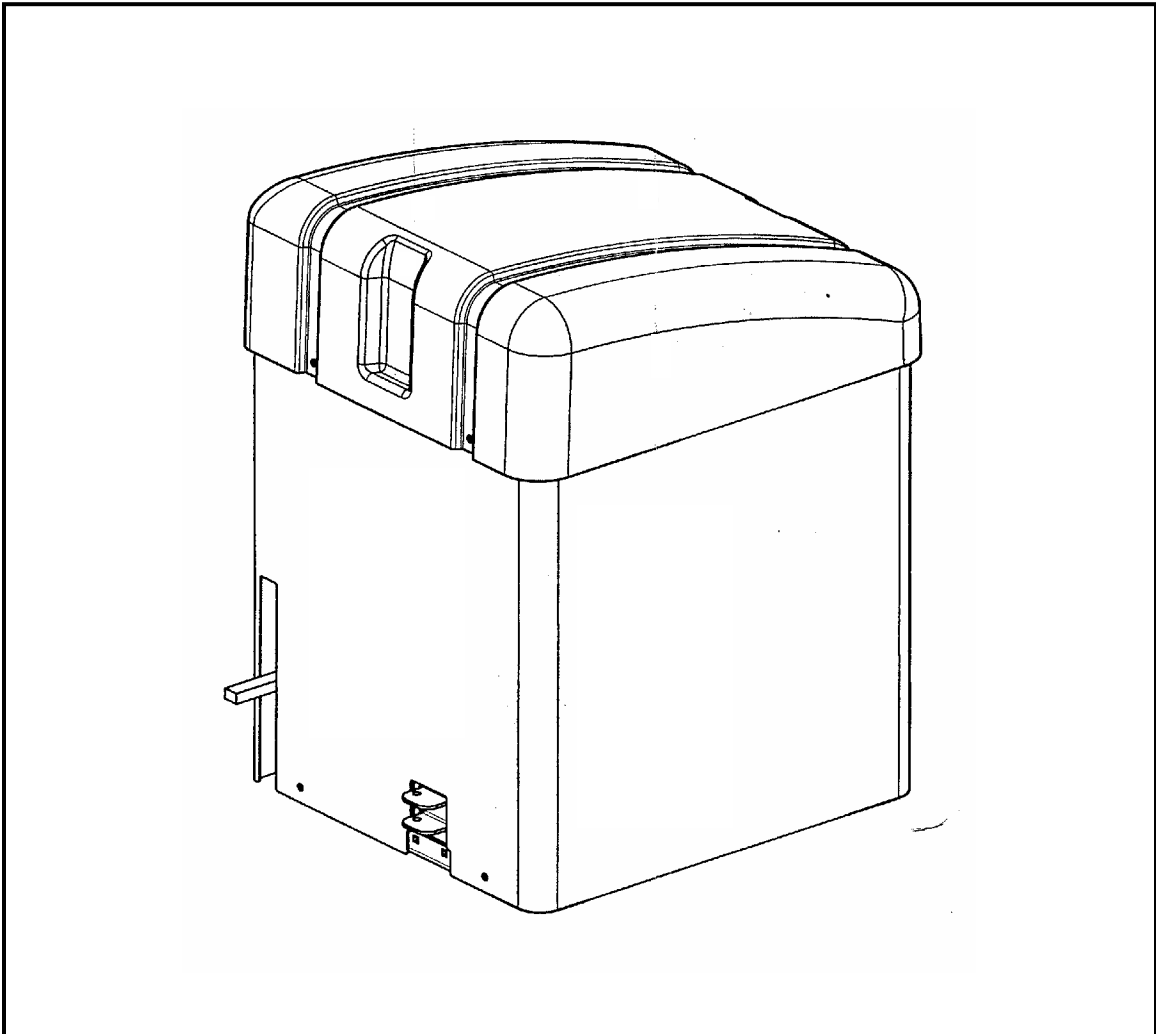

# Important Safety Information

Both the installer and the owner and/or operator of this system need to read and understand this installation manual and the safety instructions supplied with other components of the gate system. The owner and/or operator of the gate should retain this information.

---

**WARNING!** To reduce the risk of injury or death

1. **READ AND FOLLOW ALL INSTRUCTIONS.**
2. Never let children operate or play with gate controls. Keep the remote control away from children.
3. Always keep people and objects away from the gate. **NO ONE SHOULD CROSS THE PATH OF THE MOVING GATE.**
4. Test the gate operator monthly. The gate **MUST** reverse on contact with a rigid object or stop when an object activates the non-contact sensors. After adjusting the force or the limit of travel, retest the gate operator. Failure to adjust and retest the gate operator properly can increase the risk of injury or death.
5. Use the emergency release only when the gate is not moving.
6. **KEEP GATES PROPERLY MAINTAINED.** Read the owner's manual. Have a qualified service person make repairs to gate hardware.
7. The entrance is for vehicles only. Pedestrians must use separate entrance.
8. **SAVE THESE INSTRUCTIONS.**

---

When installing the photo-beams supplied with this unit two things need to be considered.

1. Care should be exercised to reduce the risk of nuisance tripping, such as when a vehicle, trips the sensor while the gate is in motion.
2. One or more photobeams shall be located where the risk of entrapment exists, such as the perimeter reachable by the moving gate leaf.

## Gate Design

1. A gate is a potential traffic hazard, so it is important that you locate the gate far enough away from the road to eliminate the potential of traffic getting backed up. This distance is affected by the size of the gate, how often it is used, and how fast the gate operates.
2. The operator you choose to install on your gate must be designed for the type and size of your gate and for the frequency with which you use the operator.
3. Your gate must be properly installed and must work freely in both directions before the automatic operator is installed.
4. An automatic operator should be installed on the inside of the property/fence line. Do not install the operator on the public side of the property/fence line.
5. Pedestrians should not use a vehicular gate system. Prevent such inappropriate use by installing separate gates for pedestrians.
6. Exposed, reachable pinch points on a gate are potentially hazardous and must be eliminated or guarded.
7. Outward swinging gates with automatic operators should not open into a public area.
8. The operating controls for an automatic gate must be secured to prevent the unauthorized use of those controls.
9. The controls for an automatic gate should be located far enough from the gate so that a user cannot accidentally touch the gate when operating the controls.
10. An automatic gate operator should not be installed on a gate if people can reach or extend their arms or legs through the gate. Such gates should be guarded or screened to prevent such access.

## Installation

1. If you have any question about the safety of the gate operating system, do not install this operator. Consult the operator manufacturer.
2. The condition of the gate structure itself directly affects the reliability and safety of the gate operator.
3. Only qualified personnel should install this equipment. Failure to meet this requirement could cause severe injury and/or death, for which the manufacturer cannot be held responsible.

4. The installer must provide a main power switch that meets all applicable safety regulations.
5. Clearly indicate on the gate with the 2 warning signs that are included (visible from either side of the gate).
6. It is extremely unsafe to compensate for a poorly running gate by increasing the force setting.
7. Devices such as reversing edges and photocells must be installed to provide better protection for personal property and pedestrians. Install reversing devices that are appropriate to the gate design and gate application.
8. Before applying electrical power, be sure that the voltage requirements of the equipment correspond to your supply voltage. Refer to the label on your operator system.

**Use**

1. Use this equipment only in the capacity for which it was designed. Any use other than that stated should be considered improper and therefore dangerous.
2. When using any electrical equipment, observe some fundamental rules:

- Do not touch the equipment with damp or humid hands or feet.
  - Do not install or operate the equipment with bare feet.
  - Do not allow small children or incapable persons to use the equipment.
3. If a gate system component malfunctions, turn off the main power before making any attempt to repair it.
  4. Do not attempt to impede the movement of the gate. You may injure yourself as a result.
  5. This equipment may reach high temperatures during operation; therefore, use caution when touching the external housing of the operator.
  6. Learn to use the manual release mechanism according to the procedures found in this installation manual.
  7. Before carrying out any cleaning or maintenance operations, disconnect the equipment from the electrical supply.
  8. To guarantee the efficiency of this equipment, the manufacturer recommends that qualified personnel periodically check and maintain the equipment.

<b>U.L. Class and FAAC Operator Model</b>		<b>Duty Cycle</b>	<b>Typical Use</b>
<b>Class I: Residential Vehicular Gate Operator</b>			
402	750	Limited duty	• Home use
422	760		• Small apartment building, for example, up to 4 units in a building, with limited public access
412	400		
620	640		
885			
<b>Class II: Commercial/General Access Vehicular Gate Operator</b>			
400	640	Continuous duty	• Apartment buildings
620	885		• Very public access
<b>Class III: Industrial/Limited Access Vehicular Gate Operator</b>			
400	640	Continuous duty	• No public access
620			
885			
<b>Class IV: Restricted Access Vehicular Gate Operator</b>			
620	640	Continuous duty	• Prison rated security
885			

## Table of Contents

Important Safety Information .....	2
Technical Data .....	5
Unpacking the Operator .....	5
Installation Instructions .....	6
Mounting the Operator .....	6
Attach the Chain .....	6
Preliminary Limit Adjustment .....	8
Manual Release.....	8
Solenoid Lock Conversion .....	9
Connect the Main Power .....	10
Power Switch and Receptacle.....	10
Connect Accessory Devices .....	10
Plug-in Loop Detectors.....	10
Plug-in Radio Receiver.....	10
Slave Card.....	10
Activation Devices.....	12
Safety Devices .....	12
Stop Devices .....	12
Accessory Power .....	12
LED Indicators.....	13
Programming .....	13
Test the System.....	15
Entrapment Protection .....	15
Encoder .....	15
Audible Alarm .....	15
Final Limit Adjustment.....	15
Optional Equipment.....	16
Slave/Relay Card .....	16
Battery Back Up System.....	17
Battery Back Up Installation .....	17
Maintenance.....	19
The 885 Operator .....	19
The 885 CAT Control Panel .....	19
Troubleshooting.....	19
Limited Warranty.....	21

## Technical Data

Duty Cycle	100% (Continuous)
Max. Gate Opening	35 ft. ( 10.7 m)
Max. Gate Leaf Weight	1800 lbs. (816.5 kg)
Pulling Force	Programmable
Gate Speed	1 ft./ sec
Partial Opening Distance	Programmable (.5 m increments)
Electric Motor	1 hp / 1200 rpm
Voltage Required	115 VAC, $\pm 10\%$ , 60 Hz.
Amp Draw (Max.)	11 A
Operator Dimensions	18in. (45.7cm) W x 16in. (40.6cm) D x 23in. (58.4cm) H
Operator Weight	129.4 lbs. (58.7 kg)
Operating Temperature	-4° F to 131° F (-20° C to 55° C)

## Unpacking the Operator

When you receive your 885 Operator, inspect the shipping box for physical damage. Then inspect the operator once you have removed it from the box. Notify the carrier immediately if you note any damage because the carrier must witness the damage before you can file a claim.

As you unpack the box, insure that all the following parts are included (also see figure 1).

- 1 each- 885 operator with top cover and housing
- 1 each- Idler Mounting Plate
- 2 each- Idler Sprocket
- 8 each- 10mm Hex Head Bolts
- 8 each- 10mm Lock Washers
- 2 each- 10mm Flat Washers

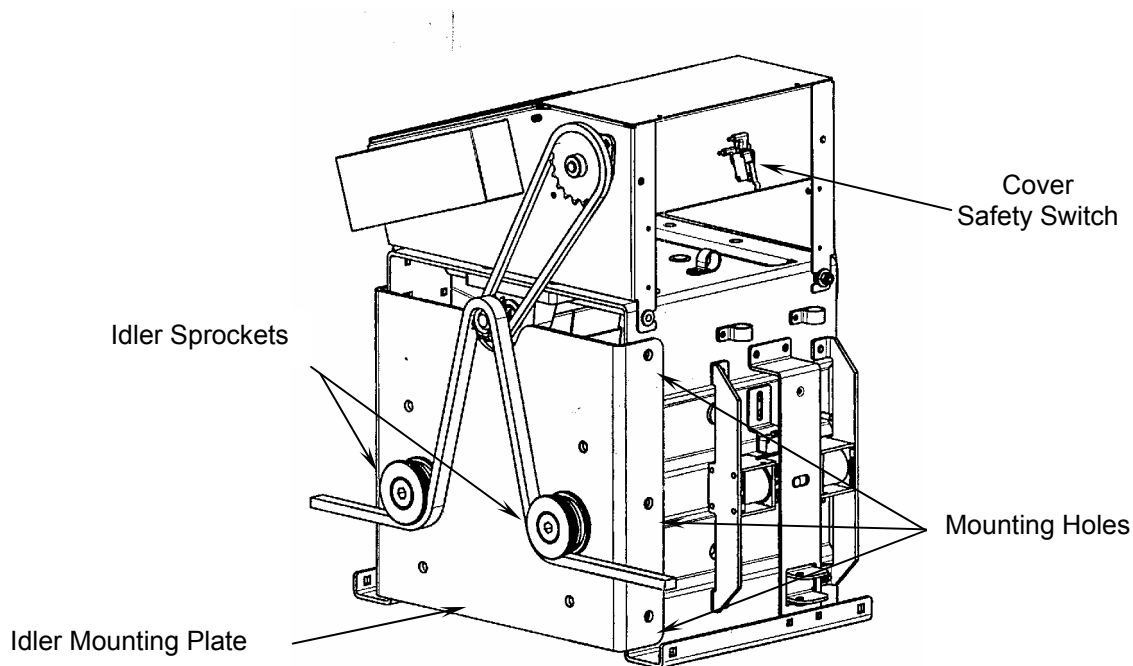

**Figure 1. 885 Operator with top and bottom covers removed.**

# Installation Instructions

**Note:** The following installation instructions assume you are fully capable of installing a gate operator. This manual does not instruct you in designing a gate, installing a gate, or basic electrical wiring. The installation tasks discussed in this manual are tasks particular to the 885 Operator.

Before you install the 885 Operator, make sure that the gate rolls smoothly, without binding throughout its entire travel. Lubricate, adjust, or replace any gate parts or rollers to achieve this.

**WARNING!** A gate that does not roll smooth at start up or anywhere in its travel is a potential safety hazard. The entrapment protection feature of the 885 can only work properly if the pulling force needed to move the gate is consistent throughout the entire travel.

## Mounting the Operator

Before the 885 Operator can be mounted, you must have a footing that is at least 16" x 24" and at least 18" deep. If you are in an area with a frost line to consider, be sure that you get below it. Figure 2 shows an example of a footing that is flush with the edge of the driveway. The footing could be placed further away from the driveway if necessary for your installation.

Before pouring the footing, you must terminate the electrical conduit for main power and any accessories in the proper location. Figure 2 shows an area (within the dashed line, inside the operator) where the conduit can be stubbed up. If you are able to be more precise, the shaded areas show the ideal locations for high voltage (main power) and low voltage (accessory devices) conduit.

Once the footing has been poured, and had a reasonable amount of time to set up, the operator can be set in place. Adjust the operator so that it sits the right distance from the gate, considering the chain mounting brackets that will be used. The center of the main sprocket and idlers of the operator should be in line with the chain mounting holes (or slots) of the chain mounting brackets. As shown in figure 2, if you are using the brackets provided by FAAC, this will place the center of the drive gears anywhere from 1 1/4" to 2 1/2" from the face of the gate.

Once the operator is in place, mark the concrete through the mounting holes of the operator. Remove the operator and use a 1/2" masonry bit to drill holes the appropriate depth for your concrete anchors. Use 1/2" concrete anchors that are at least 3" long. Once the holes are drilled and blown out, pound the anchors in to place.

Set the operator back in place and adjust the distance from the center of the sprocket to the gate face, if necessary. Install the nuts and washers on to the anchors and tighten.

## Attach the Chain

**CAUTION!** Attach the chain with the gate at its midpoint (half open). The 885 Operator is sent to you with the limit adjustments set at the center position. Failure to attach the chain with the gate half open can seriously damage the limit assembly.

If you have a round gate frame (chain link), and plan to use the chain mounting kit provided with the operator, attach the "L" shaped plates to the gate as shown in Figure 2. Use the "U" bolts (muffler clamps) to attach them so that the slot for mounting the chain is at the same height as the bottom of the idler sprockets.

If you are using another bracket or have something prefabricated to the gate, be sure that the hole for the chain mounting tension bolt is close to the same height as the bottom of the idler sprockets. If necessary, the idlers can be mounted in one of three positions to accommodate a height difference.

Assemble the 10' chain sections with the master links that are provided. If necessary, use a chain break to cut the chain to the appropriate size. Attach the chain tension bolts to either end of the chain with the master links. Screw one of the nuts and slide one lock washer on to each tension bolt before putting it through the hole (or slot) in the chain-mounting bracket. Screw the second nut on to the tension bolt after it is installed in the mounting bracket. Use the second (outer) nut to adjust the chain tension and then lock down the adjustment with the inner nut and lock washer.

Mount the chain to the gate on one end; then run it under the first idler, over the main sprocket, and under the other idler. See Figure 1. Then mount the chain to the gate on the other end.

To properly adjust the chain mounting and tension, you must first roll the gate opened and closed to insure proper alignment.

**WARNING!** Moving the gate manually before making a preliminary limit adjustment, can seriously damage the limit assembly. Please see the next section before finalizing your chain mounting.

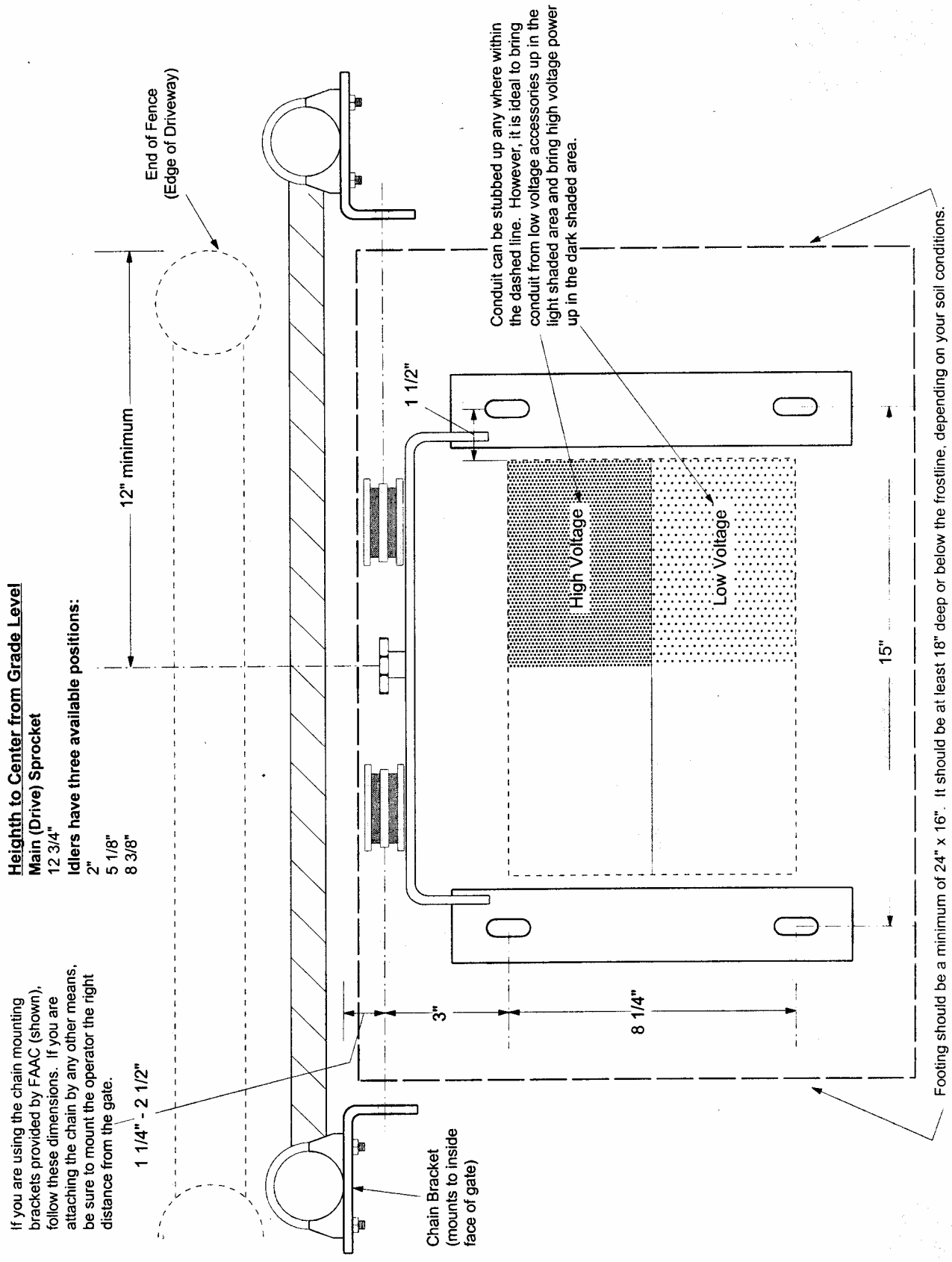

Figure 2. The footprint of the 885 Operator, top view

## Preliminary Limit Adjustment

Before moving the gate manually with the chain attached, you must back the limit adjusters off (spin them toward the center of the adjusting rod)(See Figure 3). Doing so will insure that you will not bottom them out on the end of the threaded rod as you move the gate. To do this, lift the wire retainer while spinning the adjuster.

Once the limits are backed off, you can move the gate by hand, watching to make sure that the limit adjusters do not reach the end of the threaded rod as you move open and closed.

Because the main power has not yet been applied, you should be able to move the gate by hand. Roll the gate to the full open and closed positions and make any adjustments to the chain mounting that are necessary.

Once the chain is properly aligned, move the gate to the open position and then the closed position to perform a preliminary limit adjustment. As you move the gate open, notice that the limit adjusters are moving toward one of the limit switches. This is your open limit switch. Lift the wire retainer and spin the closest limit adjuster toward the open limit switch. Temporarily set it so that it engages the switch before the gate is all the way open (6"-12" short of the open position). Be sure that it triggers the switch early by slowly moving the gate by hand.

Repeat this procedure in the closed position by setting the closed limit 6"-12" short as well to be sure that the gate does not travel too far once power is applied.

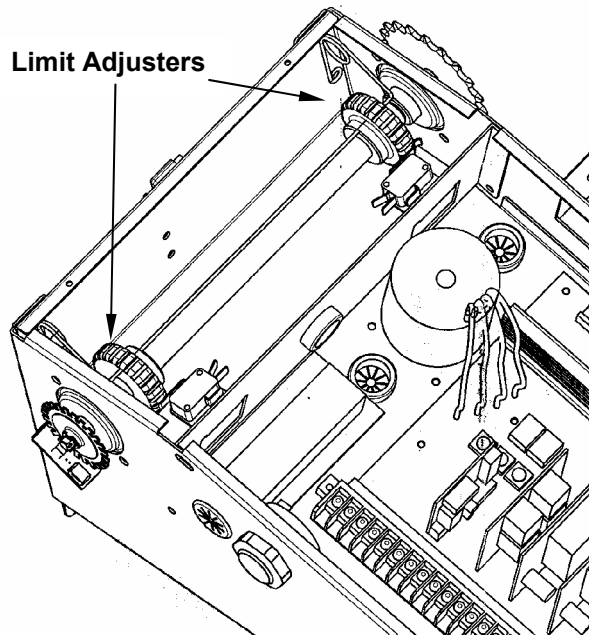

**Figure 3. The 885 Limit Assemblies**

## Manual Release

The 885 Operator features a lockable, manual slide lever that allows you to unlock the gate at any time. As indicated by the label on the operator cover, the gate is engaged when the lever is down and disengaged when the lever is up.

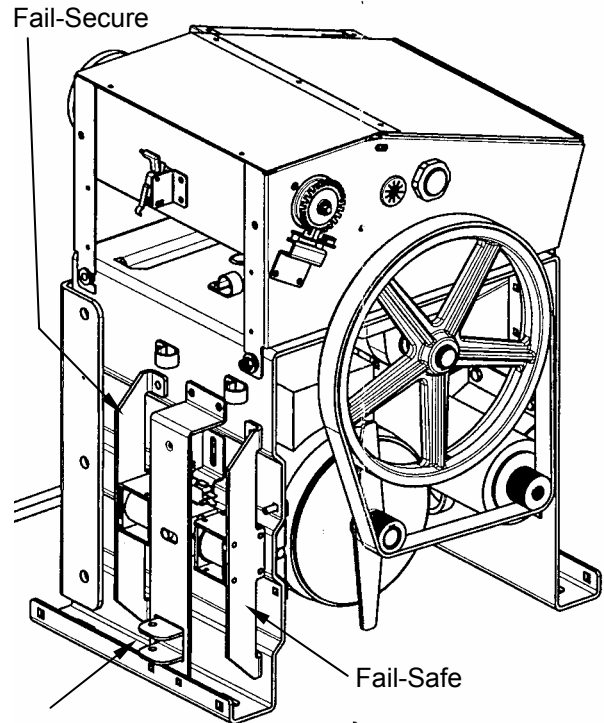
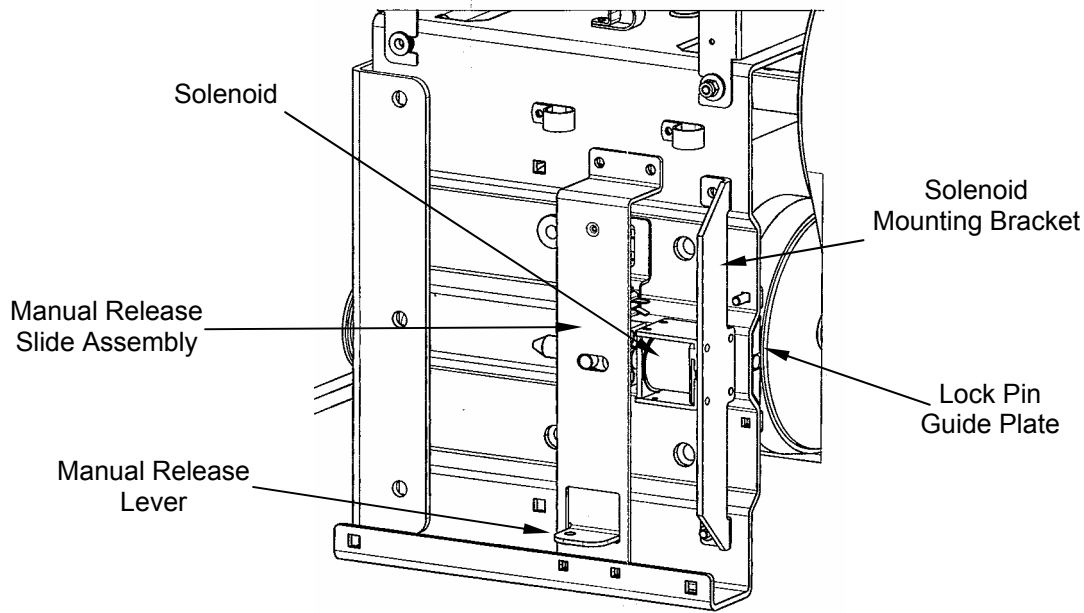

**Figure 4. The 885 Operator's Manual Release Lever and Lock Solenoid (shown in fail-safe and fail-secure positions)**

The control panel of the 885 operator features a selection when programming, that allows you to choose whether the gate will be locked or not in the event of a power failure. The SO (solenoid, discussed on page 14) function of the operator gives you two choices:

- Y      Fail-safe mode: Gate can be moved manually when power fails.
- n      Fail-secure mode: In the event of a power failure, you must use the manual release mechanism for manual operation of the gate.

In addition to the programming choice, the solenoid itself must be mounted in the proper position for the operator to function correctly. The solenoid is installed at the factory in the fail-safe position (shown in figures 4 & 5). This is the factory recommended position if you are not using the optional battery backup system (see *Optional Equipment* on page 15). Unless you re-mount the solenoid in the fail-secure position you must choose Y (fail-safe) on the SO function setting.



**Figure 5. The Manual Release Lever and Lock Solenoid (shown in the fail-safe position)**

The fail-secure setting is handy in more secure applications. However, it requires the user to manually slide the lever to disengage the gate. Because the manual release lever can be locked (with a padlock, not included), it may even require the use of a key to disengage the gate. If your application requires the use of the fail-secure setting, you will need to follow the procedure for remounting the solenoid lock.

## Solenoid Lock Conversion

**WARNING!** Turn off the main power before making any electrical connections or attempting to perform this conversion.

To convert the solenoid from fail-safe to fail-secure, you will need a 10mm socket, a small flat blade screwdriver, and a small pair of external snap ring pliers. Then, refer to figures 4 and 5, and follow the steps below:

1. Disconnect the two red solenoid wires at the junction above the solenoid assembly.
2. Remove the solenoid mounting bracket by removing the two bolts (one on top, one on bottom) and sliding the assembly to the right.
3. Note the position of the solenoid return springs (above and below the solenoid pin) and remove them for safekeeping.
4. Remove the two clip-in nuts that were used to mount the solenoid bracket and install them in the new bracket location (two square holes on the other side of the manual release slide assembly).
5. Remove the manual release slide assembly (4 bolts) to gain access to the solenoid pin assembly.
6. Remove the lock pin guide plate (2 carriage bolts with self-locking nuts).
7. Remove the solenoid pin assembly (nylon slide block with solenoid pin and lock pin) being careful not to damage the solenoid switch.
8. Next, remove one snap ring from the lock pin, slide the pin out, re-insert the pin in the other side so that it extends the opposite direction, and re-install the snap ring.
9. Follow steps 7-5 in reverse.
10. Follow steps 3-1 in reverse, keeping in mind that during step 2, the solenoid mounting bracket will be installed in the new location on the left side of the manual release slide assembly.

The final step will be to set the SO function to n for fail secure when you get to the programming stage.

## Connect the Main Power

**WARNING!** Turn off the main power before you make any electrical connections.

The installer is responsible for providing a dedicated 20 Amp circuit breaker and for making sure that all electrical wiring and connections conform to all applicable electrical codes.

By now, the conduit from your power source should be stubbed up beneath the operator as discussed earlier in the operator mounting section and shown in Figure 2.

The 885 Operator requires 115 VAC. The 115 volt power should run through the 2" knockout on the right side of the operator and be terminated in the junction box (single gang handy box) mounted slightly above the knockout, see Figure 6. Remove the blank cover and run the power wires in through the open fitting on the left side of the box. Connect the 115-volt line to the black wire (or the black wire labeled "1"). Connect the neutral to the white wire (or the black wire labeled "2"). Connect the ground wire to the yellow wire with the green stripe. Reinstall the cover on the junction box.

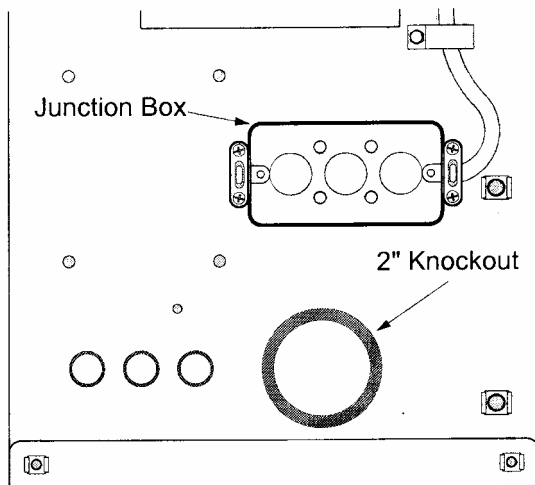

**Figure 6. The right side of the 885 Operator**

## Power Switch and Receptacle

On the top of the 885 Operator (next to the control panel) there is a main power disconnect switch and a 115-volt receptacle. The switch controls power to the entire operator, including the receptacle. The receptacle provides power for keypads, telephone entry systems, and other devices that require the use of a plug-in transformer.

## Connect Accessory Devices

**WARNING!** Turn off the main power before you make any electrical connections.

### Plug-in Loop Detectors

The 885 CAT provides terminals for plug-in Free Exit and Safety loop detectors. When plugging the detectors in, be sure that the component side of the detector faces the display on the 885 CAT. If the installation does not require the use of one or both detectors, simply leave the appropriate terminal empty.

The terminal labeled "EXIT LOOP" or "J1" accepts a detector to serve as a free exit. Plug the detector in and connect the loop leads to terminals 11 and 12. If you are using more than one exit loop, connect the loops in series across terminals 11 and 12. See Figures 7 and 8.

The terminal labeled "SAFETY LOOP" or "J2" accepts a detector to serve as a safety. Plug the detector in and connect the loop leads to terminals 9 and 10. If you are using more than one safety loop, connect the loops in series across terminals 9 and 10. See Figures 7 and 8. To activate the Safety Loop Detector you must install a jumper across terminals 7 and 8, and enable Safety 2 by choosing Y on the S2 function of the programming. See the *Programming* section on page 13.

For more detailed instructions on the loop detectors, consult the Diablo Controls instruction sheet included with your operator.

### Plug-in Radio Receiver

The 885 CAT provides a terminal for the FAAC plug-in radio receiver. Simply match the DIPswitches on the receiver with those on the transmitters and plug it in to the terminal labeled "DECODER" or "J6". The receiver can only be plugged in one way.

### Slave Card

There is an optional card that enables you to run two operators in a master/slave configuration. It also has six relays to give you contact closures at different positions. See the *Optional Equipment* section on page 16.

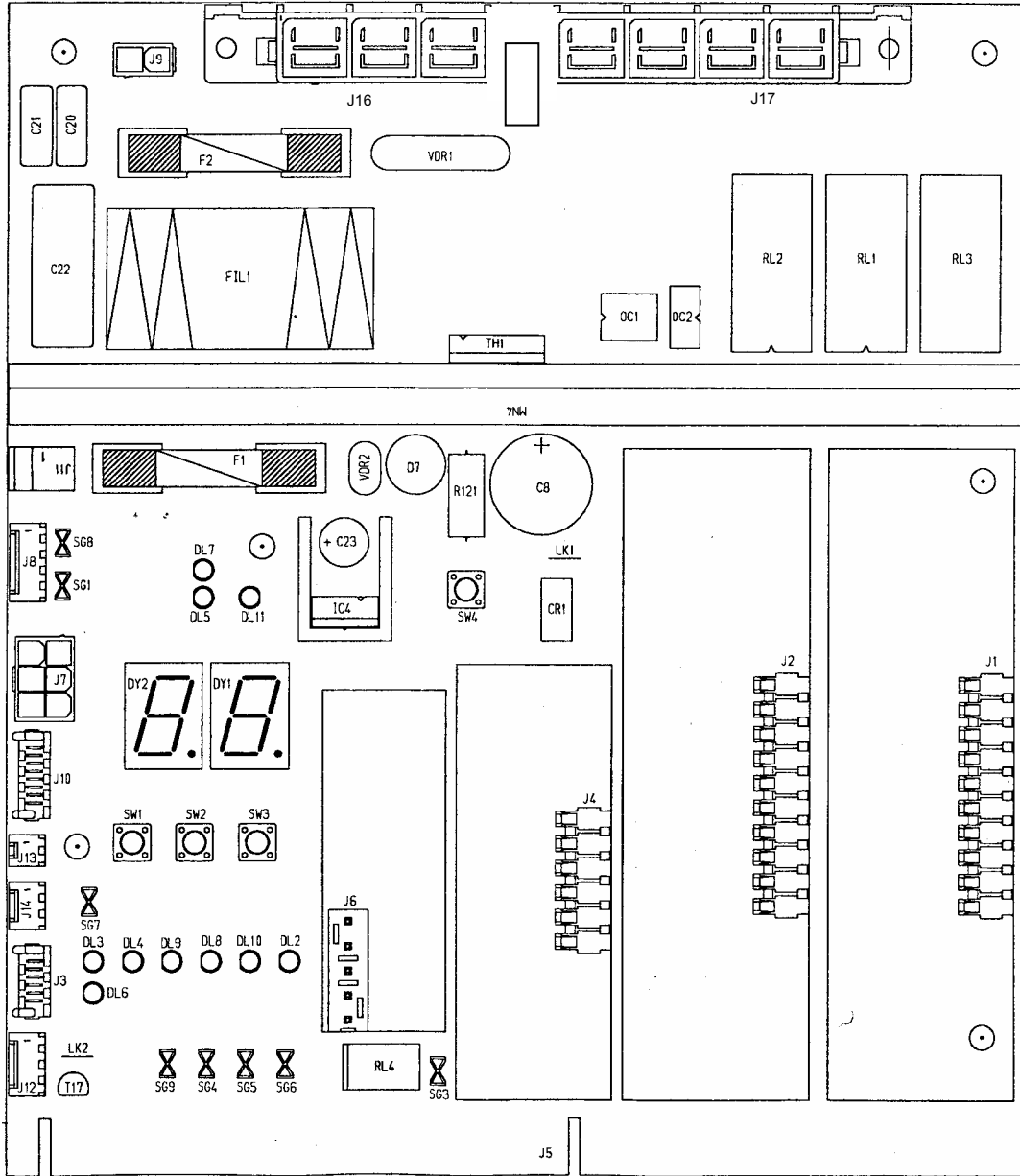

**Connectors**

- J1- Exit Loop
- J2- Safety Loop
- J3- Encoder
- J4- Slave Card/ Gate State
- J5- Main Terminal
- J6- Radio Receiver
- J7- Battery Back Up
- J8- Limit Switches
- J9- Transformer Primary
- J10- Battery Back Up
- J11- Transformer Secondary
- J12- Solenoid Lock
- J13- Cover Stop Switch

- J14- Buzzer/ Alarm

- J16- Main Power
- J17- Motor

**Fuses**

- F1- 1.6A Accessory
- F2- 12.5A Main Power

**Switches/ Buttons**

- SW1- +
- SW2- -
- SW3- F (Function)
- SW4- Reset

**L.E.D.s**

- DL2- Safety 2
- DL3- Open A
- DL4- Open B
- DL5- Open Limit
- DL6- Encoder
- DL7- Close Limit
- DL8- Stop
- DL9- Safety 1
- DL10- Solenoid Lock
- DL11- +5 volts

Figure 7. The 885 CAT control panel layout

## Activation Devices

The activating devices for your gate must have normally open (N.O.) contacts. Connect the normally open (N.O.) to terminal 1 (Open A) and the common (COM) to terminal 5 (Common). Multiple devices should be connected in parallel. The 885 CAT also has a partial open feature in the A and EP modes. If you have a certain activation device that you would like to use to open the gate part way, connect the normally open (N.O.) to terminal 2 (Open B) and the common (COM) to terminal 5 (Common). The distance that the gate opens is determined by the PO (Partial Open) function that is set during the programming phase. See the *Programming* section on page 13.

When using the B or C mode (separate open and close inputs), terminal 1 (Open A) is the normally open input to open the gate. Terminal 2 (Open B) is the normally open input to close the gate.

## Safety Devices

The safety devices for your gate must have normally closed (N.C.) contacts. Connect the normally closed (N.C.) to terminal 3 (Safety 1) and the common (COM) to terminal 5 (Common). Multiple devices should be connected in series.

The way that the 885 responds to a triggered safety device will depend on how the S1 (Safety 1) function of the programming is set. See the *Programming* section on page 13.

**Note:** In order to comply with UL325, you must install two sets of FAAC photobeams, one inside and one outside.

## Stop Devices

The stop devices for your gate must have normally closed (N.C.) contacts. Connect the normally closed (N.C.) to terminal 4 (Stop) and the common (COM) to terminal 5 (Common). Multiple devices should be connected in series.

**Note:** If you are not using a stop or safety device, a circuit must be installed for the control panel to function normally.

## Accessory Power

The 885 CAT control panel provides 24 volt DC to power accessory devices. There are three positive outputs (terminals 13, 14, & 15) and three negative outputs (terminals 16, 17, & 18). Maximum accessory load is 1.6 amps.

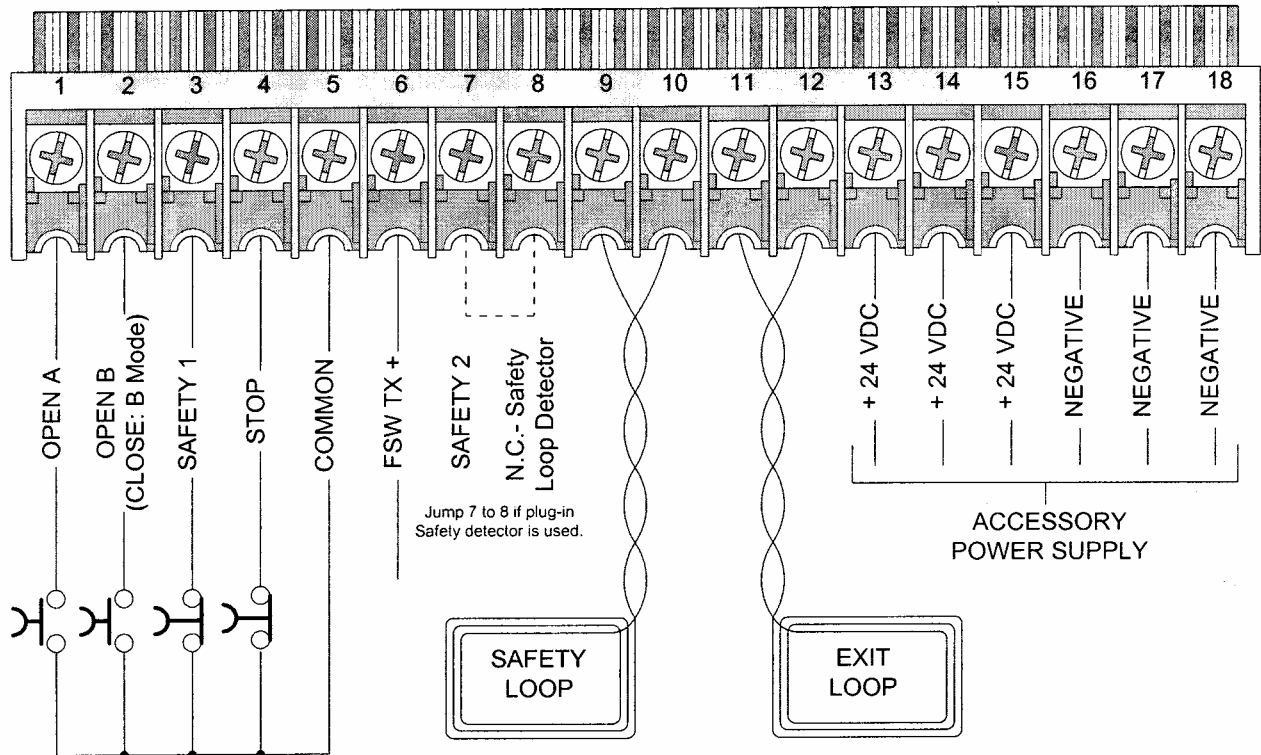

Figure 8. The terminal strip of the 885 Operator

## LED Indicators

The 885 CAT has ten light emitting diodes that show you what signals it is being given from the input devices (open devices, safety devices, limit switches, etc.). The following table shows the function of each LED.

<b>DL2</b>	<u>Safety 2</u>	Should be <b>on</b> unless the safety circuit is triggered.
<b>DL3</b>	<u>Open A</u>	Should be <b>off</b> unless an activation signal is being sent.
<b>DL4</b>	<u>Open B</u>	Should be <b>off</b> unless a partial open signal (close signal in B or C mode) is being sent.
<b>DL5*</b>	<u>Open Limit</u>	Should be <b>on</b> unless the gate is open.
<b>DL6</b>	<u>Encoder</u>	Comes <b>on</b> each time the optical reader reads a tooth on the encoder.
<b>DL7*</b>	<u>Close Limit</u>	Should be <b>on</b> unless the gate is closed.
<b>DL8</b>	<u>Stop</u>	Should be <b>on</b> unless a stop signal is being sent.
<b>DL9</b>	<u>Safety 1</u>	Should be <b>on</b> unless a safety signal is being sent.
<b>DL10</b>	<u>Solenoid Lock</u>	Shows position of solenoid. Depends on fail-safe or fail-secure mounting.
<b>DL11</b>	<u>+5 volts</u>	Should be <b>on</b> unless microprocessor is receiving inadequate voltage.

\* If gate opens to the right DL5 is now the close led and DL7 is now the open led.

## Programming

Programming the 885 is accomplished by using the +, -, and F buttons located near the display on the control panel. Each time the F button is pressed and held, the next function is displayed. Each time the F button is released, the value for that function is displayed and can be modified with the + and - buttons. As you toggle the F button through the programming functions, follow the list below for a detailed description of each function.

**St**

**Status** (the operator status is displayed)  
During operation, a number displays the current status.

00	Closed
01	Opening
02	Stopped (no limit triggered)
03	Open
04	Pause
05	Fail- safe Test
06	Closing
07	Battery On

Be sure to leave the Status function displayed after any programming changes.

**Pl**

**Pause time** (selects the pause time before automatic close from 0 seconds to 4 minutes) “A” logic only.

Time is adjusted in one-second increments from 0 to 60 seconds. After 60 seconds is reached, time is adjusted in one-minute increments up to 4 minutes.

**F0**

**Force** (selects the motor torque at full speed)  
Torque is adjusted from 0 (minimum) to 9 (maximum). The operator starts moving at the maximum force for approximately 0.8 seconds. The torque is then reduced to the programmed value.

**Note:** It is best to start with a force setting of 4 or 5, then adjust it appropriately for the entrapment protection to work properly.

**WARNING!** To comply with UL325, the gate must stop and reverse if it encounters a force of 40 lbs. or more. Be sure that force setting is adjusted appropriately.

**EO**

**Time Out** (selects the maximum motor run time from 0 to 100 seconds)

Time is adjusted in one-second increments from 0 to 60 seconds. After 60 seconds is reached, time is adjusted in 10-second increments up to 1 minute, 40 seconds.

Time out can be calculated by figuring the time it takes for the gate to run open or close and adding 10%. Either count the time (in seconds) it takes to open, or do the math (based on a 1ft./sec speed) to figure the full travel run time. Then use this formula to figure your time out setting:

Full travel run time (sec.) x 1.1 = Time out

**LO**

**Logic** (selects the operating logic)

There are four operating logics available on the 885 CAT:

- A** Automatic mode- Gate opens with an activation signal, stays open for the programmed pause time, and closes automatically.
- EP** Semi-automatic mode- Gate opens with an activation signal and remains there until another activation signal is sent, at which time, it closes.
- B** Guard (manned) mode- Separate open and close inputs. Use this logic with a 3-button station.
- C** Constant Pressure mode- Separate open and close inputs. In this mode you must maintain the signal throughout the travel or the gate will stop.

**d1** **Direction** (selects the opening direction)  
The display for this function shows an arrow that should point toward the open position.



Choose the appropriate direction for your installation.

**AO** **Automatic Open** (with battery backup only)  
Use this feature if you have installed the optional dc motor, batteries, and battery backup control unit. Choices are:

- Y** Gate automatically opens when power fails.
- n** When power fails, gate remains closed until open input is given.

Be sure to choose **n** if you are not using the optional battery backup.

**AC** **Automatic Close**  
This feature is also for use with or without the optional battery backup. Choices are:

- Y** Gate automatically closes when AC power returns.
- n** When AC power returns, the gate remains open until an input is given.

Be sure to choose **n** if you are not using the optional battery backup.

**SO** **Solenoid** (selects the operation of the manual release solenoid)

- Y** Fail-safe mode: Gate can be moved manually when power fails.
- n** Fail-secure mode: In the event of a power failure, you must use the manual release mechanism for manual operation of the gate.

The manual release solenoid must be mounted properly for your selection (see the Manual Release section on page 8). The 885 Operator comes with the solenoid mounted for fail-safe mode.

**AL** **Alone** (This is a new function that is not yet incorporated in the software of the 885 CAT.)

- Y** Be sure to choose this setting.
- n** Do not use. Will cause the control panel not to function.

**SL** **Slave** (selects master or slave operator in a master/ slave configuration)

- Y** slave operator
- n** master operator

If you chose **Y** on the previous function (stand-alone), be sure to choose **n** (master) now.

**FS** **Fail-safe test** (photo beam operational test)  
This is a European safety test that tests the photobeams before every cycle. In the U.S. it is typically left disabled.

- Y** enabled
- n** disabled

**S1** **Safety 1** (selects the function of the safety 1 input on terminal 3)

**OC** Opening: Gate stops when safety device is triggered and closes when safety device is cleared.

Closing: Gate stops when safety device is triggered and opens when safety device is cleared.

**CL** Opening: No effect

Closing: Gate re-opens when safety device is triggered.

**PO** **Partial opening** (Open B input at terminal 2)  
Selects the distance of the partial opening from 0.5 meters to 5 meters in 0.5 meter increments.

Leaving the setting at 0 disables the partial opening feature. 1 meter = 39 inches.

**S2** **Safety 2** (Use this function to enable or disable the plug-in safety loop detector).

- Y** safety 2 (plug-in detector) is used
- n** safety 2 (plug-in detector) is not used.

If you are using the plug-in safety loop detector, be sure to jump terminal 7 to 8 as well.

**FL** **Safety 2** (device selection)  
This is a new function that is not yet incorporated in the software of the 885 CAT.

Be sure to choose the **L** setting.

**F** Do not use. Will cause the control panel not to function.

**L** Be sure to choose this setting.



**Safety 2** (selects how the plug-in safety loop detector will affect the gate's operation)

- OP** Opening: Gate stops when safety device is triggered and closes when safety device is cleared.  
Closing: No effect
- CL** Opening: No effect  
Closing: Gate re-opens when safety device is triggered.
- OC** Opening: Gate stops when safety device is triggered and closes when safety device is cleared.  
Closing: Gate stops when safety device is triggered and opens when safety device is cleared.

After you have made all your programming selections and run the gate at least one full cycle at full speed, you must toggle through each function again to lock them in to the memory. This will also give you an opportunity to double-check the setting of each function. It is best to leave the display showing the St (Status) function so that the status of the gate will always be displayed.

**Note:** If you find the display showing two red dots, this is a power saving mode. The display will return if you push the + or - buttons.

## Test the System

Once you have connected main power, connected the accessory devices, and programmed the 885, you can test the gate system.

**WARNING!** If you have not performed a preliminary limit adjustment (discussed on page 7), do so before testing the operator.

With the gate in the closed position, turn on the main power and check the status of the LED indicators. See *LED Indicators* on page 13. Correct any problems with your input devices if necessary. Once the LEDs are illuminated properly, make sure that the gate path is clear, and give the 885 an activation signal. The gate should run open slowly as it looks for the open limit. If you are in the automatic mode, the gate should time out and close after the programmed pause time. If you are in any other mode, give the operator a close signal. The gate should run closed slowly as it looks for the closed limit.

The initial cycle is a learning mode in which the gate will run slow as it searches for the limit switches. Once it is complete, the operator will run at full speed.

Continue to cycle the gate and test all input devices. Be sure that all safety devices are functioning properly.

## Entrapment Protection

The 885 Operator features an entrapment protection system. It incorporates an optical encoder, which monitors the gate's movement, along with an adjustable force output and an audible alarm to warn you when the gate encounters something or someone.

**WARNING!** The entrapment protection system will not function properly if the force setting (see *Programming* on page 13) is not set properly. It must be set strong enough to move the gate consistently, but be able to be stopped if it encounters a force of 40 lbs. or more.

**WARNING!** The entrapment protection system must be adjusted to function properly to comply with UL325.

## Encoder

The encoder is a device that monitors that movement of the gate. It determines when the gate will slow down before triggering a limit and when the gate has encountered an obstruction. If it senses that the gate has stopped moving without a limit being triggered, the gate will invert movement and run slowly the other way.

## Audible Alarm

The 885 features an audible alarm that will sound if the gate encounters two sequential obstructions in the same cycle. For example: The gate is running closed and encounters an obstruction. The encoder senses this and immediately re-opens the gate. If the gate encounters another obstruction before reaching the open limit, the gate will stop and the alarm will sound. The main power must be reset before the operator will be ready for another signal.

## Final Limit Adjustment

Once the system has been tested thoroughly and everything is functioning properly, you will need to fine-tune the limit adjustments. Following the same steps as you did during the preliminary limit adjustment, fine-tune the position of the limit adjusters. See Figure 3. If the gate stops too soon, back the limit adjuster off. If it goes too far, turn it toward the limit switch. Make small adjustments and cycle the gate after each adjustment to check the result.

## Optional Equipment

The following optional items are available for your 885 Operator.

### Slave/Relay Card

The 885 Slave/Relay card is a device that allows you to obtain the following features.

- 1) Slave: Enables two opposing operators to operate simultaneously, preventing any lag time between the gates when a signal is sent to the operators to open.
- 2) Relay: Provides eight normally open (N.O.) contacts for connecting extra equipment, such as lighting controls, counters and so forth.

The slave/relay card plugs into the master 885's control panel (J1).

Plugging the card into the master 885 control panel and then wiring the two boards together as shown in Figure 9 achieves the master/slave configuration.

The slave will then react as the master does.

The following things must be done in the programming stages to insure the proper operation of both the master and slave operators.

- 1) The master unit **must** be installed on the longer leaf.
- 2) Set the **slave** unit time out equal to the time set on the master.
- 3) The safety devices must be connected to the **master** unit.
- 4) Program the following function on the **master** operator.

"Stand Alone"	AL	Y
"Slave"	SL	N

- 5) Program the following function on the **slave** operator.

"Stand Alone"	AL	Y
"Slave"	SL	Y

- 6) If you are in "A" mode and have a jumper placed between terminals two and five than set your slave machines pause time to 00 Seconds.

**Note:** The slave unit provides, to the master, the following information.

Limit switch activation: During opening or closing movements, the master unit waits for the slave to end its cycle. (Limit switch engaged).

Entrapment device activation: When the slave unit detects an entrapment, the movement reverses both operators.

Each terminal on the card along with the common terminal (labeled -) provides a contact with a maximum rating of 1 amp for a 30VDC accessory, each contact closes under a certain condition of the gate leaf. Use the following chart to achieve the desired activation.

Pin 1	Gate closed
Pin 2	Opening
Pin 3	Open (No limit switch engaged)
Pin 4	Opened
Pin 5	Pause Time
Pin 6	Fail Safe
Pin 7	Closing
Pin 8	Power failure and gate stopped (Battery Use)
Pin -	Contact Common

### Slave Terminal Strip

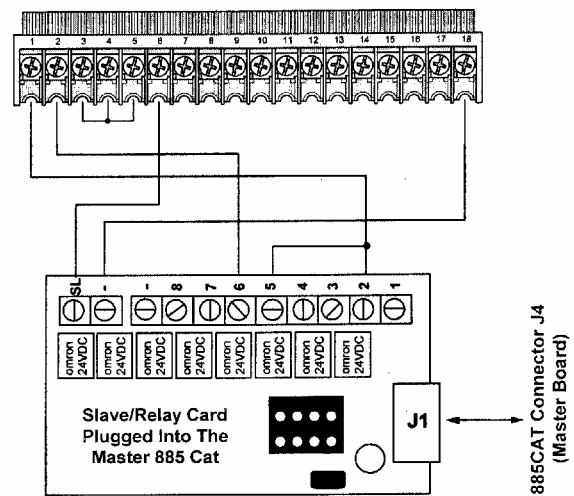

**Figure 9. Slave Card Wiring**

**Note:** Apply the jumper wire between terminals two and five when using "A" mode only.

## Battery Back Up System

When installed, this system will provide battery power in the event of a loss of AC power. How it will function depends on two things:

1. Which logic you are running in (A, EP, or C).
2. If you choose “Y” or “n” for the AO (Automatic Open) function in the programming of the 885CAT control panel.

If you are running in A or EP mode it will function as follows:

**Automatic Open enabled** (select Y for the AO function of the programming)

When AC power fails, the battery back up instantly sends power to the control panel. The gate opens after a short delay and remains open. Once power returns, one of two things will happen, depending on whether you have the AC (Automatic Close) function enabled or disabled. If you have chosen “Y” for the AC function, the gate will close automatically. If you have chosen “n” for the AC function, the gate will remain open, but be ready for a close signal.

**Automatic Open disabled** (select “n” for the AO function of the programming)

When AC power fails, the battery back up instantly sends power to the control panel and it is ready for an open signal. If a signal is not received right away, the panel “sleeps” until a signal is received. A signal will wake the system up and open the gate. In this mode (Automatic Open disabled), you can continue to open and close the gate as long as the batteries are charged. Whether you are running in A or EP logic under normal power makes no difference. When running on battery power, the gate will operate in EP mode. The number of cycles that you can run with fully charged batteries will depend on the length of your gate.

If you are running in C mode it will function as follows:

Whether you have the Automatic Open (AO) function enabled or disabled makes no difference. When AC power fails, the gate will not automatically open. The battery back up instantly sends power to the control panel and it is ready for an open signal. You can open the gate one time and then the back up will shut down until AC power is restored.

When running on battery power the photobeams will function normally in any logic. The inherent entrapment will function, although slightly different than under normal AC power. If the gate is obstructed while running under battery power, it will stop and the alarm will sound. Another open signal will silence the alarm and the gate will continue in the same direction.

## Battery Back Up Installation

**WARNING!** Turn the main power to the operator off before performing any of the tasks involved in installing the battery back up system. This installation should be performed by qualified personnel only. When you open the battery back up system, the box should contain the following:

- 1- DC Motor
- 1- Battery back up control panel
- 2- 12-volt batteries
- 1- Cross brace for operator chassis
- 1- Battery tray
- 1- Set of battery wires
- 1- 6-wire interface cable
- 1- 8-wire ribbon cable
- 1- Drive belt
- 4- M6 x 20mm carriage bolts
- 8- M6 flat washers
- 8- M6 self-locking nuts
- 1- Pulley
- 1- M4 x 12mm bolt
- 1- M4 fender washer
- 1- Feather key
- 2- 16mm wire chase nipples
- 4- Snap-in standoffs
- 2- M8 x 20mm hex bolts
- 2- M8 self-locking nuts

The tools needed for installing the battery back up system are as follows:

- 3mm Allen wrench
- Small flat blade screwdriver
- 10 mm Socket
- 13 mm socket
- 13 mm open end wrench

To install the battery back up system, follow the steps below and refer to figures 10 and 11.

1. If you haven’t done so already, turn off the main power.
2. Remove the existing drive belt.
3. Mount the DC motor in the location shown in figure 11. Secure it with 4 each of the 6mm flat washers and self-locking nuts.
4. Run the DC motor wires through the wire chase directly above the DC motor. If there is not a plastic nipple already installed in the hole, insert one of the 16mm chase nipples that was provided with the system. Reach in the left side of the operator, under the control panel tray to grab the wires and feed them up into the control panel area.

5. Insert the battery tray in the large square hole on the right side of the operator. The round holes on the two straps that extend upward from the tray will line up with the square holes on the operator. Install the 4 carriage bolts from the inside out and secure with the remaining flat washers and self-locking nuts.
6. Install the feather key into the key way of the dc motor's output shaft. Slide the pulley on and secure with the 4mm fender washer and bolt.
7. Install the new (longer) drive belt. Put the drive belt behind the main pulley for ease of installation.
8. Once the drive belt is installed, mount the cross brace across the bottom of the operator (mounting points shown in Figure 11) with the 8mm hex bolts and self-locking nuts.
9. Run the two battery wires up through the empty wire chase above the battery tray. If there is not a plastic nipple already installed in the hole, insert one of the 16mm chase nipples that was provided with the system. Reach in the left side of the operator, under the control panel tray to grab the wires and feed them up into the control panel area. Leave enough slack for the four connectors to be plugged into the batteries before the batteries have been slid into the tray. Do not install the batteries yet.
10. Reach in the left side of the operator, under the control panel tray and install the four snap-in standoffs for the battery back up control panel. Snap them in from the bottom up in the holes provided next to terminal 1 of the 885 CAT.
11. Install the battery back up control panel so that the four wiring terminals face the gate leaf.
12. Connect the battery and motor wires as shown in figure 10.
13. Plug the 8-wire ribbon cable into J10 on the battery back up panel and J10 on the 885 CAT.
14. Plug the 6-wire interface cable into J7 on the battery back up panel and J7 on the 885 CAT.
15. Turn AC power back on.
16. Plug the batteries in; red to positive, black to negative. The jumper should connect the negative of one battery with the positive of the other (batteries are wired in series because it is a 24 volt system). Slide the batteries into the battery tray.

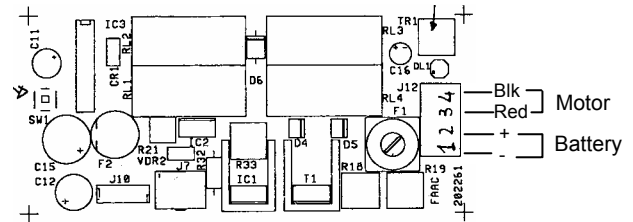

Figure 10. The battery back up control panel

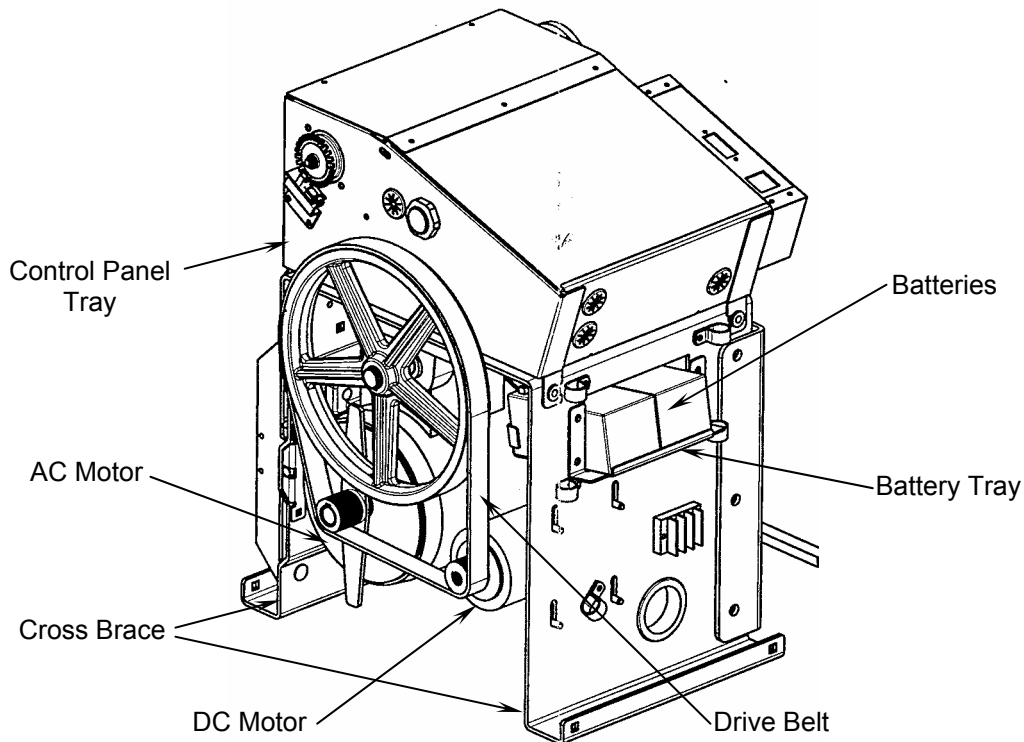

Figure 11. The 885 Operator with the Battery Back Up System installed.

## Maintenance

**WARNING!** Turn the main power to the operator off before performing any maintenance or repairs. The manufacturer recommends that only qualified personnel check and maintain the equipment.

### The 885 Operator

The FAAC recommended maintenance schedule vary according to the frequency of use of the operator, whether lightly used (once or twice an hour) or heavily used (many cycles per hour). Operators used in a humid/salt air climate should follow the heavy use schedule.

#### Lubricate the chain and gate rollers.

Use a light, spray on lubricant (teflon, silicon, WD-40, etc.) to lubricate the entire chain. Grease the gate rollers appropriately for the type of rollers that you have.

**CAUTION!** Do not use heavy grease to lubricate the chain. It will collect dirt and debris, which could damage the chain and/or drive sprockets.

Light duty use: every 6 months

Heavy-duty use: every 3 months

#### Check entrapment protection devices.

Test the photobeams to ensure that the gate responds properly to a potential obstacle. Also check to see if the inherent entrapment protection (reverse on contact) system is functioning properly. The gate should invert movement if it encounters a force of 40 pounds or more.

Light duty use: every 12 months

Heavy-duty use: every 6 months

#### Test the batteries.

If you are using the optional battery back up system, check your batteries to ensure that they are charged.

Light/ Heavy duty use: every 12 months

### The 885 CAT Control Panel

Keep the control panel free from spider webs, insects, etc. Otherwise, the control panel requires no maintenance.

## Troubleshooting

**WARNING!** Turn the main power to the operator off before performing any maintenance or repairs. The manufacturer recommends that only qualified personnel check and maintain the equipment.

**Problem:** *When an activation signal is sent, the open light (DL3) comes on, but the gate does not open.*

#### Possible Solutions:

1. Check to see if the stop light (DL8) is illuminated. If not, check the cover safety switch and all other stop devices.
2. If either safety input (Safety 1 or 2) is programmed to be active in the opening direction, check to see that the Safety 1 light (DL9) and the Safety 2 light (DL2) are illuminated. If they are not, check your safety devices.
3. Check to see that the Lock Solenoid is retracting and triggering its switch when the signal is given. When the switch is triggered it will illuminate the DL10 led.

**Problem:** *Gate opens, but will not close.*

#### Possible Solutions:

1. Check the logic setting in the programming. If in A mode gate should close after selected pause time. In any other mode a close signal is required.
2. If either safety input (Safety 1 or 2) is programmed to be active in the closing direction, check to see that the Safety 1 light (DL9) and the Safety 2 light (DL2) are illuminated. If they are not, check your safety devices.
3. Check to see that the control panel knows that the gate is open. Make sure that the open limit light (DL5) is not illuminated. Make sure that the display shows 03 or 04.

**Problem:** *Gate starts it's travel (open or close) but does not make it all the way.*

#### Possible Solutions:

1. Check to see that a limit isn't being triggered prematurely. Check the limit lights (DL5 and DL7). Check the status display.
2. Check to see that the Safety 1 light (DL9) and the Safety 2 light (DL2) are illuminated. If they are not, check your safety devices.
3. Check to see that the operator is able to pull the gate. Increase the force setting if necessary. Adjust the gate and rollers if necessary.

**Problem:** *When the safety devices are triggered, the gate does not respond, as it should.*

**Possible Solutions:**

1. Check to see that your safety devices are connected properly. Photocells should be connected in series across terminals 3 and 5. Terminals 7 and 8 should be jumped for the plug-in loop detector to work properly.
2. If the plug-in loop detector is the problem, make sure that the S2 function is set to Y.
3. Check to see if you have chosen the proper settings for the S1 and FU functions.

**Problem:** *There are no LEDs illuminated on the control panel.*

**Possible Solutions:**

1. Check for 115 volts at the operator's junction box. If you do not have power there, check the main breaker.
2. Make sure the power switch on the top of the operator is on.
3. Check the F1 and F2 fuses on the control panel with an ohm meter or continuity tester.
4. Make sure that the transformer is connected properly to the control panel at J9 and J11.

When troubleshooting any problem with the 885 Operator, the ability to interpret the LED indicators will assist you more than anything. Using the table on page 13 will help narrow down most problems.

A volt-ohm meter (VOM) or a multimeter is also a big part of troubleshooting. It will give you the ability to check voltage, resistance, continuity, etc.

If you have a problem with the 885 Operator and these general solutions don't solve it, contact your dealer or distributor for assistance. If you need further assistance, FAAC offers the best technical support in the industry and you can reach a technician by calling 800-221-8278 or e-mail us at [faactech@vcn.com](mailto:faactech@vcn.com).

## Limited Warranty

*To the original purchaser only:* FAAC International, Inc., warrants, for twenty-four (24) months from the date of invoice, the gate operator systems and other related systems and equipment manufactured by FAAC S.p.A. and distributed by FAAC International, Inc., to be free from defects in material and workmanship under normal use and service for which it was intended *provided* it has been properly installed and operated. FAAC International, Inc.'s obligations under this warranty shall be limited to the repair or exchange of any part of parts manufactured by FAAC S.p.A. and distributed by FAAC International, Inc. Defective products must be returned to FAAC International, Inc., freight prepaid by purchaser, within the warranty period. Items returned will be repaired or replaced, at FAAC International, Inc.'s option, upon an examination of the product by FAAC International, Inc., which discloses, to the satisfaction of FAAC International, Inc., that the item is defective. FAAC International, Inc. will return the warranted item freight prepaid. The products manufactured by FAAC S.p.A. and distributed by FAAC International, Inc., are not warranted to meet the specific requirements, if any, of safety codes of any particular state, municipality, or other jurisdiction, and neither FAAC S.p.A. or FAAC International, Inc., assume any risk or liability whatsoever resulting from the use thereof, whether used singly or in combination with other machines or apparatus.

Any products and parts not manufactured by FAAC S.p.A. and distributed by FAAC International, Inc., will carry only the warranty, if any, of the manufacturer. This warranty shall not apply to any products or parts thereof which have been repaired or altered, without FAAC International, Inc.'s written consent, outside of FAAC International, Inc.'s workshop, or altered in any way so as, in the judgment of FAAC International, Inc., to affect adversely the stability or reliability of the product(s) or has been subject to misuse, negligence, or accident, or has not been operated in accordance with FAAC International, Inc.'s or FAAC S.p.A.'s instructions or has been operated under conditions more severe than, or otherwise exceeding, those set forth in the specifications for such product(s). Neither FAAC S.p.A. or FAAC International, Inc., shall be liable for any loss or damage whatsoever resulting, directly or indirectly, from the use or loss of use of the product(s). Without limiting the foregoing, this exclusion from liability embraces a purchaser's expenses for downtime or for making up downtime, damages for which the purchaser may be liable to other persons, damages to property, and injury to or death of any persons. Neither FAAC S.p.A. or FAAC International, Inc., assumes nor authorizes any person to assume for them any other liability in connection with the sale or use of the products of FAAC S.p.A. or FAAC International, Inc. The warranty hereinabove set forth shall not be deemed to cover maintenance parts, including, but not limited to, hydraulic oil, filters, or the like. No agreement to replace or repair shall constitute an admission by FAAC S.p.A. or FAAC International, Inc., of any legal responsibility to effect such replacement, to make such repair, or otherwise. This limited warranty extends only to wholesale customers who buy directly through FAAC International, Inc.'s normal distribution channels. FAAC International, Inc., does not warrant its products to end consumers. Consumers must inquire from their selling dealer as to the nature and extent of that dealer's warranty, if any.

**This warranty is expressly in lieu of all other warranties expressed or implied including the warranties of merchantability and fitness for use. This warranty shall not apply to products or any part thereof which have been subject to accident, negligence, alteration, abuse, or misuse or if damage was due to improper installation or use of improper power source, or if damage was caused by fire, flood, lightning, electrical power surge, explosion, wind storm, hail, aircraft or vehicles, vandalism, riot or civil commotion, or acts of God.**

FAAC International, Inc.  
303 Lexington Avenue  
Cheyenne, WY 82007

[www.faacusa.com](http://www.faacusa.com)