

**INSTALLATION INSTRUCTIONS
FOR THE
AutoKey SYSTEM**

Sentexsystems

IMPORTANT NOTICE

The AutoKey system is a very reliable and easy to use system. However, damage could occur if it is installed incorrectly. In particular, ***it is critical that the AutoKey system is grounded properly.*** The AutoKey system contains static sensitive components that can be damaged if the system is subjected to static discharge and is not properly grounded. Incorrect installation also invalidates the system's warranty. Therefore, we ask that you take the time to read these instructions very carefully before attempting to install the system.

TABLE OF CONTENTS

This document is divided into seven (7) sections as follows:

<u>SECTION NAME</u>	<u>PAGE</u>
1. Basic Installation Hints and Rules	2
2. Pulling Cables	3
3. Mounting the Cabinet	3
4. Making Basic Connections	4
5. Installing Additional Features	5
6. Testing the System	7
7. Appendix	8

IMPORTANT: The Sentex Systems warranty on this system is conditioned upon Sentex Systems being paid in full for this equipment. This warranty will not be honored until such payment is received by Sentex Systems.

Copyright © 2000
All Rights Reserved

This document is protected by copyright, and may not be copied or adapted without the prior written consent of Sentex. This document contains information proprietary to Sentex and such information may not be distributed without the prior written consent of Sentex. The software and firmware included in the Sentex AutoKey system as they relate to this documentation are also protected by copyright and contain information proprietary to Sentex.

Sentex Systems
Chatsworth, CA

Visit us at www.sentexsystems.com

1 - BASIC INSTALLATION HINTS AND RULES

PLEASE READ THIS SECTION CAREFULLY BEFORE BEGINNING YOUR INSTALLATION

In the sections that follow, detailed procedures are discussed for each step in installing the AutoKey system. In addition to these specific procedures, there are a number of general hints and rules which will help ensure that your installation is done correctly and efficiently. These are discussed below:

1. **GROUND THE SYSTEM AND YOURSELF THOROUGHLY.** The AutoKey system contains a number of static sensitive components which can be damaged by static discharge during installation or during regular use. This type of damage is not covered under Sentex's warranty. A proper earth ground connected to the system's chassis (at the grounding screw shown in the Appendix) will greatly reduce the chances of damage or improper operation.

To be effective, the ground connection should be made by running 12 awg copper wire to a good ground point within 12 feet of the system. This ground point must be at an electrical panel, at a metallic cold-water pipe that runs into the earth, or at a grounding rod at least 10 feet in length that is driven into the earth. If you cannot meet these requirements, a ground will be of little value. Nonetheless, you should try to discharge any static before handling the circuit boards.
2. **PROVIDE POWER FROM A DEDICATED SOURCE.** If you are powering the system from an AC source, be sure that it is solely dedicated to the AutoKey system. Specifically, the outlet in which you will plug the transformer provided should be wired back to its own circuit breaker. This will prevent two problems: **A)** other equipment cannot introduce spikes, noise, surges, or dips into the power circuit that will affect the AutoKey system, and **B)** the AutoKey's operation will not be affected if any other equipment develops a short circuit across the power line.
3. **DO NOT OVERLOAD THE TERMINAL BLOCKS.** The terminal blocks used in the AutoKey system make field wiring simple, but they do have their limits. The terminal blocks are unpluggable and the pins are soldered into the boards. To connect your wires, remove the "head" from the correct terminal and open the screws. Insert the wire into the correct opening in the front and tighten the screw until the wire is held snugly. A slight tug on the wire will tell you whether or not you have a secure connection. When you have made all connections for a given "head", plug it back into the pins designated for that terminal block.
4. **READ THE MARKINGS CAREFULLY.** The connection points are marked on the boards clearly. Before making any connection, make sure you read the markings and understand what that connection point is made for.

2 - PULLING CABLES

The following cabling must be run to the AutoKey Controller board:

1. **System Power:** A 2 conductor cable from the location of the 120 VAC outlet into which you will plug the 12 VAC, 50 VA transformer supplied by Sentex (or a 12 VDC power supply that you provide). See Table 1 below for wire size and distances:

MAXIMUM DISTANCE	WIRE SIZE	BELDEN WIRE NUMBER (RECOMMENDED)
75 ft.	18 awg	8888
150 ft.	16 awg	19501
250 ft.	14 awg	19502
500 ft.	12 awg	9412

Table 1 - Power Wire Distance

2. **Door/Gate Control:** A 2 conductor 16 to 22 awg cable (recommended cable is Belden #9501 or equivalent) from the door strike, magnetic lock, or gate operator for each of the 3 control relays.
3. **Wiring for additional features** as required. See section 5 for a complete discussion of the cabling required for the AutoKey controller's features.

3 - MOUNTING THE CABINET

1. Determine which of the openings into the box (back or bottom) will be used to run wires into the cabinet. If the wires can be pulled through the wall or pedestal on which the unit is to be mounted, you should use the back opening of the box since it provides better protection against tampering and vandalism. If this cannot be accomplished, run the wire through the 3/4 inch conduit into the bottom opening of the cabinet. Be sure to connect the conduit to the unit securely.
2. Remove the circuit board from the unit by removing the screw in the lower left-hand corner and releasing the board from the plastic stand-offs that hold the other three corners.
3. Carefully remove the knockout plug from the back or bottom (depending on which knockout you are using) of the enclosure.
4. Mount the unit on the wall or pedestal securely. Mounting hardware is provided if you are using Sentex's pedestal mount. Tighten down all four screws/bolts.
5. Pull all your wires into the cabinet (if you are using the bottom opening, attach your conduit securely first) and remount the circuit board(s).
6. Ground the system.

4 - MAKING BASIC CONNECTIONS

There are two steps for installing the basic AutoKey system. These steps are as follows:

1. Connect the wires from your door strike(s) and door strike power supply (or whatever other device you are controlling) to TB1 for relay/gate 1, TB2 for relay/gate 2, and TB3 for relay/gate 3 on the controller board (refer to the Appendix). Which terminals you will use will depend on what type of device you are controlling, as described below:
 - A. **For dry contact closure (most gate operators):** Connect one conductor to the “N.O.” terminal and the other to the “COMMON” terminal.
 - B. **For magnetic locks or normally unlocked strikes:** Connect one conductor from your power supply to the “N.C.” terminal and one conductor from the door strike to the “COMMON” terminal of the same terminal block. Then, connect the remaining conductors from each source off the board (for example, by using a wire nut).

NOTE: In order to prevent voltage spikes generated by magnetic locks or DC powered strikes from being induced into the system, it is strongly recommended that a IN4001 diode is installed across the magnetic lock coil, so that the cathode of the diode (the end with the band) is connected to the positive connection of the coil, and the anode is connected to the negative end of the coil.
 - C. **For normally locked strikes:** Connect one conductor from your strike power supply to the “N.O.” terminal and one conductor from the door strike to the “COMMON” terminal of the same terminal block. Then, connect the remaining conductors from each source by tying them together off the board (for example, by using a wire nut).
2. Connect the system power. You can power the system using AC or DC power. If you are using **AC power**, connect the two conductor cable to TB5 on the controller board and the other end to the transformer provided with the system. Then plug the transformer into a 120 VAC outlet.

CAUTION: An excessive run of wire between the system and the transformer or power supply can result in inadequate voltage being delivered to the system due to line loss (Refer to Table 1 on the previous page for wire sizes and maximum distances). Please also refer to point 2 on page 2 of this document for requirements on the use of a dedicated AC power circuit.

If you are using **DC power**, connect the two conductor cable to TB5 on the controller board and the other end to your power supply. Please refer to Table 1 on the previous page for wire sizes and maximum distances. Then plug the power supply into a 120 VAC outlet.

PLEASE NOTE: The AutoKey will not trickle charge a battery, so DC power must be supplied by an uninterruptible power supply. Also, the AutoKey board does not provide a fuse on the DC input, therefore the installer may want to install a fuse between the DC supply and the system during installation.

5 - INSTALLING ADDITIONAL FEATURES

The AutoKey system has a variety of capabilities which may be hooked up at the time of installation. The features discussed in this section are standard on every system. You and your customer just need to decide whether to use them. The installation procedures for all of these additional features are described below:

PLEASE NOTE: It is critical for proper operation of the system that you use the types of cable and grounding procedures specified. If these specifications are not followed, outside sources of electrical interference (such as nearby power control cables or even nearby radio station broadcast towers) may cause erratic operation or processor resetting/lock-up.

WARNING: Before hooking up any of these features, disconnect power from the unit.

- AUXILIARY OPENING/REQUEST ACCESS DEVICES:** Any device (e.g., Knox box or exit button) that provides contact closure can be hooked up to the following pins on TB4:

PINS IN AREA TB4	RELAY THAT WILL BE ACTIVATED
EXIT1 and COM	RELAY 1
EXIT2 and COM	RELAY 2
EXIT3 and COM	RELAY 3

**Table 2 - Connections For Installing
Auxiliary Opening/Request Access Devices**

Use shielded cable and connect the shield to the chassis ground at the ground screw shown in the Appendix. When a contact closure occurs, the system will activate the appropriate relay for the period of time that the customer programs into the system.

- HOOKING UP A PRINTER:** AutoKey systems are designed to communicate with a standard personal computer printer with a serial interface. The ability to use a printer is a standard feature - you just have to hook it up to either the RS 422 or the RS 232 port. Please refer to the appropriate section below for instructions on how to connect your printer:

CONNECTING A RS 232 SERIAL PRINTER

If you are connecting an Okidata 184 Turbo serial printer purchased from Sentex, the printer can be located up to 50 feet from the AutoKey system. For this installation, you will need a 3 conductor, 18 to 24 awg shielded cable (such as Belden Datalene #9925) and a DB25 connector (if you have purchased your printer from Sentex, a DB25 connector is provided with the printer).

The first step of this installation is to connect the wires that you pulled to the DB25 connector. With the use of a wire nut, splice each of the wires in your 3-conductor cable to a corresponding wire on the connector. Next, connect the open end of the cable to terminal TB7 on the AutoKey system as shown below:

PIN NUMBER ON DB25 CONNECTOR FOR THE PRINTER	TERMINAL ON TB7 OF THE CONTROLLER BOARD
3 ("RECEIVE DATA")	TRANSMIT DATA ("XMIT")
7 ("SIGNAL GROUND")	GROUND ("GND")
2 ("TRANSMIT DATA")	RECEIVE DATA ("RCV")

The shield on the cable should be grounded at the AutoKey's ground screw and these cables should not be part of a larger cable that contains wires used for other purposes.

Make sure your printer is running at the same baud rate as your system (refer to page 6 of the manual titled "USING THE MORE ADVANCED FEATURES OF THE AutoKey SYSTEM" on how to program the system's baud rate). You must also make sure that your printer is set for word protocol of 8 data bits, no parity bits, and 1 stop bit (8-N-1). Consult your printer manual to determine how to set this protocol properly.

CONNECTING A RS 422 SERIAL PRINTER

If you are connecting an Okidata 184 Turbo serial printer purchased from Sentex, the printer can be located up to 50 feet from the AutoKey system. For this installation, you will need a 3 conductor, 18 to 24 awg shielded cable (such as Belden Datalene #9925) and a DB25 connector (if you have purchased your printer from Sentex, a DB25 connector is provided with the printer).

The first step of this installation is to remove the flat, 5-hole connector from the end of the "starter" cable provided by Sentex with the printer (you will not need it for the AutoKey system). Next, with the use of a wire nut splice each of the wires in your 3-conductor cable to a corresponding wire on the connector. Connect the open end of the cable to terminal TB6 on the AutoKey system as shown below:

<u>PIN NUMBER ON DB25 CONNECTOR FOR THE PRINTER</u>	<u>TERMINAL ON TB6 OF THE CONTROLLER BOARD</u>
5	/OUT
6	OUT
7 ("GROUND")	GND

The shield on the cable should be grounded at the AutoKey's ground screw and these cables should not be part of a larger cable that contains wires used for other purposes.

Make sure your printer is running at the same baud rate as your system (refer to page 6 of the manual titled "USING THE MORE ADVANCED FEATURES OF THE AutoKey SYSTEM" on how to program the system's baud rate). You must also make sure that your printer is set for word protocol of 8 data bits, no parity bits, and 1 stop bit (8-N-1). Consult your printer manual to determine how to set this protocol properly.

6 - TESTING AND ADJUSTING THE UNIT

VERIFYING THE DIP SWITCH POSITION

In order for the system to operate properly, it is important that the dip switches in area S1 of the Controller board are in the correct position (refer to the Appendix for location). For normal operation and programming, switch 1 and 2 must be in the OFF position. To display a transmitter number on the seven-segment display, switch 1 must be in the ON position and switch 2 in the OFF position.

TESTING THE POWER LEVEL

It is important that the incoming power level is within the specifications of the system. If the power level is not within these specifications, you may experience problems with your system. To test the incoming power, connect the negative lead of a meter to TP2 (GND) and the positive lead to TP3 (PNRV). Set your voltmeter to read DC voltage on a 0-20V range and then apply power to the unit. Your power reading should be between 11.5 and 16.5 VDC. If your reading is above or below this range, you should make the proper adjustments so that the power level is in this range.

TESTING THE RECEIVER

The best way to test the receiver's operation is to set the system to display incoming transmitter numbers and then press the button on a transmitter. To test the receiver, follow the steps below:

1. On the Controller board, set dip switch 1 to the ON position.
2. If you are trying to test a two-button transmitter, aim the transmitter towards the receiver and press the left button on the transmitter. If the receiver is operating properly, the system will display the transmitter's seven-digit number on the LED display.
3. If you are trying to test a single button transmitter, aim the transmitter towards the receiver and press the button on the transmitter. If the receiver is operating properly, the system will display the transmitter's seven-digit number on the seven-segment display.
4. Once you have finished testing the receiver, set dip switch 1 back to the OFF position.

TESTING THE GATE/DOOR OPERATION

The best way to test the gate/door operation of the AutoKey system is to use the auxiliary open inputs as follows:

1. To test relay 1, either short between the "EXIT1" and "COM" pins of terminal TB4 or, if an exit request device is attached to these same pins, activate the exit request device. If the system is operating properly, the gate/door attached to relay 1 should open.
2. To test relay 2, either short between the "EXIT2" and "COM" pins of terminal TB4 or, if an exit request device is attached to these same pins, activate the exit request device. If the system is operating properly, the gate/door attached to relay 2 should open.
3. To test relay 3, either short between the "EXIT3" and "COM" pins of terminal TB4 or, if an exit request device is attached to these same pins, activate the exit request device. If the system is operating properly, the gate/door attached to relay 3 should open.

AutoKey CONTROLLER BOARD

GUIDE TO CONNECTIONS, ADJUSTMENT, AND INDICATORS

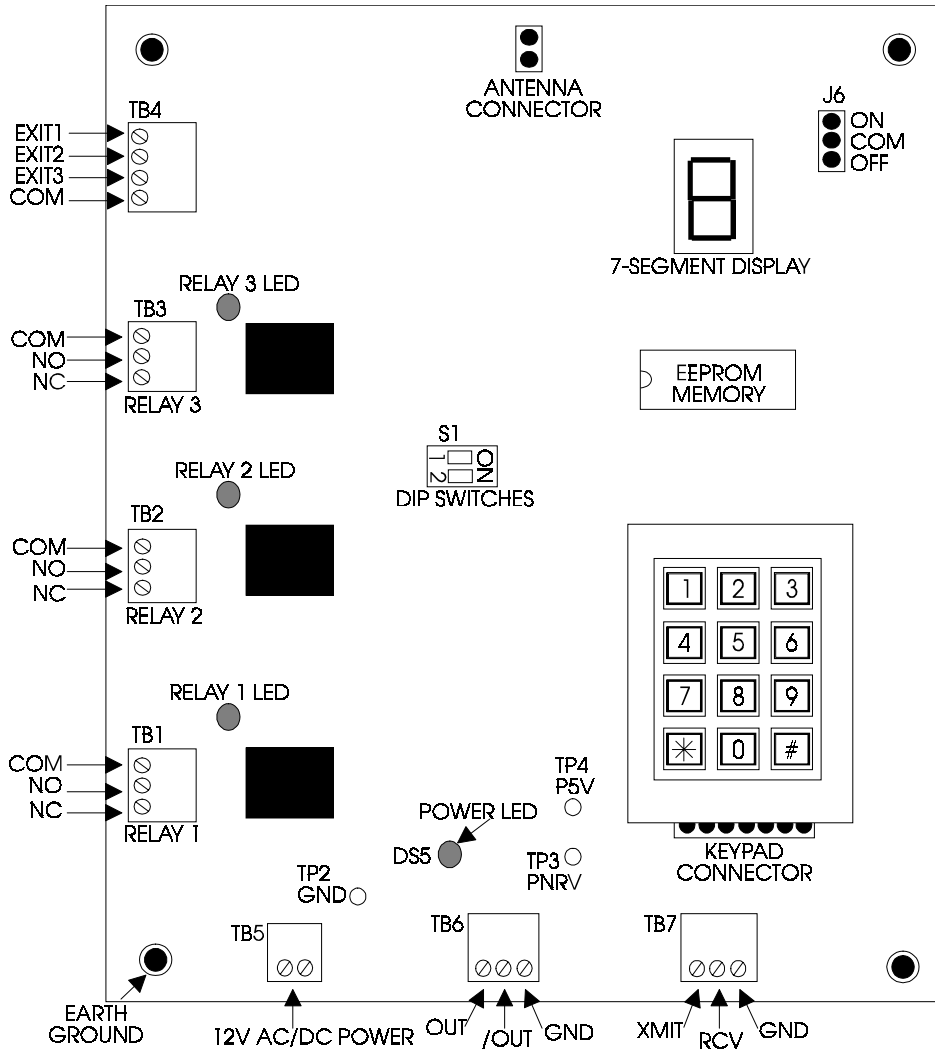

FCC REQUIREMENTS

INSTALLATION

This device complies with part 15, subpart J of the FCC rules. Operation is subject to the two following conditions: (1) this device may not cause interference, and (2) this device must accept any interference, including interference that may cause undesired operation of the device. On the front inside of the cabinet is a label which contains the FCC registration number for the unit, which is **DS8AKRCV**.

RADIO FREQUENCY INTERFERENCE

This equipment has been tested and found to comply with the limits for a Class B digital device, pursuant to part 15 of the FCC Rules. These limits are designed to provide reasonable protection against harmful interference when the equipment is operated in a residential environment. This equipment generates, uses, and can radiate radio frequency and, if not installed and used in accordance with the instruction manual, may cause harmful interference to radio communications. However, there is no guarantee that interference will not occur in a particular installation. If this equipment does cause harmful interference to radio or television reception, which can be determined by turning the equipment off and on, the user is encouraged to try to correct the interference by one or more of the following measures:

- Reorient or relocate the receiving antenna.
- Increase the separation between the equipment and receiver.
- Connect the equipment into an outlet on a circuit different from that to which the receiver is connected.
- Consult the dealer or an experienced radio/TV technician for help.

If necessary, the user should consult the dealer or an experienced radio/television technician for additional suggestions. The user may find the following booklet prepared by the FCC helpful: "How to Identify and Resolve Radio-Television Interference Problems". This booklet is available from the United States Government Printing Office, Washington D.C., 20402, Stock No. 004-000-00345-4.

IC REQUIREMENTS

All equipment that are certified under this Standard shall be labeled in accordance with RSP-100, and with the statement: "Complies with ISC:RSS-210; en conformité avec ISC:CNR-210". When size does not permit this, the statement may be abbreviated to "ISC:RSS/CNR210".

This device complies with RSS-210 of Industry and Science Canada. Operation is subject to the following two conditions: (1) this device may not cause interference, and (2) this device must accept any interference, including interference that may cause undesired operation of the device."