

9050 VEHICULAR SLIDE GATE OPERATOR



Metal Cover

Polypropylene Cover

Quiet, reliable & outstanding safety features

- Electronic magnetic limits eliminate old style mechanical switches that can wear out, break or fail
- Automatic self-setting limits mean no limit switch adjustments - ever
- Safety - built-in mechanical and electronic reverse system
- Advanced microprocessor control board features programming switches to set the mode of operation required and has ports for DKS plug-in loop detectors to simplify wiring
- 5-Year limited warranty

• RESIDENTIAL •

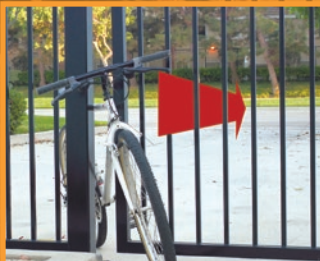

Entrapment Prevention
reverses gate when obstructed



Built In
power switch and reset switch



Fail-safe Release
never be locked out (or in)



Unique Design
allows easy access to all mechanical parts



9050 VEHICULAR SLIDE GATE OPERATOR

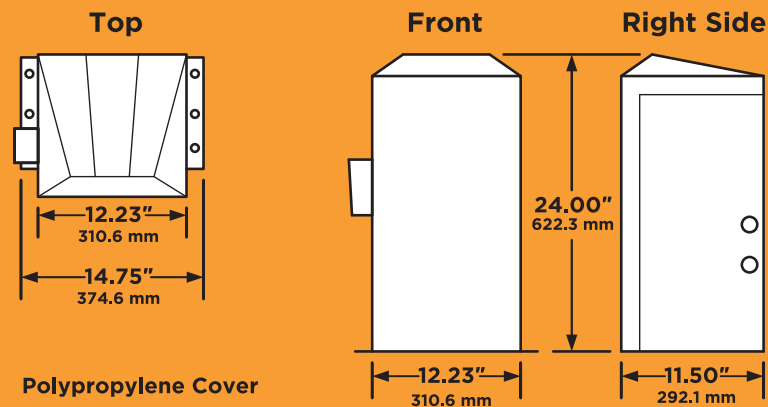
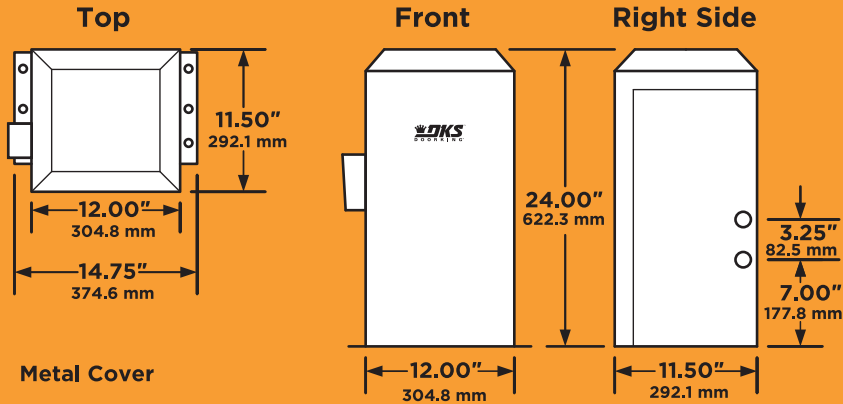

9050	
CLASS OF OPERATION	I
MAX GATE LENGTH*	16 ft (4.9 m)
MAX GATE WEIGHT*	500 lb (227 kg)
MOTOR	1/2 HP Continuous Duty AC Motor
INPUT	115 VAC, 60 Hz, 5.4A

* Assumes gate is on level ground, in good condition with properly adjusted hardware. Other external factors may affect the performance of the gate operator.

TECHNICAL FEATURES

MECHANICAL

- Frame: G90 galvanized steel to prevent rusting
- Cover: Steel or polypropylene cover
- Primary Reduction: Single cog belt
- Speed: Approximately 10 in/sec (254 mm/sec)
- Chain: Unit is shipped with 20 ft (6m) of #40 roller chain, chain brackets, hardware
- Fail-safe release standard

OPTIONS

- Heater kit for cold weather environments
- Base plate for post mounting
- Fail-secure release kit

ELECTRICAL

- Automatic limit adjustment
- Auto-close timer 1-23 sec
- Selectable stop / reverse loop function
- Built-in On / Off switch
- Built-in alarm reset switch
- Two 115 VAC convenience outlets for accessory transformers
- Automatically assumes fail-safe mode when an entrapment condition exists
- Ports for plug-in open and reverse loop detectors (DKS detectors only)

MISCELLANEOUS

- Environmental: 10°F to 140°F (-12°C to 62°C)
- Thermostatically controlled heater kit recommended for colder environments.
- Shipping weight approximately 70 lb (32kg)
- Operator requires monitored Type B1 and/or Type B2 entrapment protection devices

 Conforms To ANSI/CAN/UL 325:2017 Ed. 7
 Certified To CSA C22.2 #247
 Intertek

DoorKing® Inc.

Access Control Solutions since 1948



120 S. Glasgow Avenue,
 Inglewood, California 90301 U.S.A.
 Tel: 310-645-0023 FAX: 310-641-1586
 www.doorking.com

© 2020 All Rights Reserved.
 Product specifications may
 change without notice. Rev. 6/20



MEMBER:



DISTRIBUTED BY:

