

# AM-02

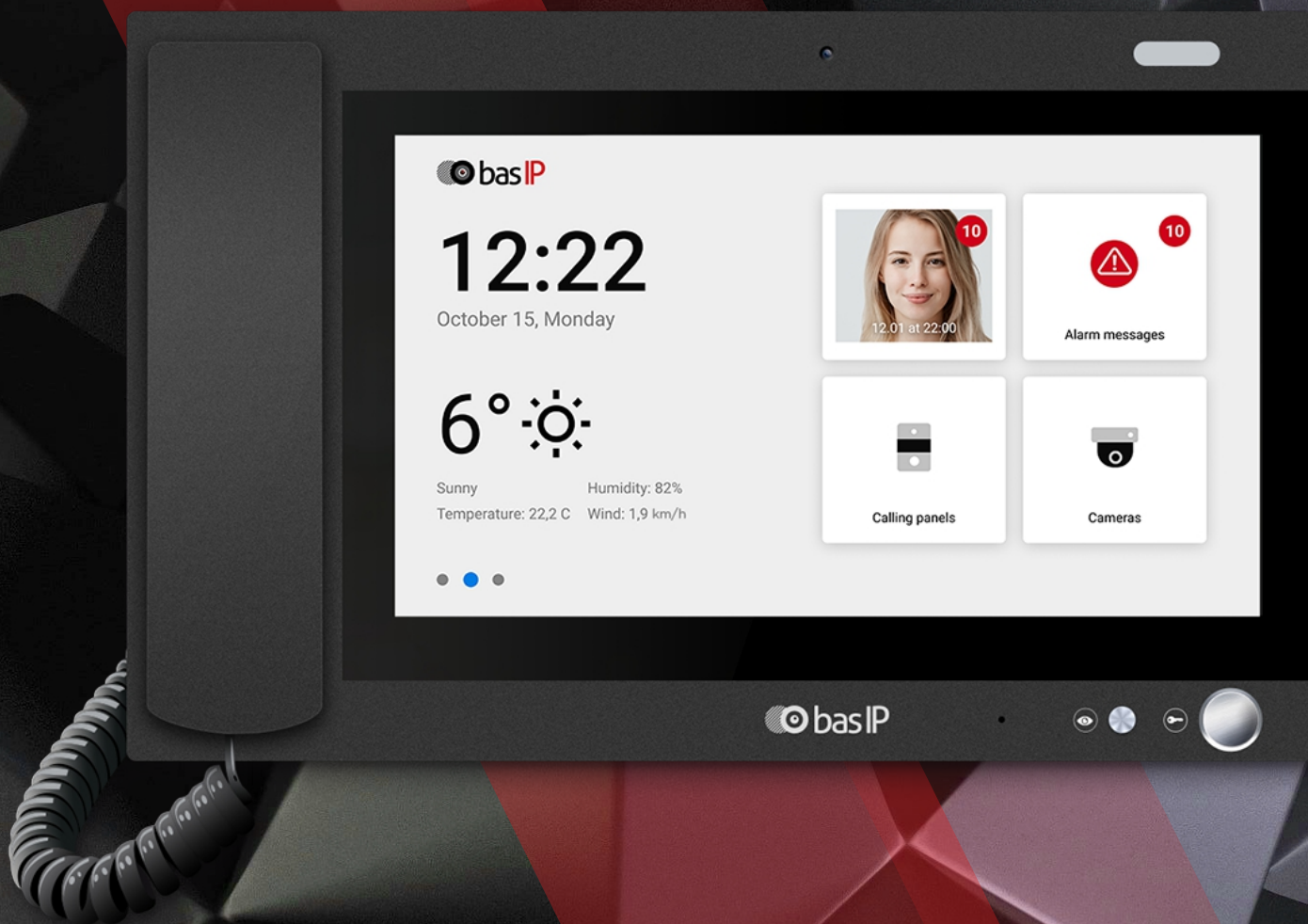



## Main feature

- Display: 10.1" TFT LCD, touchscreen.
- Power: PoE and + 12 V DC.
- Dimensions: 303 x 194 x 64 mm.
- Installation: Desktop installation.
- Colors: Black.
- Number of control buttons: 2.
- Lock control: Yes.

# CONCIERGE TERMINAL

# AM-02

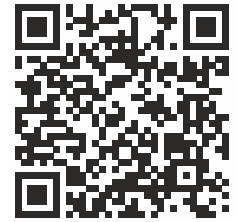

Full User Manual  
[wiki.bas-ip.com](http://wiki.bas-ip.com)

## Device description

The concierge terminal for convenient organization of communication with the whole system, with internal monitors, outside panels, receiving messages from the internal monitors and conducting confidential communication with visitors using the handset.

## Appearance

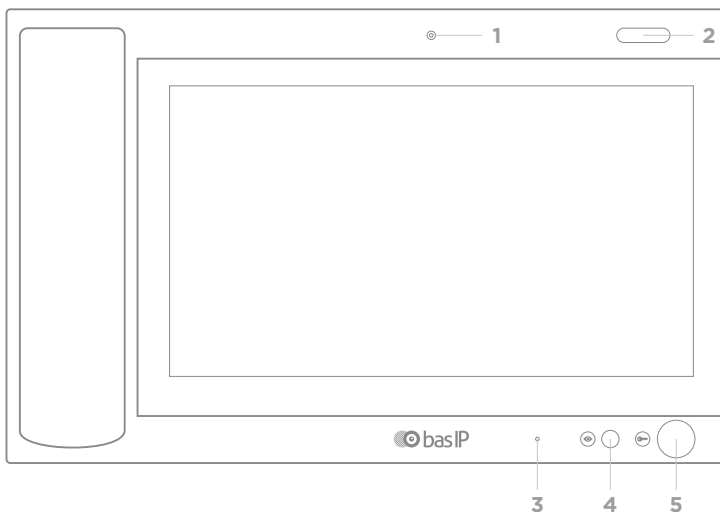

- |                    |                 |
|--------------------|-----------------|
| 1 - Camera.        | 4 - Monitoring. |
| 2 - Operation LED. | 5 - Open.       |
| 3 - Microphone.    |                 |

## Technical parameters

### Possibilities of connection:

IP camera support	up to 100 pcs
VoIP account support	1
Network connection	Ethernet 10 / 100 Base-T
Supported codecs	G.711, H.264

### Functional capabilities:

#### Interface:

- GUI
- WEB-interface

#### Additionally:

- 6 volume levels
- «Silent» mode
- «Do not disturb» mode
- SIP 2.0 protocol support

## Completeness check of the product

Before installation of the concierge terminal, it is necessary to check that it is complete and all components are available.

### Concierge terminal kit includes:

Concierge terminal	1 pc
Manual	1 pc
Set of wires with connectors for connection of power supply	1 pc
Table installation bracket	1 pc
Handset	1 pc

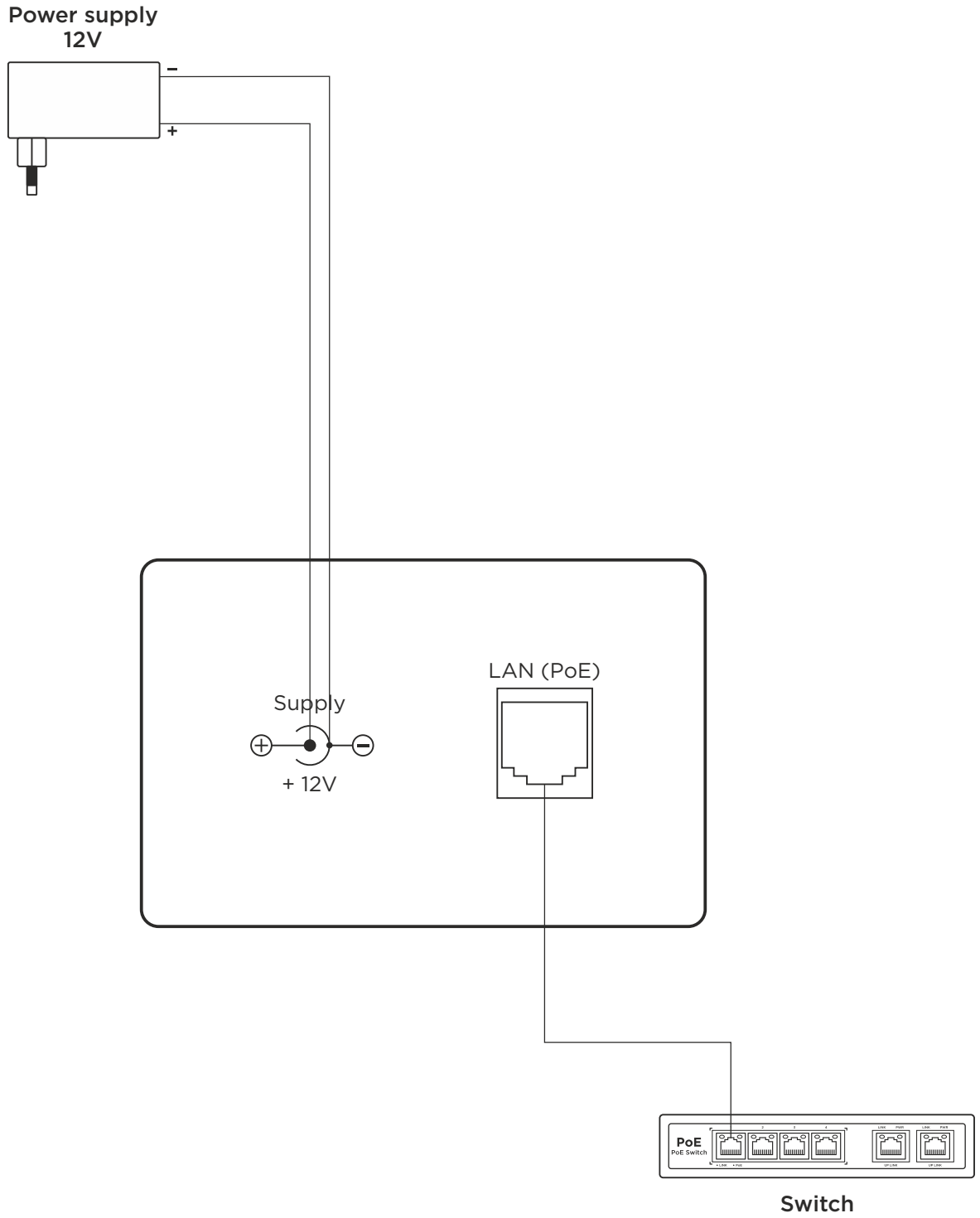

Connection powered by a 12 Volt power supply

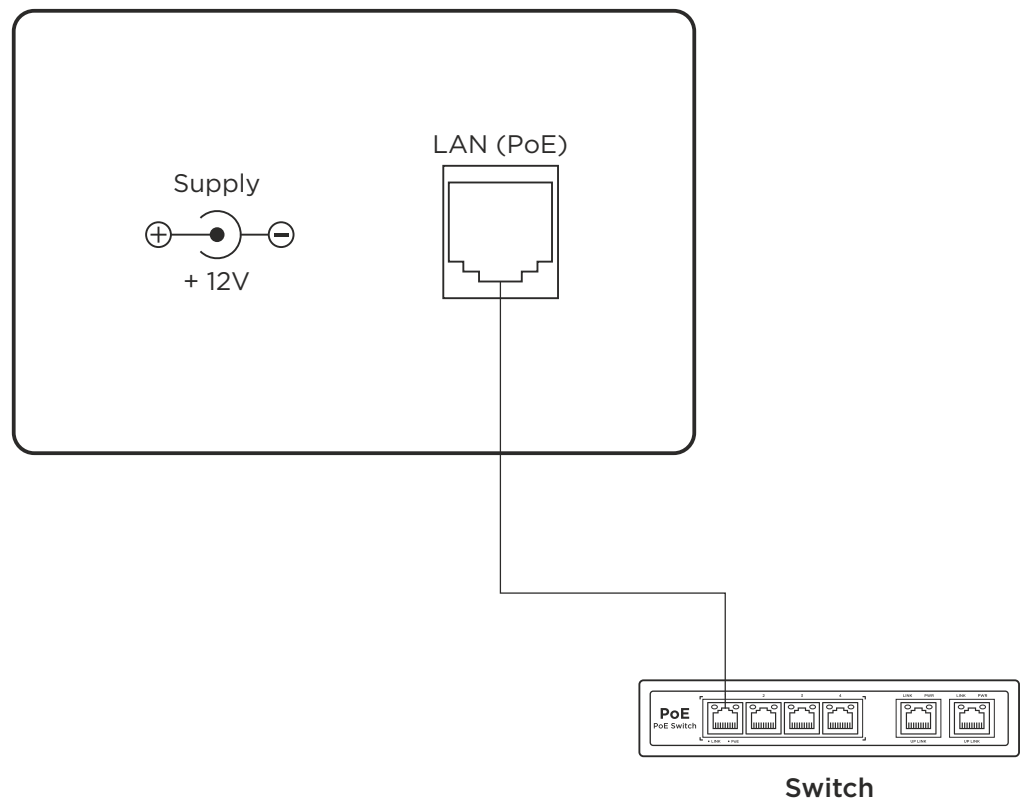

Connecting from a PoE Switch

## Warranty

The warranty card number \_\_\_\_\_

Model name \_\_\_\_\_

Serial number \_\_\_\_\_

Seller name \_\_\_\_\_

With following stated terms of warranty is familiar, functional test was performed in my presence:

Customer signature \_\_\_\_\_

## Warranty conditions

**The warranty period of the product — 36 (thirty-six) months from the date of sale.**

- Transportation of product must be in its original packaging or supplied one by the seller.
- The product is accepted in warranty repair only with a properly filled warranty card and the presence of intact stickers or labels.
- The product is accepted for examination in accordance with the cases provided by law, only in the original packaging, in a full complete set, appearance corresponding to the new equipment and presence of all relevant properly filled documents.
- This warranty is in addition to the constitutional and other consumer rights and in no way restrict them.

## Terms of warranty

- The warranty card must indicate the name of the model, serial number, purchase date, name of the seller, seller company stamp and the customer's signature.
- Delivery to the warranty repair is carried out by the buyer himself.
- Warranty repairs carried out only during the warranty period specified in the warranty card.
- The service center is committed to do everything possible to carry out the repair warranty products, up to 24 working days. The period spent on the restoration of product functionality is added to the warranty period.





[www.bas-ip.com](http://www.bas-ip.com)