



## Instruction Manual

The USVD-4X uses ultrasonic to reliably detect the presence of a vehicle in a wide variety of drive-thru applications including parking, access control, car wash, banking and fast food. The USVD-4X does not require the installation of an induction loop. It is simply mounted on a post and aimed at the desired location of detection. No additional set-up or functional adjustments are needed. The detection head consists of 4 ultrasonic transducers that scan the expected location for a vehicle and activates an output.

### Cautions and Warnings



This product is an accessory or part of a system. Install the USVD-4X according to instructions from the gate or door operator manufacturer. Comply with all applicable codes and safety regulations.

### Specifications

Power	12-24 VDC/AC
Standby Current	60 mA
Operating Range	1- 5 ft
Response Time	2.0 seconds
Relay Output Configuration	Form C (2 SPDT)
Relay Contact Rating	1A @ 24VDC
Operating Temperature	-40° to 182°F (-40° to 85°C)
Housing Material	ABS plastic
Dimensions (L x W x H)	3.6" (90 mm) x 2.3" (57 mm) x 5.7" (145 mm)

### Ordering Information

- USVD-4X      Ultrasonic vehicle detector, includes cable grip

# Connections & Wiring

## 1. Transducer Status LEDs

Individual transducer status LEDs flash when an echo from a surface is present 1-5 feet in front of the sensor.

## 2. Tuning Coils

*Do not adjust for any reason.  
This will permanently damage the unit.*

## 3. DIP Switch

Relay 1 & Relay 2 Delay	DIP Switch	
	4	3
No Delay	off	off
1 Second Delay	off	on
2 Second Delay	on	off
4 Second Delay	on	on

Relay 2 Pulse/Presence	DIP Switch	
	2	1
Presence	off	off
Pulse on Entry	off	on
Pulse on Exit	on	off
Pulse on Both	on	on

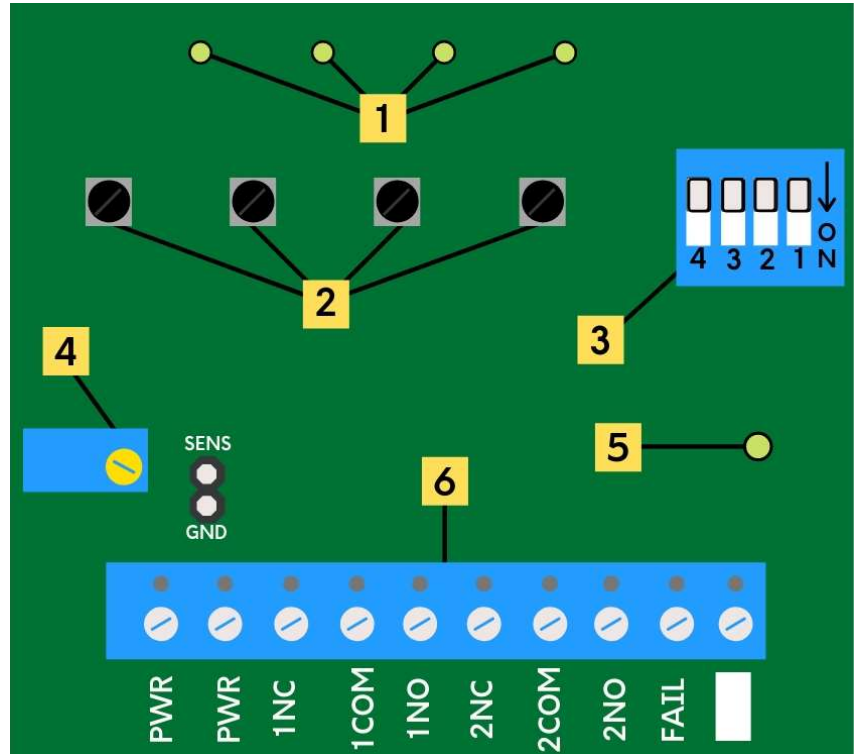

## 4. Sensitivity Adjustment

The sensitivity adjustment may be used to change the strength of the ultrasonic signal to increase or decrease the detection response. The factory setting is fully clockwise for maximum sensitivity.

## 5. System Status LED

Flashes green when powered on. Solid green when detecting an object.

## 6. Terminal Block

Terminal	Description
1	Power + (12-24 VDC/AC)
2	Power - (12-24 VDC/AC)
3	Presence Relay 1 - NC (normally closed contact)
4	Presence Relay 1 - COM (common contact)
5	Presence Relay 1 - NO (normally open contact)
6	Relay 2 - NC (normally closed contact)
7	Relay 2 - COM (common contact)
8	Relay 2 - NO (normally open contact)
9	Fail - Solid-State Output*
10	Spare Terminal

*\*The solid-state fail output is activated when a solid object, such as ice, is present preventing 1 or more transducers from vibrating.*

## Installation

1. Knock out the PG hole that will be used to pass the wires through.

2. Pass the body of the cable grip through the PG hole and tighten the backing to attach the cable grip to the housing.

3. Thread all wires through the cable grip and into the housing.

4. Turn off the power supply when connecting the USVD-4X power wires to the terminal block. The terminals are not polarity sensitive.

5. Wire the USVD-4X according to the operator instructions and the terminal block table.

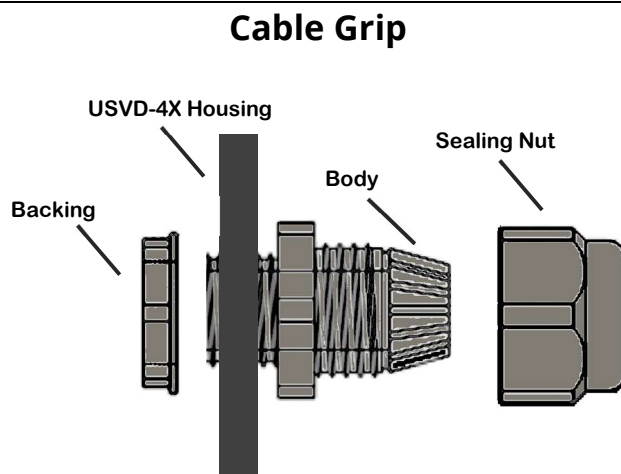

6. Configure the DIP switch to the pulse/presence and delay mode desired.

7. Mount the USVD-4X perpendicular to the side of the vehicle at the location of desired detection and 22-24" above the height of the pavement surface where the vehicle is located.

**TIP:**

If using multiple USVD-4Xs it may be necessary to place a barrier up to 24x24" between the sensors to prevent units from interacting.

8. Adjust the sensitivity by rotating the sensitivity adjustment counter-clockwise to decrease and clockwise to increase (#4 in image on previous page).

**TIP:**

- In most applications it is unnecessary to reduce sensitivity.
- If using multiple USVD-4Xs, it may be useful to reduce the sensitivity to reduce crosstalk.
- Two test points to the right of the sensitivity adjustment labeled GND and SENS may be used to measure the position of the sensitivity adjustment. 5V is the maximum sensitivity.

## Troubleshooting

Symptom	Cause	Solution
Constant detection	Solid material blocking transducer	<p>Increase the angle of the housing to avoid detection of the ground or other low objects.</p> <p>Turn down the sensitivity by 1V by rotating the sensitivity adjustment counter-clockwise. Attach a multimeter to the GND and SENS pins to the right of the sensitivity adjustment to read the change in voltage.</p>

## Warranty

EMX Industries, Inc. products have a warranty against defects in materials and workmanship for a period of two years from date of sale to our customer.