

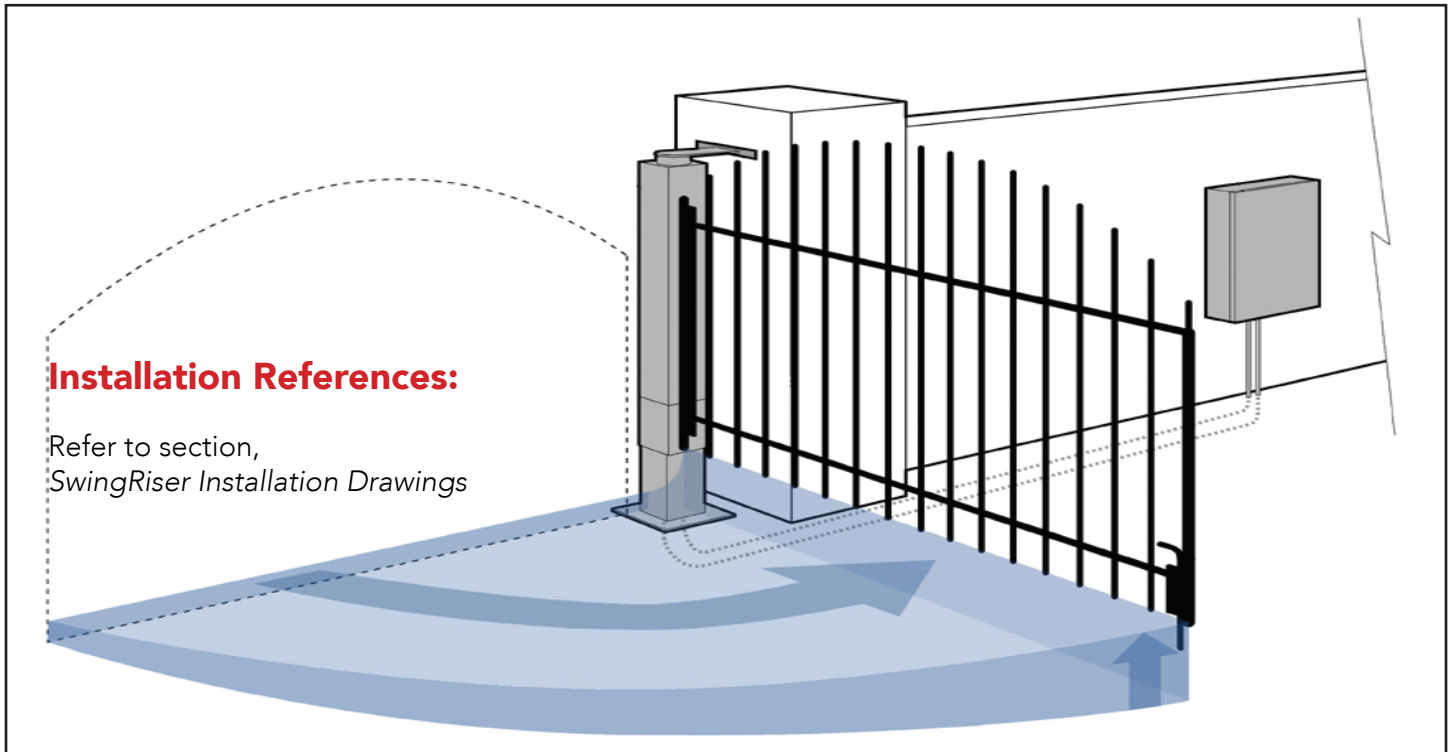

SwingRiser 14, 19, 30 (HRG 220)

SwingRiser 14 Twin, 19 Twin, 30 Twin (HRG 222)



**Programming & Operations Manual
with
HySecurity Smart Touch Controller
MX3654-01 Revision A**

This document provides *Important Safety Information, specifications, and references* along with an overview of programming user and installer menu options, designing vehicle loop layouts, troubleshooting, and maintaining the gate operator.



HySECURITY GATE OPERATORS: UL 325 – 2016

The following bullet points highlight how your automated gate system sites can monitor external entrapment protection using HySecurity gate operators:

- **Normally Closed (NC) sensors** – Before gate movement occurs, the gate operator verifies that the external entrapment protection sensor is connected and fully functional.
- **Build Year (BY)** – An added menu item distinguishes between pre-2016 manufacturing dates and UL 325 - 2016 manufacturing dates. Build Year (BY) is a factory-setting. Build Year 2 (BY 2) is the default for all HySecurity gate operators indicating a manufacturing date of 2016 in the serial number. Replacement controller boards for existing sites allow for a Build Year setting of 1 (BY 1) (pre-2016).
- **Independent Sensor Inputs** – The edge, photo eye and photo eye COM inputs on the Smart Touch and Smart DC Controllers (STC and SDC) have been re-labeled. The same wiring connections become three independent methods for easy entrapment protection sensor configuration and normally closed outputs.

Table 1: HySecurity Gate Operators requiring External Monitored Entrapment Protection Sensors

HySecurity Gate Operators (includes Modular, Correctional, and UPS models)	Build Year UL 325 - 2016 (set at the factory)	UL 325 Entrapment Protection Sensor Monitoring Required Normally Closed (NC) sensors tested & approved. Three SENSOR Inputs on Controller. Installer Menu configurable. Build Year (BY) factory-set to UL 325 - 2016.
SlideDriver 15, 40, 30F, 50VF 2/3, 80, 200	2	●
SlideDriver 50VF series	2	●
SlideSmart DC 15 & DCS 15	2	●
SlideSmart DC 10F & DCS 10F	2	●
SwingRiser 14, 14-Twin, 19, 19-Twin, 30, 30-Twin	2	●
SwingSmart DC 20 & DCS 20	2	●
HydraSwing 40, 40F, 40-Twin, 40F-Twin, 80F, 150	2	●
HydraLift 10, 10F, 20, 20F	2	●

Table 2: HySecurity Gate Operators maintaining Object Detection

Table 2 indicates those HySecurity gate operators that may be within the exception parameters of UL 325 or comply with standards other than UL 325, but continue to maintain object detection capabilities. HySecurity strongly recommends that you assess every site for entrapment zones and provide the necessary protection to guard against entrapment.

HySecurity Gate Operator's with Obstruction Protection (Object Detection)	Build Year UL 325 - 2016	Sensor Inputs automatically set to "NOT USED" Installer has option to change settings as site design dictates.
StrongArm (HTG) 14, 20, 28, 36	2	●
StrongArmCRASH (M30/M50)	2	●
StrongArmPark DC 10 & DCS 10 StrongArmPark DC 14 & DCS 14	2	●
WedgeSmart DC 10 & 10 DCS	2	●
WedgeSmart DC 14 & 14 DCS	2	●
HydraWedge SM50	2	●

External Entrapment Protection Sensors monitored by HySecurity Gate Operators

Any external entrapment protection sensor may be monitored by HySecurity gate operators, provided the following requirements are met:

- Sensor is marked as certified to UL 325 Standard of Safety by a Nationally Recognized Test laboratory, such as UL or ETL.
- If the sensor only has a normally open (NO) output with a 8.2K Ω or 10K Ω resistor, such as an edge sensor, then a conversion device must be used to convert the NO resistor output to an NC output. Example of two different installation methods:
 - * Method A - Wired
Connect the edge sensor to a NC conversion module (GEM-104 or GEM-204) and connect the module to the operator controls according to the manufacturer's instructions.
 - * Method B - Wireless
Connect the edge sensor to a UL 325 certified wireless edge transmitter and connect a matching receiver to the operator controls according to the manufacturer's instructions.

A resource list is available from the drop down [Gate Safety menu](#) on the [HySecurity website](#). The HySecurity recommended list shows examples of external entrapment protection sensors available for NC monitoring of automatic gate operators. All HySecurity gate operators manufactured after January 1, 2016 using software versions h4.50 or h5.50 (or later) comply with UL 325 Standard of Safety for monitoring entrapment protection sensors using normally closed contacts.

The site designer or installer must determine which external entrapment protection sensors will be installed with the gate operator to create a UL 325 compliant automatic gate operator site.

The UL 325 Standard of Safety and ASTM F2200 define the MINIMUM gate site requirements. Gate site, gate hardware, gate usage and other conditions may dictate the use of additional entrapment protection sensors. It is up to the gate system designer and installer to assess appropriate gate safety design and install the components required to protect all potential entrapment zones. Always check your local area codes and comply with all standards and regulations.



Temperatures and environmental conditions affect proper operation of external entrapment protection sensors. Always check the manufacturer's specifications shipped with the sensors. Consult the manufacturer's instructions for correct wiring connections, hardware installation and proper operation.

SwingRiser Post & HydraSupply Components

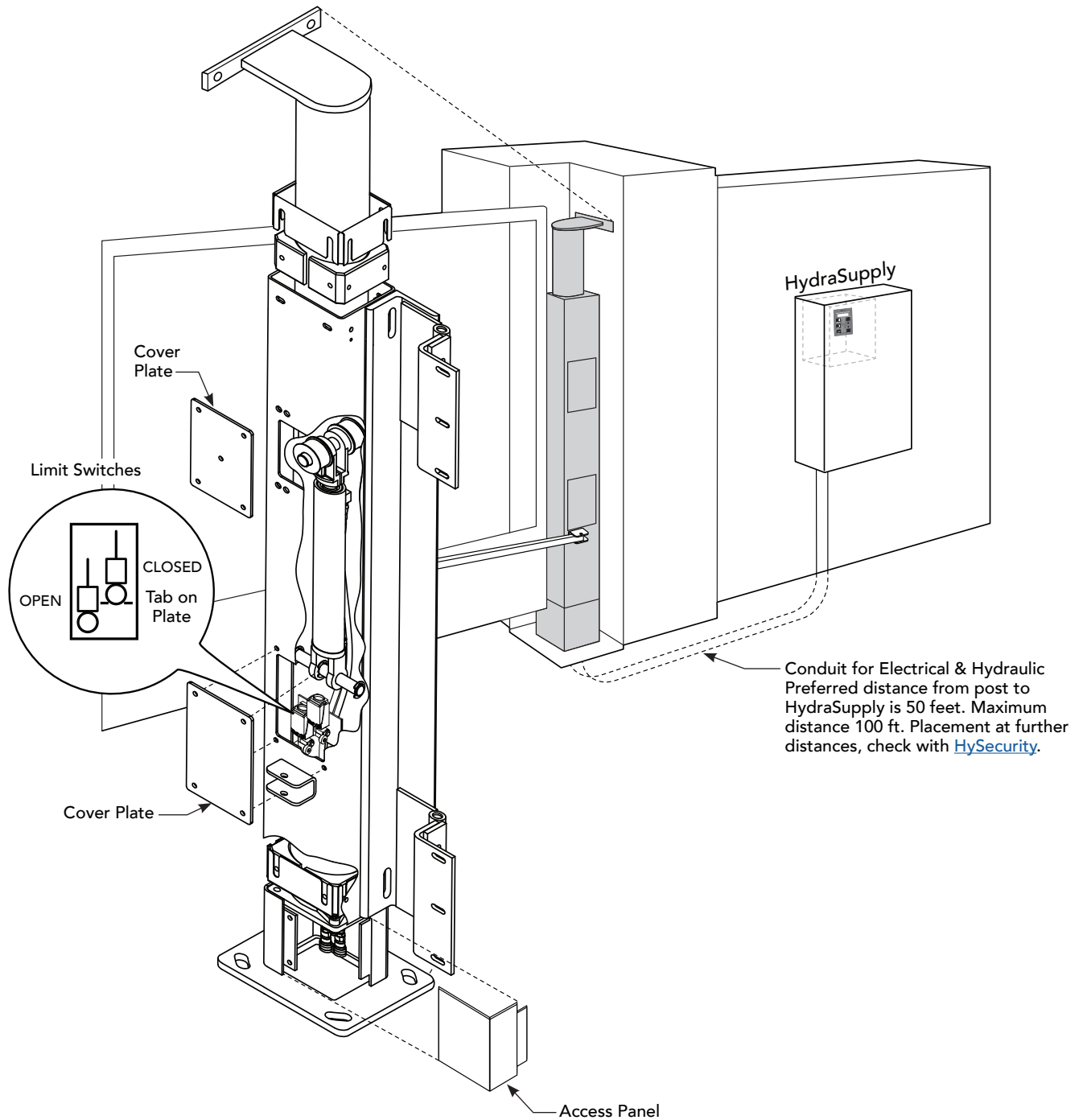

SwingRiser Components

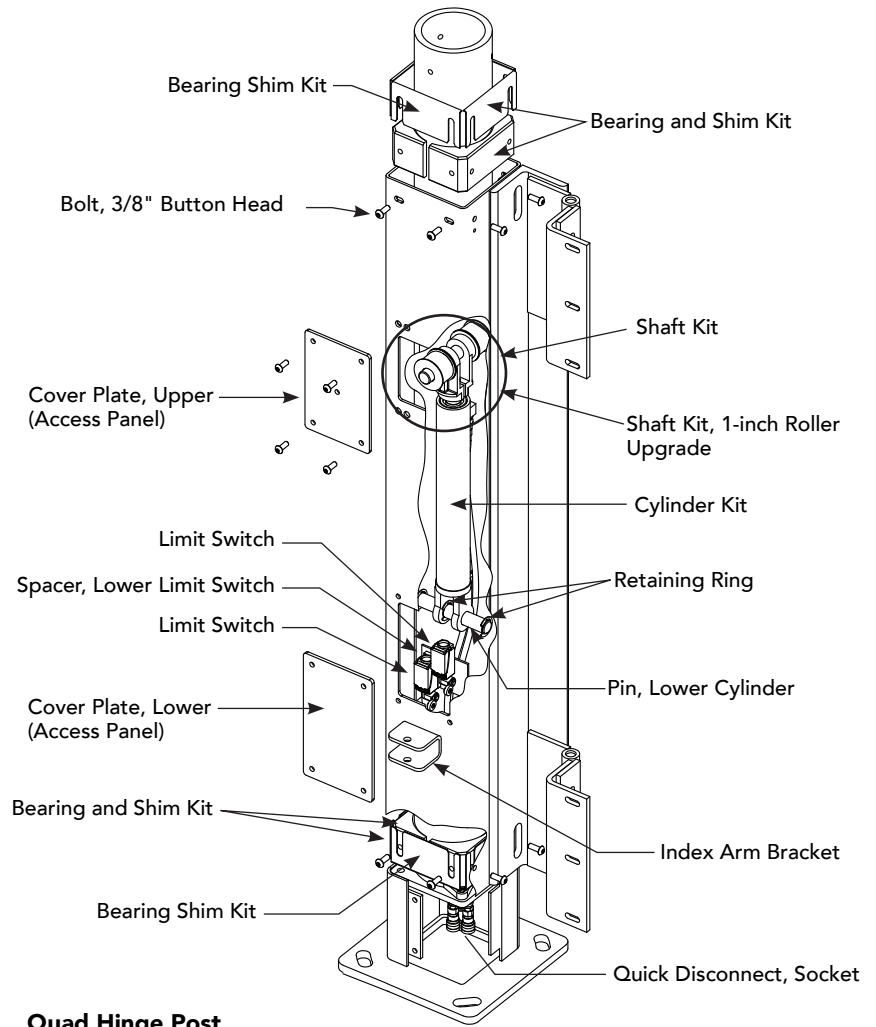

Triple Hinge Post

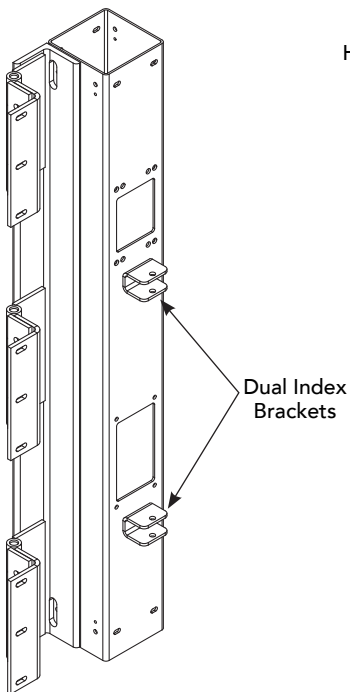

Quad Hinge Post

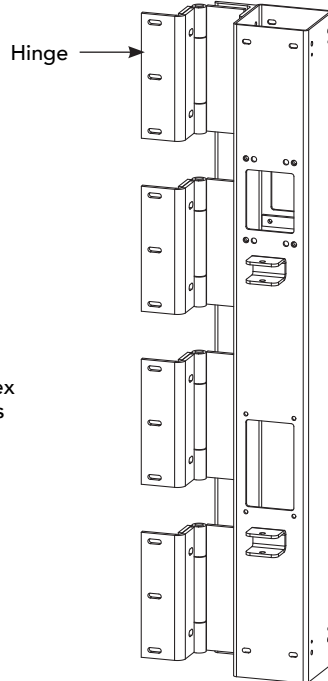

HydraSupply Internal Components

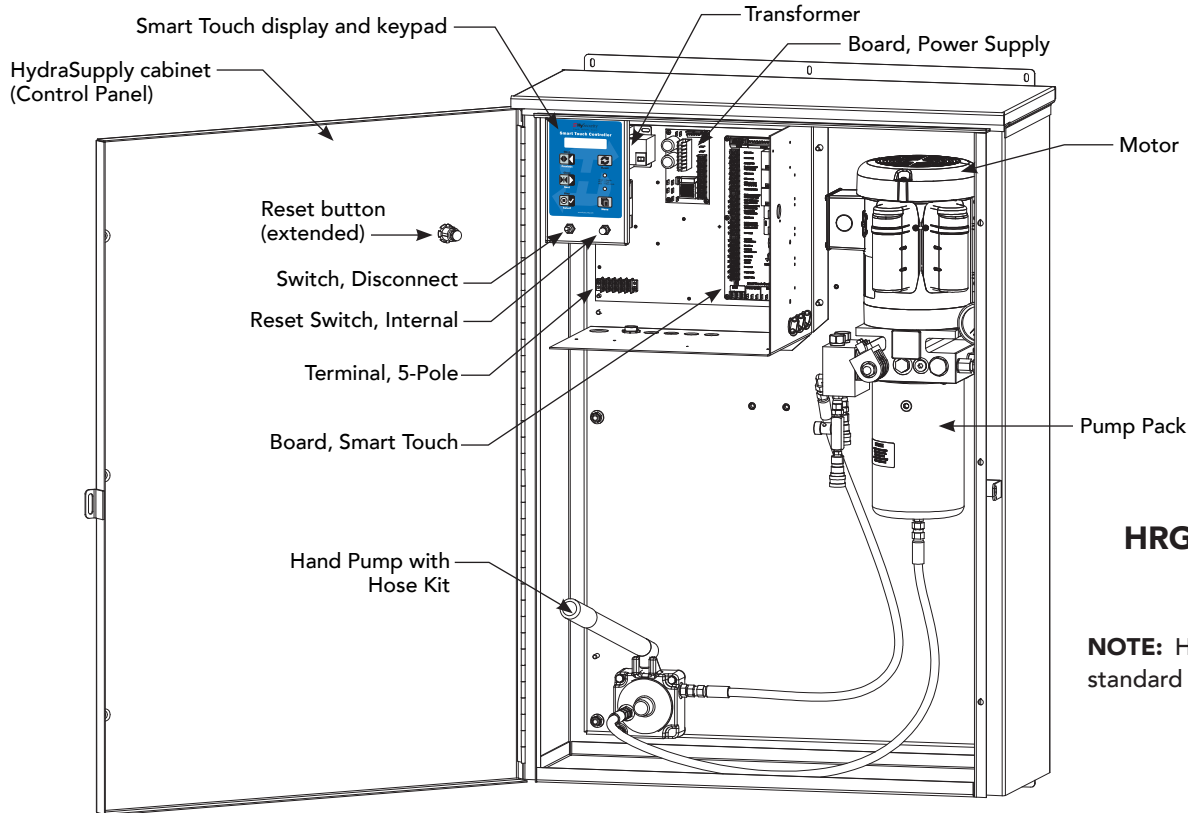

HRG 220

NOTE: Hand pumps are standard in all HRG models

HRG 222



Stop/Reset Button
Membrane Switch KEYPAD

NOTE: Be certain to match the color coding on the Quick Disconnects both at the Flow Control Valves and at the base of the operator post. This is to ensure a correct connection.

NOTE: Hand pump shown for historical purposes only. It has been replaced with a hand pump similar to the illustration shown in the HRG220.

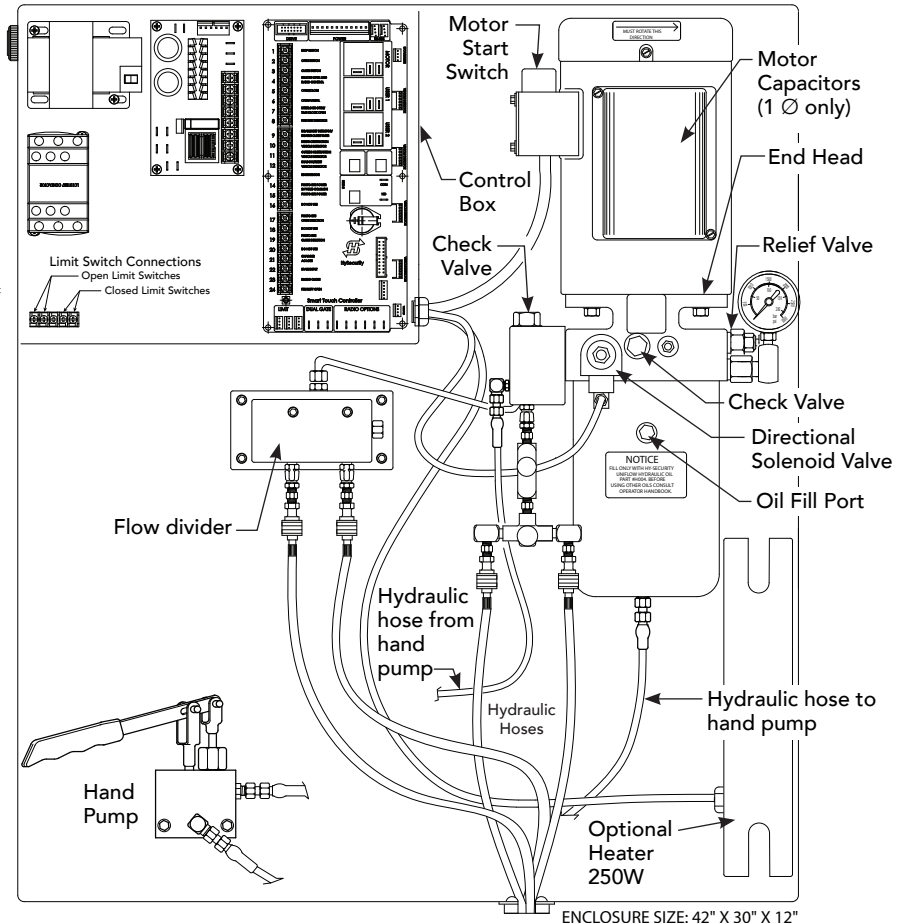

SwingRiser Pump Pack Components

Pump Pack, Single (HRG 220)

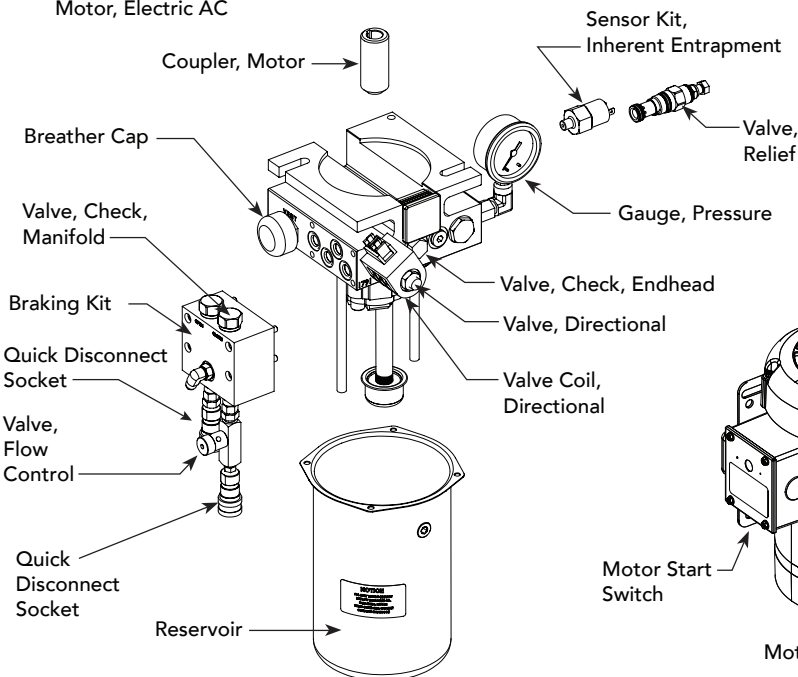
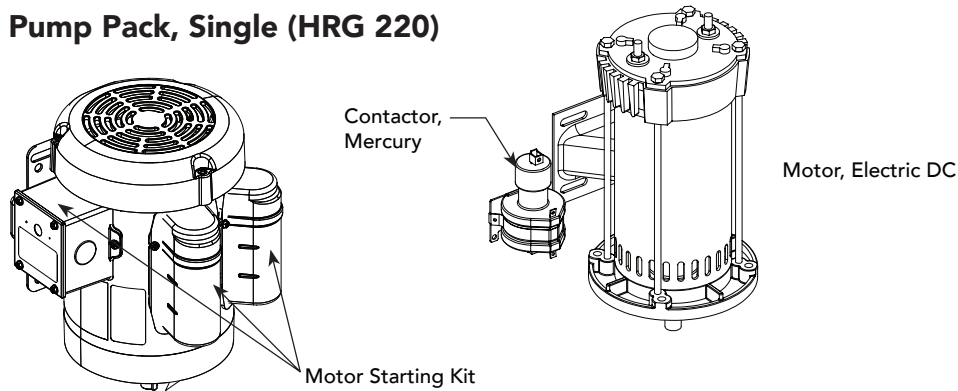

Pump Pack, Twin (HRG 222)

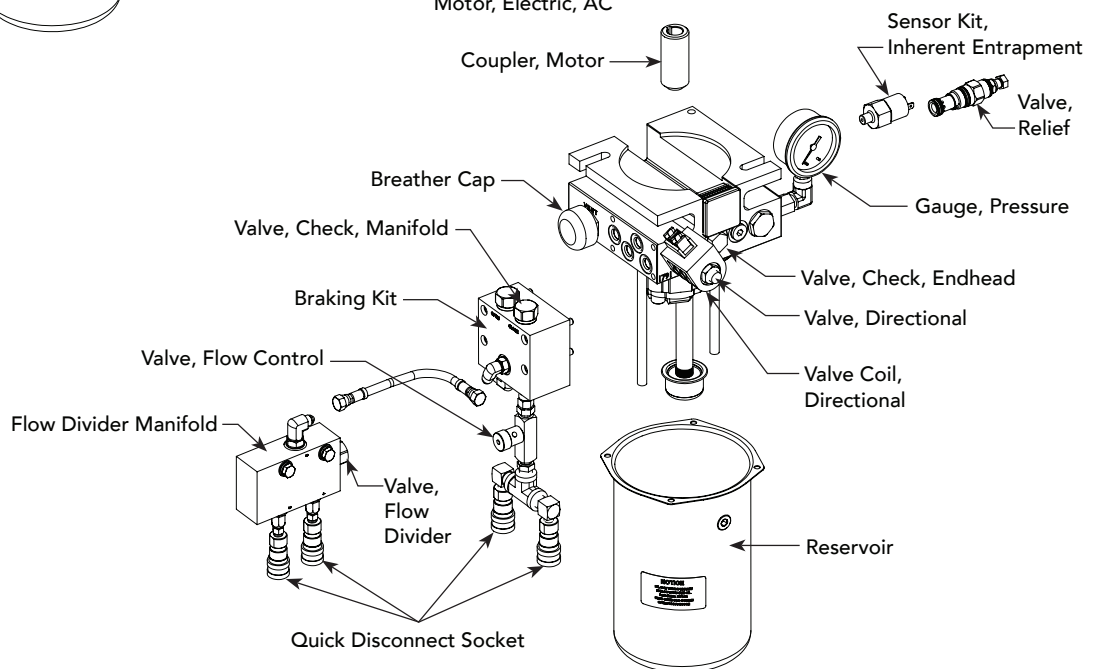
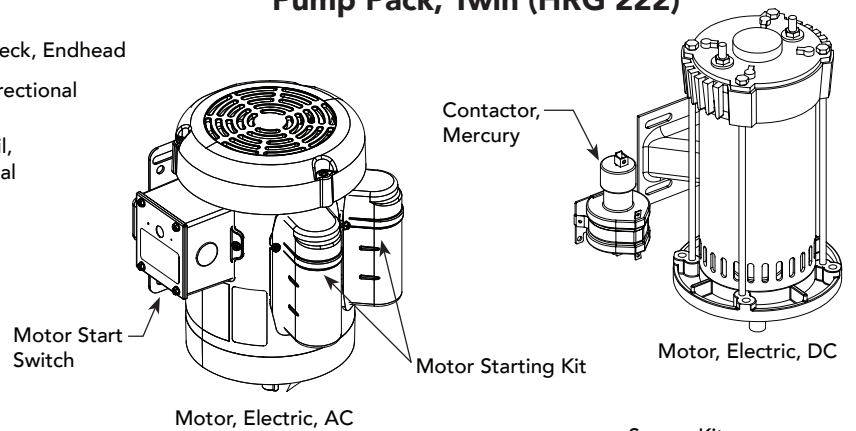

AC POWER SUPPLY WITH HYINVERTER AC

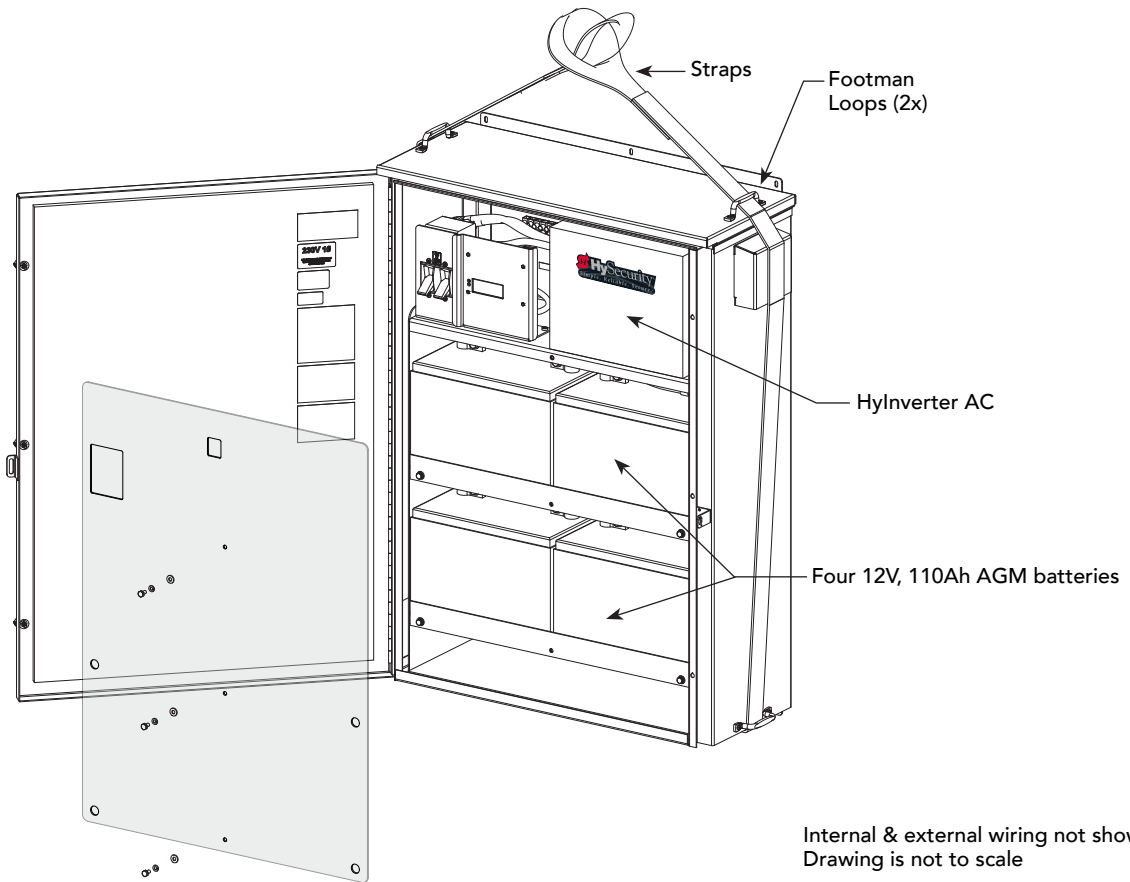

DC POWER SUPPLY WITH HYCHARGER™ DC

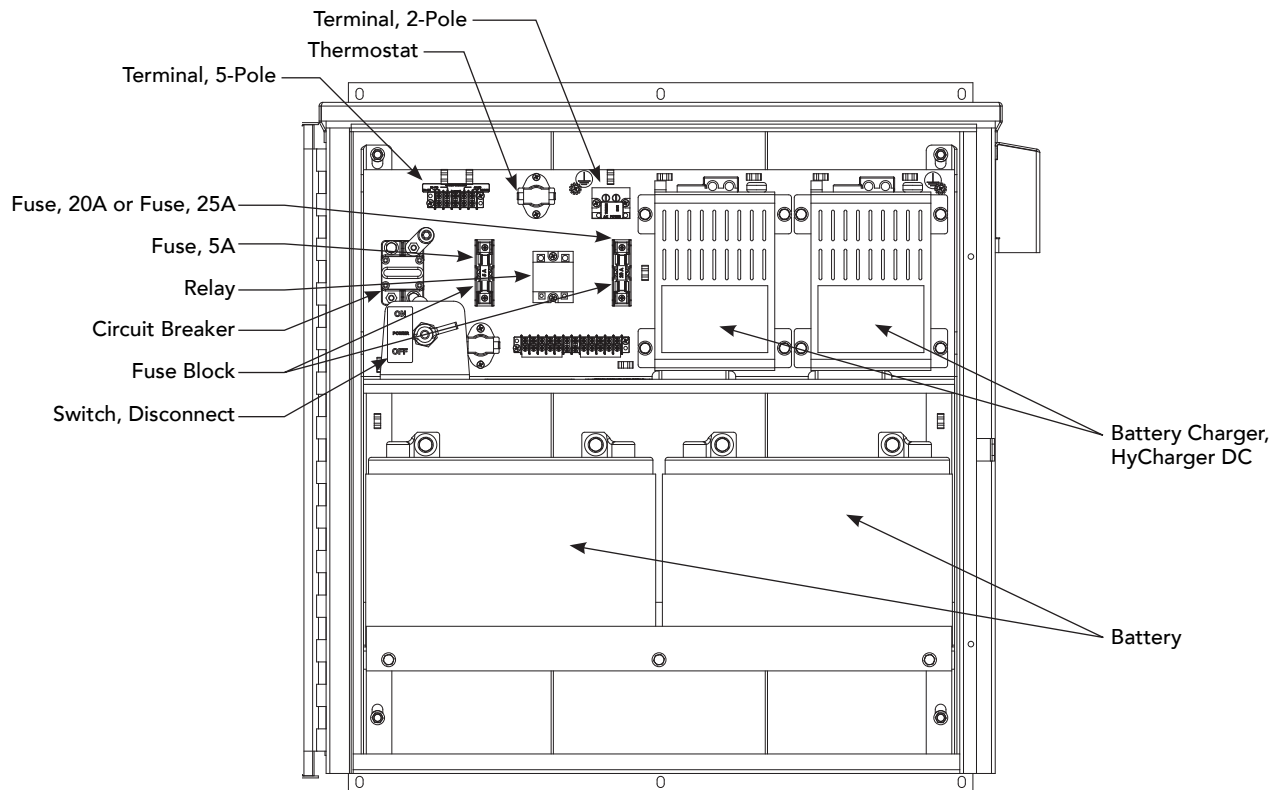

Contents

HySecurity Gate Operators: UL 325 – 2016	ii
Table 1: HySecurity Gate Operators requiring External Monitored Entrapment Protection Sensors	ii
Table 2: HySecurity Gate Operators maintaining Object Detection	ii
External Entrapment Protection Sensors monitored by HySecurity Gate Operators	iii
AC Power Supply with HyInverter AC	viii
DC Power Supply with HyCharger™ DC	viii
Site Planning Samples	xiv
Gate Opens Perpendicular to a Wall	xiv
Gate Opens to Empty Space	xiv
WELCOME TO HySECURITY	1
Contact Information	2
Notices and Bulletins	2
Supplemental Documents	2
IMPORTANT SAFETY INFORMATION	3
Safety - Additional Installer Responsibility	4
Identifying Gate Operator Category and Usage Class	5
Safety - Additional Installer’s Responsibility, continued	6
Safety - Owner/User Responsibility	7
Hazardous Materials and Proper Disposal	7
Breather Cap Installation and Grounding	8
Emergency Stop Button	9
Flow Control Valve – CLOSE Direction	9
Releasing the Gate: Manual Operation	10
Option 1: Release the Gate	10
Option 2: Open the Gate using the Hand Pump	10
Option 2: Close the Gate using the Hand Pump	10
Wind Load Considerations	11
Safety Notices	12
Common Industrial Symbols	12

POWER.....13

- Installing the Earth Ground13
 - Site Considerations.....14
- Wiring AC Power.....14
 - Turning the Power Switch ON.....15
- Wiring Diagram: Smart Touch Controller System.....16
- Wire Sizing and Runs.....17
 - Low Voltage Control Wiring.....17
 - SwingRiser Wiring Charts (Incoming Power)18
- UPS Backup Power Options19
 - DC Power Supply (UPS) Connections19
 - AC Power Supply with HyInverter AC.....20

INITIAL SETUP.....21

- SwingRiser Order Form.....21
- Gate Handing.....22
- Adjusting the Pressure Relief Valve23
- Adjusting the Gate Speed.....24
- Installation Overview.....24

ENTRAPMENT PROTECTION25

- Manufacturer’s responsibility.....25
 - Pressure Relief Valve – All Hydraulic Operators:25
 - Inherent Entrapment Sensor System – Hydraulic Operators (IES)26
- The Inherent Entrapment Sensor (IES)26
- How Software Handles Monitoring External Entrapment Protection Sensors27
 - Table 3: Changes to Sensor Inputs on the Controller.....27
- External Entrapment Protection Sensors: What the Installer Needs to Do.....27
 - Table 4: Installer Menu Settings for SENSOR Inputs29
- Supply Power to the Sensors30

CONTROL PANEL OVERVIEW.....31

- STC Board, Power Supply Board and Display.....32

DISPLAY & MENU OPTIONS.....33

- Understanding the Display and Keypad33
- Initial Setup34
 - Initial Setup Using S.T.A.R.T.35
- Menu Mode and the STC Keypad36
- Menu Mode Navigation36
- Run Mode and the STC Keypad37
- Viewing Gate Operator Scrolling Status37
 - Stop the Status Display Scrolling38
 - Change the Contrast on 7 Segment Displays.....38
 - Display Power Saving Mode39

Check the Software Version	39
Check Time and Date	39
User Menu	39
Table 5: User Menu	40
Installer Menu	42
Table 6: Installer Menu	42
Setting the Close Timer	49
Test the Operator	50
STC INPUTS & WIRING	51
Overview of the STC and Power Supply Board.....	52
Integrating with Security Systems and HyNet™ Gateway	53
Smart Touch Controller Inputs.....	54
STC Terminal Inputs	54
User Relays – Programming Procedure	57
Table 7: Programmable User Relays.....	57
Hy8Relay Module Option.....	60
BI-PARTING & DUAL GATE SYSTEMS	61
Connecting an Interlocked Pair (Dual Gate).....	61
Dual Gate Wiring Connections	62
Dual or Sequenced Gates: Power, Software & Accessory Requirements	63
Programming a Dual Gate (Interlocked Pair)	63
Connecting Sequenced Gates	64
Sequenced Gate: Configuration #1	66
Sequenced Gate: Configuration #2	67
VEHICLE DETECTOR INSTALLATION AND LOOP LAYOUTS	69
Anti-TailGate Mode (Closing Logic).....	69
TailGate Alert	69
Vehicle Detectors and the Smart Touch Controller	70
Hy5B Installation	70
Test the Vehicle Loop.....	70
Check the Version of Software	71
Install Hy5B Vehicle Detectors	71
Installing Standard 11-Pin Box Type Vehicle Detectors.....	73
Loop Layouts: Single Lane, Bi- or Single-Directional	74
Loop Layouts: Two Lane, Bi-Directional	75
PHOTO EYE INSTALLATION	77
Photo Eyes (Non-Contact) Installation	78
Compatibility	78
Installation.....	78
Configuration	79
Photo Eye Connections: Smart Touch & Smart DC Controllers	79

Photo Eye Function.....	79
Retro-Reflective Photo Eye Systems.....	80
Using Photo Eye Sensors instead of Vehicle Loops	81
Photo Eye Alignment Feature	82
INSTALLING GATE EDGE SENSORS.....	83
Compatibility	84
Installation.....	84
Gate Edge Function.....	84
TROUBLESHOOTING	85
System Diagnostic Messages.....	85
Table 8: Troubleshooting Codes.....	86
Access the Event Log through the User Menu	91
Electrical Issues	92
AC-Powered Gate Operators.....	92
Mechanical Issues.....	93
Hydraulic Issues.....	93
Typical Problems and Troubleshooting Procedures	94
GENERAL MAINTENANCE	97
Smart Touch Analyze and Retrieve Tool (S.T.A.R.T.).....	97
What You Need.....	97
Installing S.T.A.R.T. Software.....	97
Software Maintenance.....	98
Electrical Controls	98
Clock Battery Replacement	98
Mechanical Maintenance	99
Operator Post	99
SwingRiser Index Arm Assembly.....	104
Hydraulic System Maintenance	105
Adjusting the Pressure Relief Valve	106
Open Valve	106
Adjusting the Flow Control Valve	106
Bleeding Air from SwingRiser Hoses.....	108
SwingRiser Operator Maintenance Schedule.....	108

WIRING HySECURITY SENSORS: SMART TOUCH 109

Wiring Tips for SENSOR COM Terminal: Smart Touch 110

Menu Mode Navigational Tips..... 110

Smart Touch: Wired Edge Sensor with GEM (-104)..... 111

Smart Touch: Photo Eye Thru Beam (EMX IRB MON)..... 112

Smart Touch: Photo Eye / Reflective (E3K R10K4) 113

Smart Touch: The Solution, MIM-62 (Multi-input Module)..... 114

Smart Touch: Photo Eye / Reflecti-Guard (RG-R)..... 115

Smart Touch: Wireless Edge, Wireless Gate Link..... 116

Smart Touch: Wired Edge with GEM-104 & Photo Eye 117

Smart Touch: WireLess Edge Gate Link & Photo Eye 118

SWINGRISER INSTALLATION DRAWINGS 119

SwingRiser: Gate Swing and Pillar / Post Views 119

SwingRiser Twin: Site Sketch 119

SwingRiser Post: Top Cap Options 120

SwingRiser Post: Components 121

SwingRiser Posts & Installation Reference..... 122

SwingRiser Posts & Gate Site: Overview 123

SwingRiser Single (HRG220): Installation Reference 124

SwingRiser Twin (HRG 222): Installation Reference 125

SwingRiser: Index Arm & Locking Pin OverView..... 126

SwingRiser: Post Mount Locking Pin Installation..... 127

SwingRiser: Ground Locking Pin Installation 128

SwingRiser: HydraSupply Installation Overview 129

WARRANTY 131

Specifications 132

SITE PLANNING SAMPLES

Gate Opens Perpendicular to a Wall

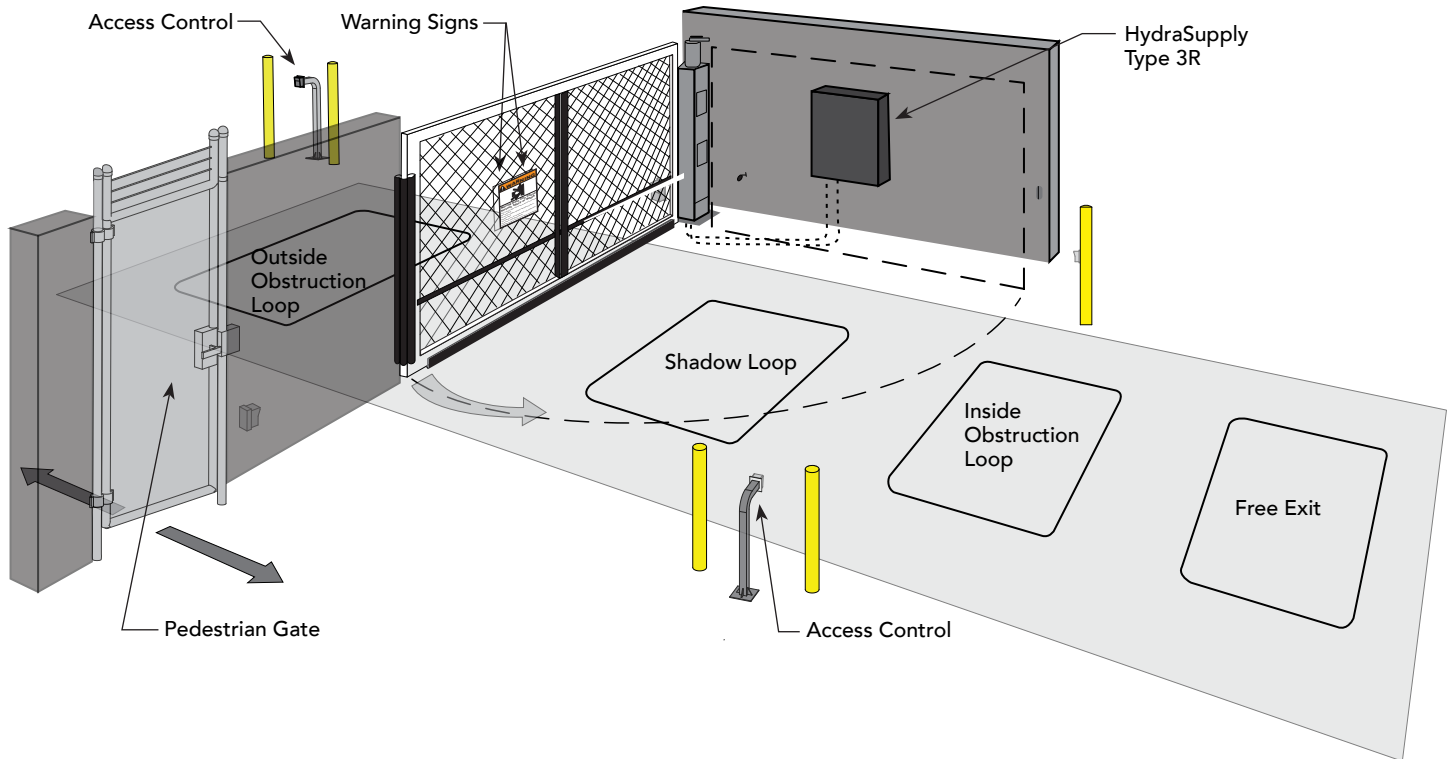

Determine site plan based on your site's specific layout. Considerations include:

- The swing gate operator automates the gate. SwingRiser may be ordered with left or right handing.
- The HydraSupply control box (Type 3R) houses the Smart Touch Controller (STC) and hydraulics.
- An access control opens the gate.
- Shadow loop prevents the gate from closing on a vehicle. The shadow loop is active only when the gate is fully opened or fully closed.
- Obstruction loops (reversing loops) located on the public and secure sides of the gate.
- Optional Free Exit loop.

For more information on loop layout, refer to *Vehicle Detector Installation and Loop Layout* on page 67.

Gate Opens to Empty Space

Loop layouts and entrapment protection elements required in both designs. Always comply with UL 325 Standard of Safety.

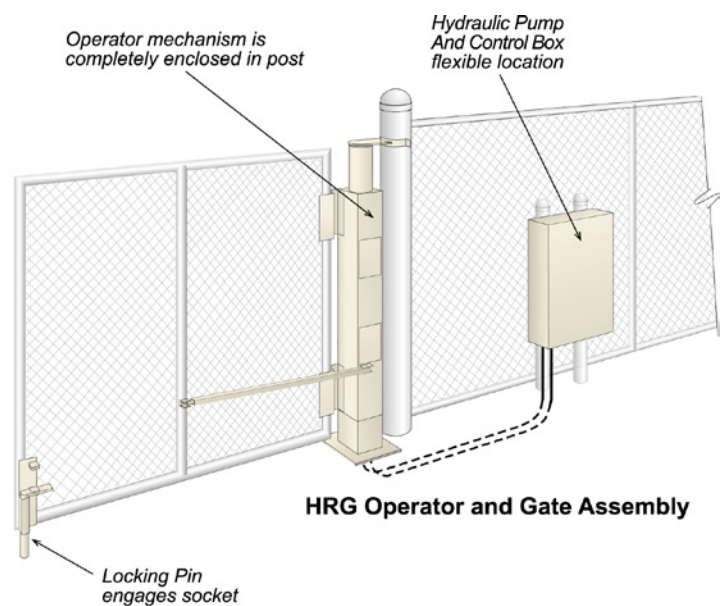

Welcome to HySecurity

Thank you for purchasing our premium SwingRiser™ gate operator. HySecurity Gate, Inc. has manufactured some of the finest, sturdiest, most innovative, and reliable hydraulic gate operators since the 1970s. We use the same hydraulic technology common in the aircraft industry while incorporating software capabilities that far exceed the competition.

All operator designs are tested for hundreds of thousands of cycles before being released to the market. Slide, swing, traffic barrier, fortified crash barrier and vertical lift operators have all received rigorous testing and certification. Security, low maintenance, flexible configuration, and overall toughness are the foremost criteria for all HySecurity products.

Our commitment to quality and innovation will become evident as the features and performance of the expertly engineered and manufactured SwingRiser become familiar to you. Thank you again for the confidence you've shown in becoming part of the HySecurity family and in choosing a premium, industry-leading product.



HySecurity Gate, Inc. Headquarters in Kent, WA

CONTACT INFORMATION

Qualified HySecurity distributors are experienced and trained to assist in resolving any problems.

Before contacting your distributor or HySecurity Technical Support, obtain the serial number of your operator.

For information about HySecurity training for installers, maintenance personnel, and end users, refer to the company website.

NOTICES AND BULLETINS

Installers should contact HySecurity prior to installing product to make sure they have received the most up-to-date information.

SUPPLEMENTAL DOCUMENTS

The product literature is comprehensive and contains information needed to plan, install, operate and maintain your gate operator. Additional general information concerning HySecurity gate operators can be obtained from the following:

- The [gate safety section](#) of the HySecurity website contains published materials regarding industry changes due to UL 325 - 2016 requirements involving external entrapment protection sensors.
- Links to the product catalogs, [product order form](#), [operator manuals](#), operator software downloads, technical support bulletins and other useful information.
- [S.T.A.R.T. User's Guide \(D0049\)](#) - Smart Touch Analyze and Retrieve Tool - details the extensive software, diagnostic and troubleshooting capabilities of the Smart Touch Controller board.
- DC Power Supply with HyCharger DC, supplement
- AC Power Supply with HyInverter AC, Installation and Reference Manual
- Technical Bulletins (as applicable).

NOTE: Technical Bulletins are automatically issued to registered users of HySecurity products.

IMPORTANT SAFETY INFORMATION



Read all the product safety information prior to installation. Automatic gate operators move the gate with high force and can cause serious injury and death! Make sure the automatic gate operator is installed to reduce the risks of entrapment. Verify the gate operator is installed to comply with all safety standards and local and federal regulations.

Understand that you as the site designer, installer, maintenance crew, or owner/user must consider the risks associated with automatic gate operators. Hazards exist with automatic gate operators and can be reduced with proper gate site design, installation and use. Installers, maintenance crews, and owners/users must take responsibility to read and follow the safety requirements and Important Safety Information found in the HySecurity product manuals and review all the literature that accompanies the product.

It is important that only qualified installers handle the installation of the HySecurity equipment and gate operator. A "qualified" installer has one of the following:

- A minimum of three years experience installing similar equipment
- Proof of attending a HySecurity Technical Training seminar within the past three years
- Significant manufacturer endorsements of technical aptitude in automatic gate operator installation and operation

Underwriter Laboratories (UL) and the American Society for Testing and Materials (ASTM) are responsible for current safety standards and regulations regarding automatic vehicular gate operators. To pass certification, all aspects of gate operator and gate installation must comply with the appropriate safety standards.

For the most up-to-date ASTM F2200 Gate and Fence Standards, refer to www.astm.org.
For UL 325 Standard of Safety, refer to www.ul.com.

SAVE THESE INSTRUCTIONS

IMPORTANT SAFETY INFORMATION



A moving gate or barrier arm, bollard, or wedge can cause serious injury or death.

To reduce the risk of injury or death:

1. **READ AND FOLLOW ALL INSTRUCTIONS.** Read the gate operator's product manual and review all the product labels and literature prior to installing, operating, or maintaining the automatic gate operator.
2. Never let children operate or play with gate controls. Keep all remote controls, especially radio transmitters, away from children. Do not allow children to play on or around the gate or gate operators.
3. Always keep people and objects away from the gate. **NO ONE SHOULD CROSS THE PATH OF THE MOVING GATE.** Start the gate operator only when a gate's travel path is clear.
4. Test the gate operator monthly. The gate **MUST** reverse on contact with a rigid object or stop when an object activates the non-contact sensors. After adjusting the force or the limit of travel, retest the gate operator. Perform routine tests of the entrapment protection sensors, such as photo eyes and gate edges. Failure to adjust and retest the gate operator properly can increase the risk of injury or death.
5. Use the emergency release only when the gate is not moving.
6. **KEEP GATES PROPERLY MAINTAINED.** Read the product manuals. Have a qualified service person make repairs to gate hardware and replace batteries in accessory or entrapment sensory devices on a regular basis.
7. The automated gate entry is for vehicle use only. Pedestrians must use a separate entrance. Make sure a separate walk-through entrance is nearby. Make certain a clear pedestrian path is designated and signs direct pedestrians to the walk-through gate.
8. Install the supplied **WARNING** signs on the inside and outside of the gate or barrier gate/operator so they are clearly visible from both the secure and public sides. Installing the signs is a requirement for UL 325 compliance.
9. Use monitored sensors for protection against entrapment as specified in the current UL 325 Standard of Safety.

Safety - Additional Installer Responsibility

- The gate operator must be properly grounded and the incoming power voltage must match the voltage label on the junction box.
- Verify and install an automatic gate operator per its usage class and only on gate sites that comply with ASTM F2200 Gate and Fence Standards. See *Identifying Gate Operator Category and Usage Class* on page 5. Screen or enclose openings in the gate and install sensors to monitor potential entrapment areas per UL 325 Standard of Safety, which includes:
 - All horizontal slide gates must guard or screen openings from the gate's base support to a minimum height of 6 feet (183 cm) above the ground. This must prevent a sphere of 2¼ inches (57 mm) in diameter from passing through an opening in the gate or the adjacent fence that is covered in the gate's open position.
 - Physical stops must exist in the gate construction to prevent over-travel in both directions and, for slide gates, guard posts must be installed to prevent the gate from falling in the event of a roller failure. Exposed rollers must be capped to avoid potential entrapment.
 - Make sure all exposed pinch points are eliminated or any exposed pinch points, rollers and wheels are guarded.
- External entrapment protection sensors must be used wherever the risk of entrapment exists.

SAVE THESE INSTRUCTIONS

IDENTIFYING GATE OPERATOR CATEGORY AND USAGE CLASS

Gate operators are given a usage class according to UL 325 Standard of Safety. The usage class is determined by the area that the vehicular gate operator services.

Four different vehicular usage classes are defined by UL 325:

Class I



Class I: Intended for use in garages or parking areas associated with a residence of one to four single families.

Class II



Class II: Intended for use in a commercial location or building such as a multi-family housing unit (five or more single family units) hotels, garages, retail stores or other buildings accessible by or servicing the general public.

Class III



Class III: Intended for use in an industrial location or building such as a factory or loading dock area or other locations NOT accessible by or intended to service the general public.

Class IV



Class IV: Intended for use in a guarded industrial location or building such as an airport security area or other restricted access locations, **NOT** servicing the general public, in which unauthorized access is prevented via supervision by security personnel.

SAVE THESE INSTRUCTIONS

IMPORTANT SAFETY INFORMATION

Safety - Additional Installer's Responsibility, continued

- Before attaching the operator to the gate, move the gate or barrier gate in both directions. Make sure it is level and moves freely. A gate or barrier gate that moves easily reduces strain on operator components. Gravity should play no part in the opening or closing of a slide gate.
- Never over-tighten a clutch or pressure relief valve to compensate for a stiff or damaged gate.
- Reduce the risk of entrapment throughout the entire travel path by making sure the gate is installed in a location which ensures the required clearance between the gate and adjacent structures when opening or closing. On slide gates, minimize the parallel gap between the gate and the fence.
- Install the gate operator on the secure (non-public) side of the gate. **Note that swing gates cannot open into public areas.**
- Install external entrapment protection sensors so pedestrians are protected from entrapment in both directions of gate travel and all hazard areas are fully protected. On hydraulic gates, set the pressure relief valve at the lowest allowable setting that will reliably operate the gate. The pressure relief valve controls the applied force of the operator and the sensitivity of the inherent entrapment sensor (IES). Note that no IES exists in the StrongArm.
- Never disable the Warn Before Operate buzzer. This buzzer provides an alert that the gate is about to move.
- Mount access control devices beyond reach of the gate. The control devices that operate the gate must:
 - Be mounted beyond 6 feet (183 cm) of the gate to prevent users from touching or accessing the gate while operating the controls. People attempting to access the controls by reaching through or around the gate can be seriously injured or killed by the moving gate.
 - Incorporate a security feature to prevent unauthorized use.
 - Connect radio and other remote access (non-resetting controls) to the RADIO OPTIONS terminal.
 - Be located in a clear line of sight to the gate. Locate access controls (Open, Close, Stop/Reset) where a user will have a clear view of the gate.

NOTE: An exception for Emergency Access Control devices exists. An EAC device accessible by authorized personnel only (e.g. fire, police, EMS) may be placed at any location within the line-of-sight.
- Open and close the gate to confirm that it was properly installed and to ensure monitoring sensors are working correctly. Verify the clearance between the gate and adjacent structures per UL 325 Standard of Safety. Have a qualified technician test the gate monthly.
- When you complete the installation, demonstrate the safety features and operation of the gate operator to the end user:
 - Clearly explain and demonstrate the consequences of removing or defeating any of the safety features.
 - Remove the operator cover(s), and then turn the power on and off.
 - Manually release the gate. (Use the manual release only when the gate is NOT moving.)
 - Use the Emergency Stop Button. (If an emergency stop button is not available, show the user where the Stop button is located on the gate operator.)

NOTE: Gate operator instructions must be given to the owner per UL 325 Standard of Safety.
- Take photographs of the completed installation site and save it in your business files.

SAVE THESE INSTRUCTIONS

IMPORTANT SAFETY INFORMATION

Safety - Owner/User Responsibility

As the owner/user, you are responsible for the correct and safe installation, operation and maintenance of the SwingRiser gate operator. It is of the utmost importance that you read and follow the specific instructions and precautions found in the IMPORTANT SAFETY INFORMATION addressed in this manual. In addition, you must adhere to the safety standards of applicable federal, state, and local safety regulations, industry standards, and/or procedures.

NOTICE: For installations outside the United States, make sure that you follow the applicable international, regional, and local safety standards.

-
- Automatic gates are for vehicular use only; provide and maintain walkways and signs to direct pedestrians to a separate walk-through entrance.
 - An automatic gate can start at any time without warning; always keep people away from the gate area.
 - Never let children operate or play with gate controls. Keep all remote controls, especially radio transmitters, away from children. Do not allow children to play on or around the gate, gate area, or gate operators.
 - Learn how to turn the power on and off. Learn how to manually operate the gate.
 - WARNING signs supplied with the gate operator must remain installed and clearly visible on both sides of the gate. The signs are required to maintain UL 325 compliance.
 - Do not physically disable the warning buzzer and NEVER disconnect or cut its wires. The buzzer provides compliance with the Manual on Uniform Traffic Control Devices (MUTCD) standards. Disabling the warning buzzer may increase the risk of death or serious injury.
 - Do not remove entrapment protection sensors or any other safety features.
 - Have a professional gate installer routinely inspect the gate hardware and test the entrapment protection sensors and overall gate operation. Have a qualified service person make repairs to gate hardware and equipment to keep the gate running smoothly.

HAZARDOUS MATERIALS AND PROPER DISPOSAL

Be aware of the international, federal, and local codes in your area and how best to handle hazardous waste materials.

The pump pack fluid, found in all hydraulic HySecurity operators, can be recycled. Gear oil, found in HySecurity electromechanical gate operators, can also be recycled. If the fluids are mixed or contaminated with any solvents or other chemicals, they become hazardous waste. Hazardous waste requirements for storage and disposal must be followed.



If the gate operator has a battery backup system, the batteries contain materials that are considered hazardous to the environment. Proper disposal of the battery is required by federal law. In the U.S.A., refer to federal EPA guidelines for proper hazardous waste disposal.

SAVE THESE INSTRUCTIONS

BREATHER CAP INSTALLATION AND GROUNDING

The gate operator has a vent plug that keeps the hydraulic fluid from spilling during shipment. The vent plug must be replaced by the breather cap before operating the automatic gate operator.



Failure to perform the following procedure will cause premature pump shaft failure and void the HySecurity Warranty.

1. Remove the vent plug and discard it.
2. Replace the vent plug with the breather cap.

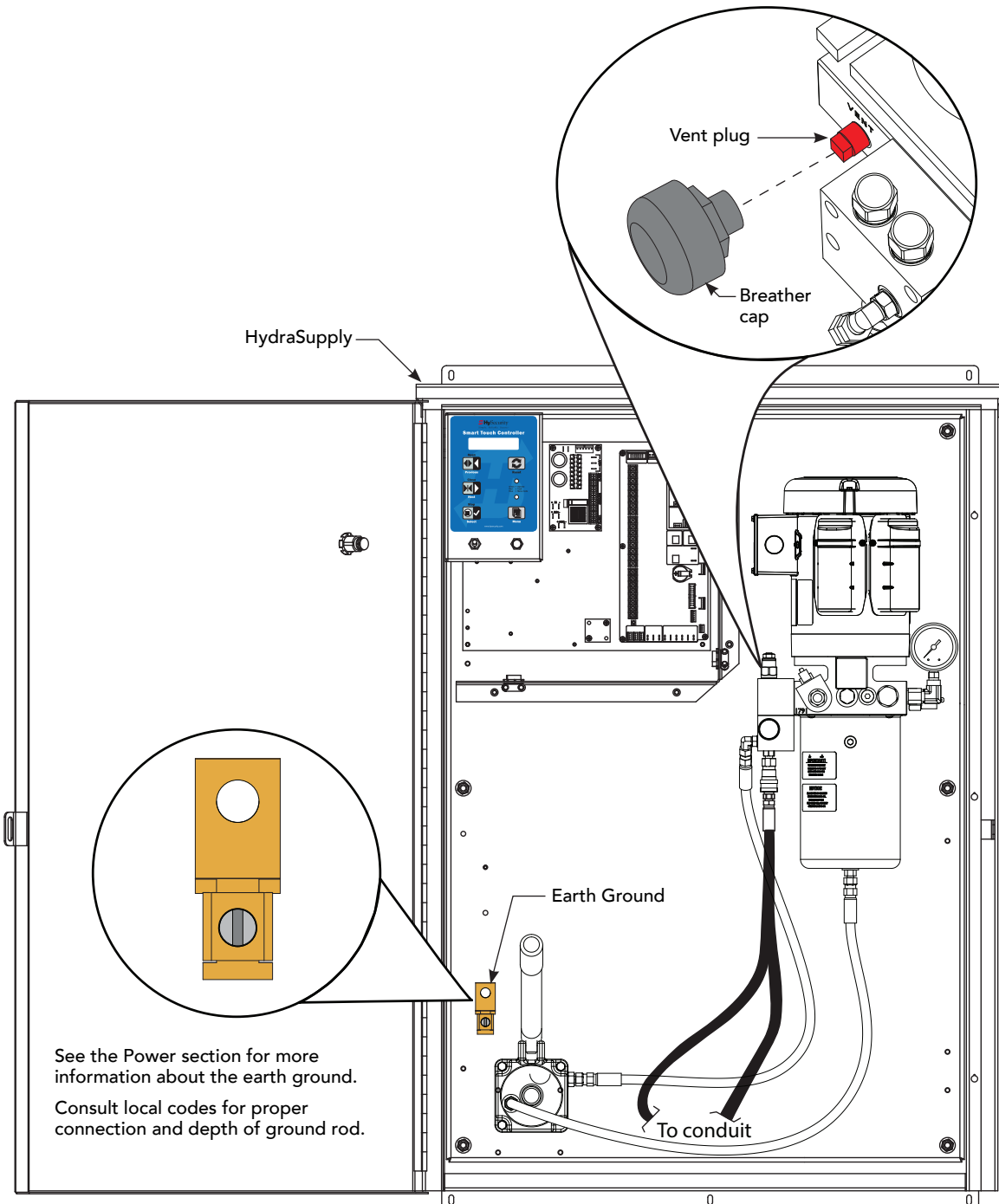

EMERGENCY STOP BUTTON

Make sure all users of the gate know where the emergency stop button is located (see illustration). It complies with UL 325 Standard of Safety requirements.

Pressing the emergency stop button while the gate is opening or closing disables the automatic close timer and stops gate travel. Gate travel remains stopped until the operator receives another open or close signal.

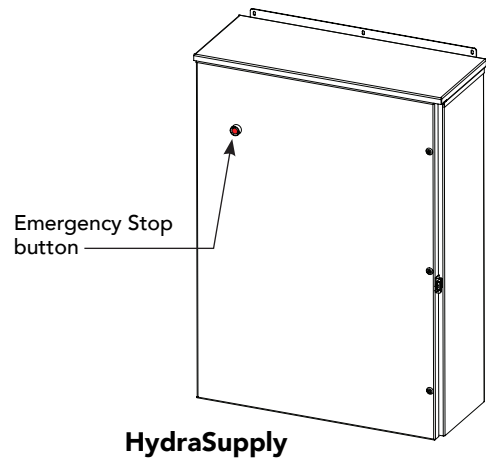

FLOW CONTROL VALVE – CLOSE DIRECTION

The valve restricts the hydraulic fluid flow back to the pump pack and affects the closing speed of the gate.

NOTE: Use the control valve to fine-tune the gate's closing speed. To affect closing speed adjustments on a broader scale, change the pump pack's size and the motor's horsepower.



Before adjusting the flow control valve, the SwingRiser posts must be installed, plumb, and wired to the HydraSupply. The gate must be secured on the posts with its index arm attached, adjusted, and tightened.

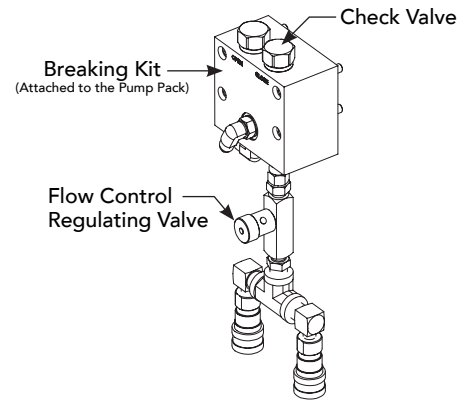

Two different methods exist for flow control adjustments. Older SwingRiser operators have color bands, newer operators do not. Instructions for handling both are found on page 106.

RELEASING THE GATE: MANUAL OPERATION

Two options exist for manual release of the gate depending on your site situation and needs:

- Option 1: Gate movement using its auxiliary hinges
- Option 2: Hydraulic movement of the cylinder to open or close the gate

Option 1: Release the Gate

1. Lift locking pin to free it from its receptacle.
2. Remove bolt or padlock from the index arm. The gate can now swing freely on its gate post hinges. Refer to index arm assembly on page 104.

Option 2: Open the Gate using the Hand Pump



Before attempting a manual release, make sure the gate is not in motion and power is disconnected (turned OFF).

In the event of a power failure, manual operation can be achieved by accessing the hydraulics cabinet. Follow the steps below to open or close the gate.

1. Open the HydraSupply cabinet.
2. Turn the power switch OFF.
3. Locate the knurled knob on the Open Valve.
4. Firmly, pull and twist the knurled knob counterclockwise. With a few threads showing, release the knob so that it remains in the open position.

NOTE: If the valve re-seats itself, repeat the pull and twist in the opposite direction until the valve remains open.

5. Insert the pump handle into its receptacle on the hand pump. Begin pumping the handle up and down. As hydraulic fluid is pumped into the cylinder, it begins to move the gate.
6. Continue pumping until the gate reaches full open position.
7. Turn the knurled knob so it springs back to the closed position. This keeps the fluid level stable.

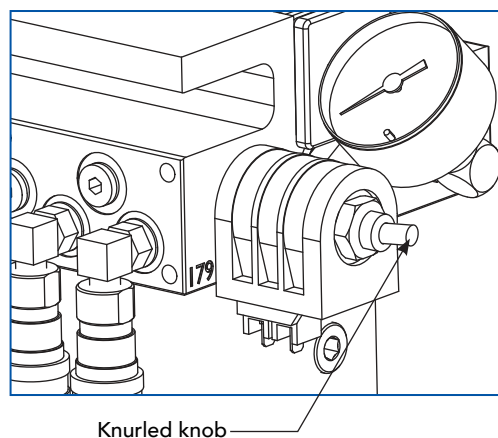

Option 2: Close the Gate using the Hand Pump

1. Check that the knurled knob is in the closed position. Begin pumping the handle up and down. The gate slowly closes with the pumping motion.
2. The gate will maintain its position whenever you stop pumping.
3. Continue pumping until the gate reaches the full closed position.
4. If locking pin exists, reset it to secure the gate.

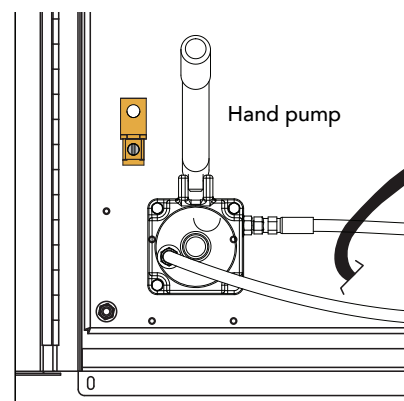

SwingRiser HRG 220

WIND LOAD CONSIDERATIONS

Wind load is always a factor when considering the appropriate gate for a particular site. The SwingRiser incorporates a primary Type-A inherent entrapment sensor (IES) into its design per UL 325 Safety Standards. When the IES trips, it sends a signal to the gate operator to stop and reverse direction. This feature may be falsely triggered in excessively windy conditions because the wind itself, acting over the surface area of the gate panel, can provide the necessary force to trigger the IES.

- Check gate operator specifications. If the gate is heavy and near the weight capacity of what the gate operator can handle, make sure the gate has an open design that allows wind to flow through it. A solid gate, under certain wind load conditions, may cause damage to the gate operator and is not covered by the HySecurity Warranty.
- Do NOT adjust the IES sensitivity to accommodate for inappropriately designed gate panels. Loss of IES sensitivity increases mechanical wear on the gate hardware and the gate operator. It may also pose a safety hazard.

NOTICE: Under certain wind load conditions, damage to the gate or gate operator may occur and is not covered by the HySecurity Warranty.

SAFETY NOTICES

The following four levels of safety notices are used where applicable within this manual; each notice contains information specific to the situation.



Indicates death or serious injury will occur if the hazardous situation is not avoided.



Indicates death or serious injury could occur if the hazardous situation is not avoided.



Indicates mild or moderate injury could occur if the hazardous situation is not avoided.

NOTICE: Indicates damage to equipment is probable if the hazardous situation is not avoided.

COMMON INDUSTRIAL SYMBOLS

The following international safety symbols may appear on the product or in its literature. The symbols are used to alert you to potential personal injury hazards. Obey all safety messages that follow these symbols to avoid possible injury or death.

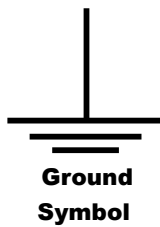
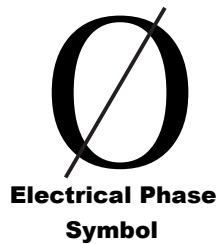

How to wire the operator is presented in the *Installation Instructions*, but detailed information about the earth and equipment ground, wiring to AC power and the availability of UPS systems are described in this section.

[Supplemental documents](#) to this section include:

- DC Power Supply with HyCharger DC
- AC Power Supply with HyInverter AC

INSTALLING THE EARTH GROUND

An earth ground refers to the grounding rod and accompanying equipment ground which need to be installed to safeguard against potential electrical shock and damage to personnel and equipment.



The potential for lightning discharge exists with all gates, fences and gate operators. National Electric Code (NEC) - Article 250 requires a separate earth ground in addition to the required equipment ground.

HySecurity recommends grounding the operator with a separate earth ground rod (or a similar device in the case of crash products) to shield the operator against electromagnetism and other electrical signals that may cause, erratic operation with, or damage to, the Smart Touch Controller and other electrical parts.

For earth grounding requirements in the U.S.A., refer to the National Fire Protection Association (NFPA) 780 - Standard for the Installation of Lightning Protection Systems. Highlights of the standard include:

- The ground rod must be UL listed copper-clad steel, solid copper, hot-dipped galvanized steel, or stainless steel. Minimum requirements: $\frac{5}{8}$ inch (16 mm) diameter and 8 feet (244 cm) in length.
- The ground rod is driven into the earth (refer to local codes for proper depth requirements).
- The ground rod is electrically bonded to the chassis with a single length of un-spliced 6 AWG copper wire less than 3 feet (91 cm) long. Due to the large concrete foundation on crash products, make the necessary adjustments to accommodate for earth ground requirements.
- Local jurisdictions may impose other requirements above the NEC, Article 250 and NFPA 780. Consult the local codes and regulations regarding requirements in your area.

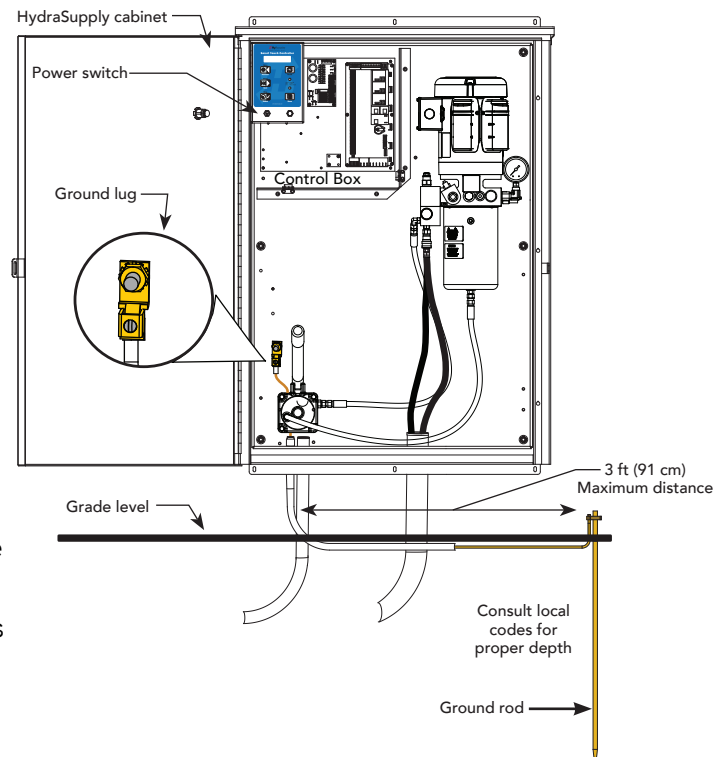

NOTICE: Properly grounding the gate operator is critical to gate operator performance and the life of its electrical components. Use sufficient wire size during installation. If you do not ground the operator with a separate earth ground, you risk voiding the HySecurity Warranty.

Site Considerations

HySecurity gate operators are intended for permanent installation. Make sure you prepare the site with the following considerations:

- Make sure all electrical wiring is properly routed via conduits.
- Check the distance of the wiring run from the main panel to the gate operator. Make sure the wire size of the branch circuit supplying power to the gate operator is large enough to avoid excess voltage drop. Refer to *Wire Sizing and Runs on page 17*.
- Make sure the available power source matches the electrical requirements specified on the voltage nameplate.



Each gate operator is built to run on a specific line power voltage and phase. Failure to ensure the source voltage (phase and frequency match what is specified for the equipment), may result in severe damage to the equipment.

-
- Make sure a 20-amp circuit (minimum) protected with a 20-amp Inverse Time Breaker is provided for all AC power connections.
 - Verify that the operator is electrically grounded per NFPA 780 and NEC Article 250 and local codes.

WIRING AC POWER

The SwingRiser has separate *Installation Instructions* that explain how to connect to AC power. For reference purposes, the same information is provided below.

In-rush Current is the current needed to start the electric motor spinning in the proper direction (CCW). It may take as much as 6 to 9 times the in-rush current to start one of the heavy duty operators.

NOTE: Use a 20A (minimum) slow kick (thermal) circuit breaker for all AC motors.

Size the primary wires. Consider the voltage, horsepower, and length of the wire run from the main power panel.

Make sure you have the proper voltage and conversion of voltage taps at the motor and transformer.



Turn OFF AC power at the source (circuit breaker panel) before accessing the wires in the SwingRiser. Follow facility Lock Out/Tag Out procedures. Make sure all power switches are in the OFF position. Follow all electrical code standards and regulations.

1. **Connect to Power:** Two pig tails and a ground are available for connection to a 1 Phase power source (1Ø) on the back of the keypad display enclosure.
2. **Connect AC Power:** Wire nut the incoming power wires to their appropriate pig tails. Attach the ground wire to the chassis. A wiring diagram is provided in the appendix.

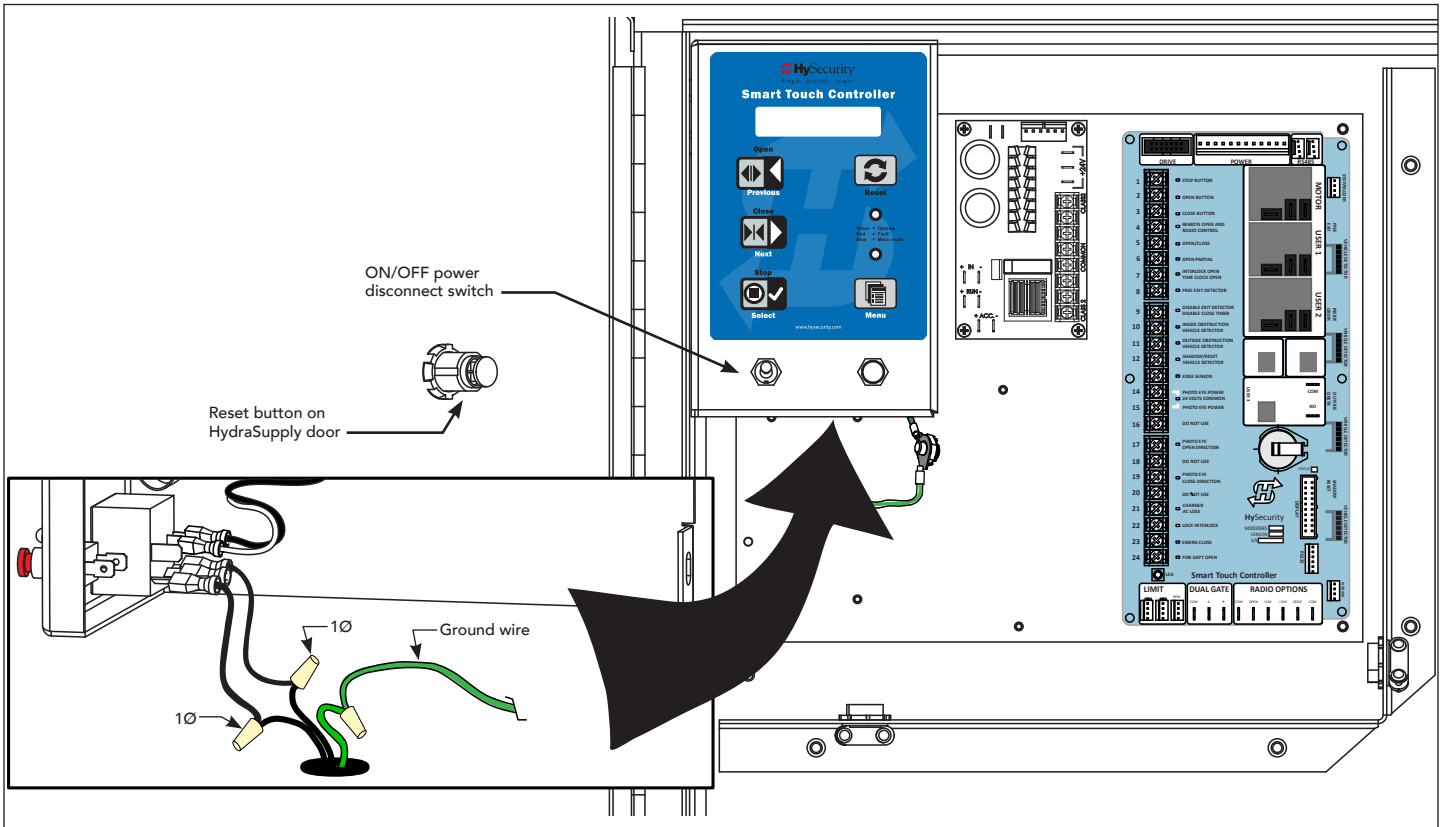

Wiring of gate operators must conform to NFPA and NEC standards and comply with all local codes. When the installation is compliant and complete, turn on AC power at the source and at the control box.

Turning the Power Switch ON

The AC power disconnect switch is located on the same enclosure (control box) where the electrical components, Smart Touch Controller, transformer, power supply board, etc., are found.

When power is turned ON, a green status light on the Smart Touch Controller blinks. The status light appears below the coin battery and indicates that the processor is receiving power. For more information, refer to *Understanding the Display and Keypad* on page 33.

Green LED flashes indicating processor is receiving power.

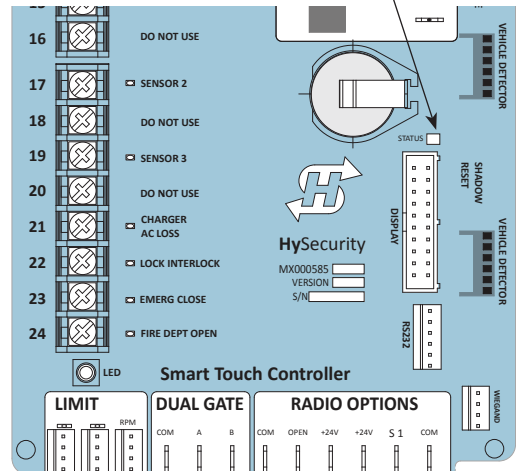

WIRING DIAGRAM: SMART TOUCH CONTROLLER SYSTEM

NOTE: IES leads are jumpered on all HTG (Hydraulic Traffic Gate, StrongArm models). HTG models do not have an IES sensor.

Right two terminal represent DC power output to Smart Touch board.

DC voltage between 22 and 32 volts

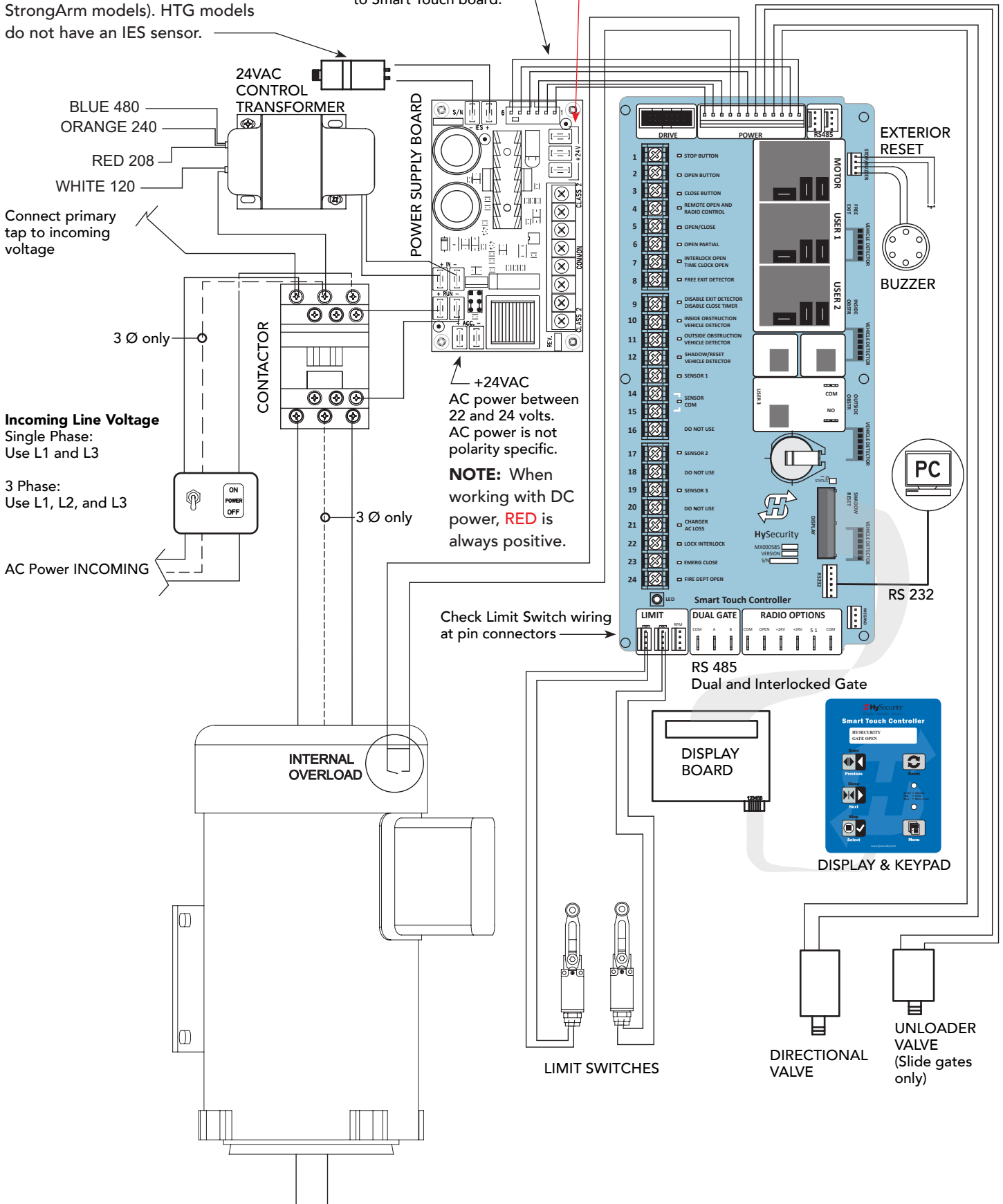

WIRE SIZING AND RUNS

Supplying a gate operator with the correct electrical service is crucial to the performance of the operator and the life of its electrical components. If the wire size used is too small, the voltage loss, especially during motor startup, will prevent the motor from attaining its rated horsepower. The percentage of horsepower lost is far greater than the percentage of voltage loss.

A voltage loss can also cause the control components to chatter while the motor is starting, substantially reducing their life due to the resultant arcing. There is no way to restore lost performance resulting from undersized wires, except to replace them. To avoid costly rewiring, be sure to choose a sufficient wire size during site planning phases and at initial installation.

The tables on the following page are based on copper wire and allow for a 5% voltage drop. The ampere values shown are the service factor ampere rating of the motor (maximum full load at continuous duty). At minimum, a 20A circuit (protected with a 20A Inverse Time Breaker) should be provided.

Always connect electrical power and ground the operator in accordance with the NFPA 780 & NEC, Article 430 and Article 250. Research and adhere to other local codes that may apply.

Low Voltage Control Wiring

The Smart Touch Controller has very sensitive control inputs. The following is a chart of maximum distances for wire size:

Wire Size	Maximum Distance
18 ga	7.0 miles (11 km)
20 ga	3.5 miles (5.6 km)
22 ga	2.7 miles (4.3 km)
24 ga	2.0 miles (3.2 km)
26 ga	1.0 mile (1.6 km)
28 ga	3700 feet (1.1 km)

SwingRiser Wiring Charts (Incoming Power)

The maximum distance, shown in the chart below, reflects the distance from the operator to the power source, assuming that source power is from a panel box with adequate capacity to support the addition of this motor load. The values are for one operator, with no other loads applied to the branch circuit. Avoid placing more than one operator to a circuit, but if you must, be certain to reduce the maximum allowed wire distance by half.

NOTE: Distance shown in U.S. Standard "feet." Metric equivalent shown in parentheses.

SwingRiser Wire Size Chart						
	115V Single Phase		208V Single Phase		230V Single Phase	
Horsepower	1	2	1	2	1	2
Amps	14.4	27.2	7.6	14.2	7.2	13.6
Wire Gauge	Distance	Distance	Distance	Distance	Distance	Distance
12	60 (18m)	30 (9m)	205 (62m)	110 (33m)	245 (75m)	130 (40m)
10	100 (30m)	50 (15m)	330 (101m)	175 (53m)	385 (117m)	205 (62m)
8	155 (47m)	80 (24m)	525 (160m)	280 (85m)	610 (186m)	325 (99m)
6	245 (75m)	130 (40m)	835 (254m)	445 (135m)	975 (297m)	515 (157m)
4	385 (117m)	205 (62m)	1320 (402m)	710 (216m)	1550 (472m)	815 (248m)
2	620 (189m)	330 (101m)	2110 (643m)	1130 (344m)	2465 (751m)	1305 (398m)

SwingRiser Wire Size Chart						
	208V Three Phase		230 Three Phase		460V Three Phase	
Horsepower	1	2	1	2	1	2
Amps	4.2	6.5	3.8	6.2	1.9	3.1
Wire Gauge	Distance	Distance	Distance	Distance	Distance	Distance
12	375 (114m)	245 (75m)	460 (140m)	280 (85m)	1850 (564m)	1130 (344m)
10	600 (183m)	390 (119m)	730 (222m)	450 (137m)	2930 (893m)	1800 (549m)
8	950 (289m)	615 (187m)	1160 (353m)	710 (216m)	4650 (1417m)	2840 (866m)
6	1510 (460m)	975 (297m)	1845 (562m)	1130 (344m)	7400 (2255m)	4550 (1387m)
4	2390 (728m)	1545 (471m)	2920 (890m)	1790 (546m)	11700 (3566m)	7200 (2194m)

UPS BACKUP POWER OPTIONS

If you plan to use back up power options, additional site considerations are needed including conduit to house the hydraulic hoses and electrical wiring. You need a 2-inch (5 cm) diameter conduit for hydraulic hoses and a ¾-inch (19 mm) conduit for electrical wiring. Mounting locations such as pad mount or wall mount also need to be determined. See site planning overview in the installation instructions.

[Supplemental manuals](#), available online, describe the installation overview, wiring and conduit considerations.

DC Power Supply (UPS) Connections

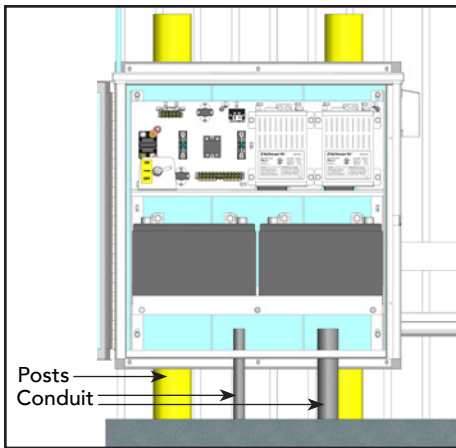

If you have a gate operator with a DC Power Supply unit, you will need to connect the primary AC input power to the DC Power Supply.

Additional ¾-inch (19 mm) conduit is needed for electrical wiring interconnections between the gate operator and DC Power Supply Cabinet. AC input power is connected to the electrical components in the chassis, and additional wiring is run through conduit to the DC Power Supply Cabinet.

System features are covered in the DC Power Supply with HyCharger DC supplement shipped with the product and available online.

AC Power Supply with HyInverter AC

Gate operators equipped with the AC Power Supply with HyInverter AC option are powered by four 12-Volt, 110Ah DC batteries which, when AC power loss occurs, maintain a true Uninterrupted Power Supply (UPS) system. When the local AC power fails, the UPS back up system continues to move the gate. System features are covered in the *HyInverterAC Installation and Reference Manual* shipped with the product and available online.

NOTICE: The AC Power Supply with HyInverter AC option is intended for single phase (1 hp) gate operators and single phase (2 hp) gate operators that use Variable Speed Drives (VFD).

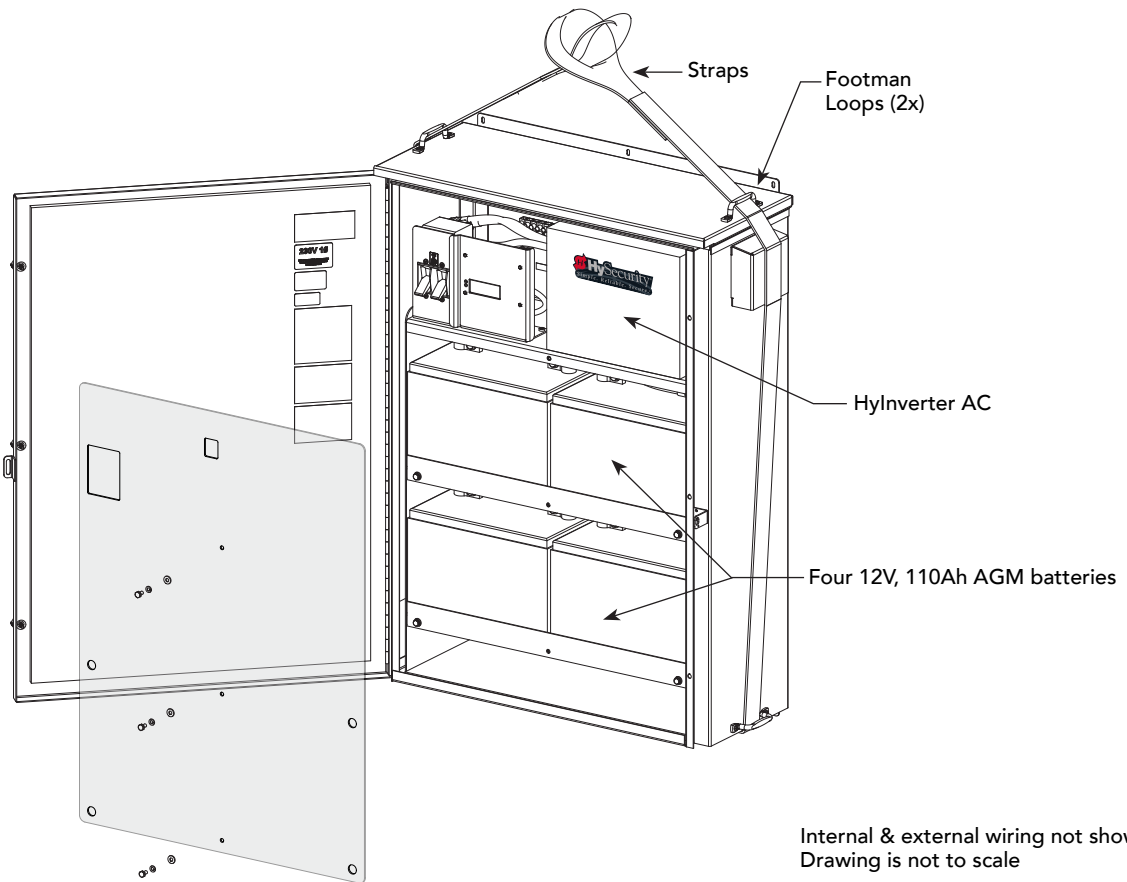

Initial Setup

When you first apply power to the gate operator, it is locked in Menu mode and prompts appear on the display. The gate will not move and the controls will not function until the prompts have been answered. The prompts include:

- Usage Class setting
- Three external entrapment protection SENSOR assignments



Before turning the power switch to ON, be sure to replace the vent cap with the breather cap. See page 8. Make sure all site requirements concerning proper wiring, safety, foundation installation, and electrical power have been met.

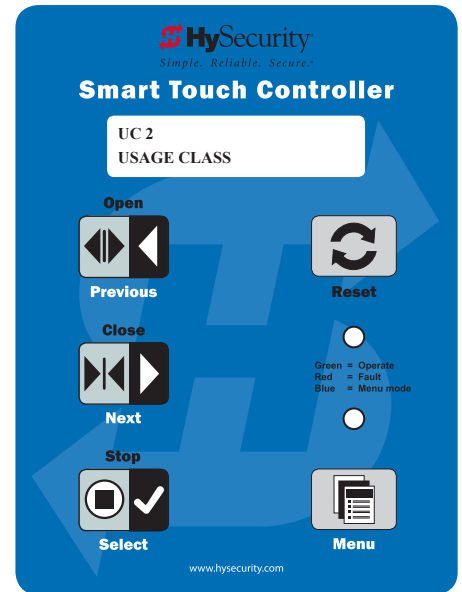

Five buttons on the display keypad provide operational controls. Refer to *Display & Menu Options* on page 33 for more information. To answer the initial prompts, use the Previous, Next, and Select buttons as described in the chart below:

Smart Touch Controller: Menu Mode Navigation Buttons

To change that data appearing in the display	To navigate through the Selections	To choose what appears on the display	To navigate between menu items
Press Select . Two left characters blink.	Press Next . Continue pressing Next to view all selections. (Press Previous to reverse direction.)	Press Select . Blinking characters become static.	Press Next or Previous . Advance - press Next Previous - press Previous

If you are unsure of the usage classification, refer to *Identifying Gate Operator Category and Usage Class* on page 5. It explains the different usage site classifications for UL 325.

SWINGRISER ORDER FORM

Gate speed, direction of swing, and degree of swing are fixed and cannot be changed in the field. Be sure to read and fill out the [SwingRiser Order Form](#) based on your site configuration. It walks you through all aspects, from outer and inner post heights, to top cap brackets, voltage requirements, direction & degree of swing and hose length considerations.

For more information, download the order forms by clicking on Technical Support from the [HySecurity website](#).

GATE HANDING

Gate handing is determined by standing on the secure side of the gate and looking out toward the public side. See illustration.

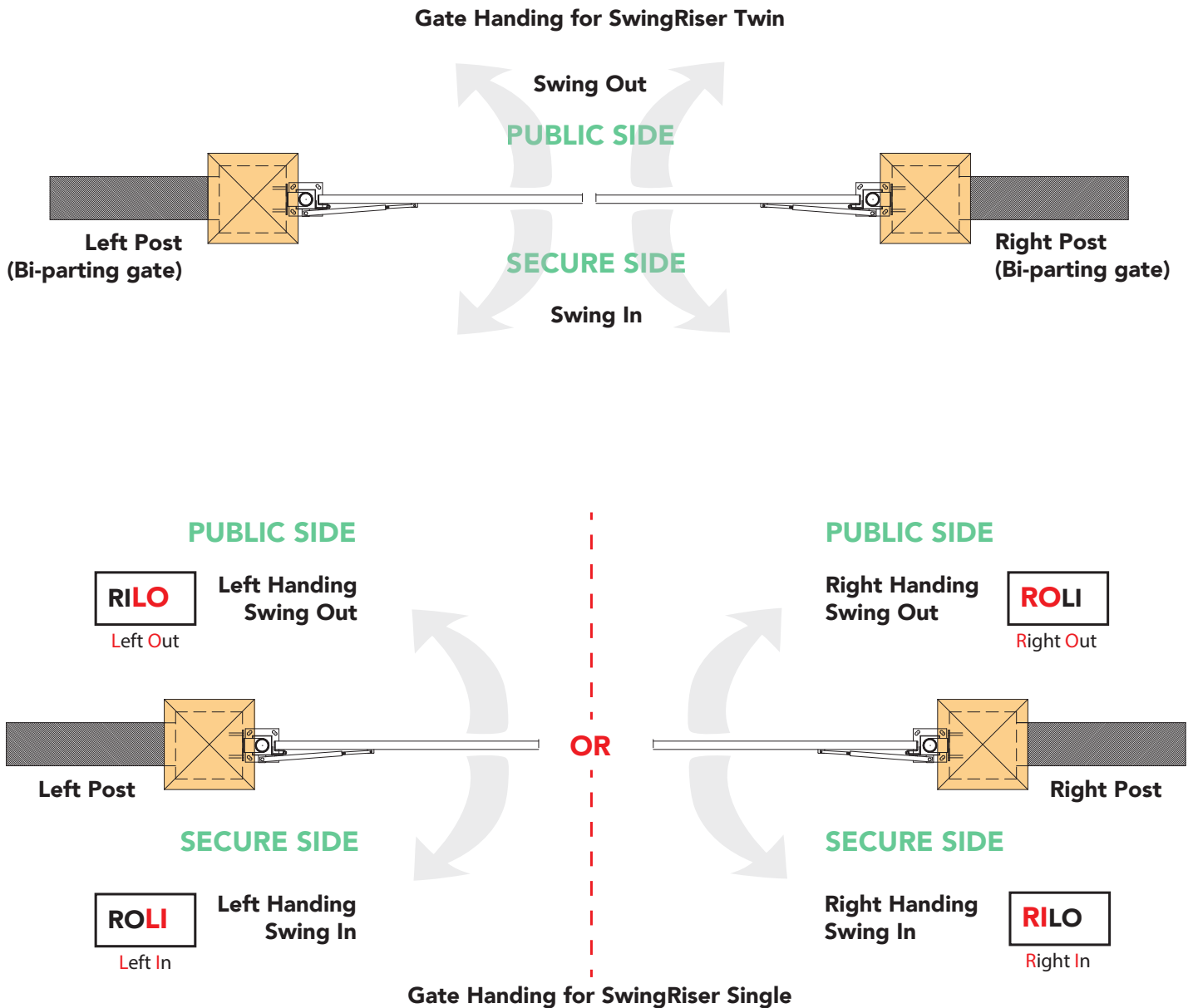

ADJUSTING THE PRESSURE RELIEF VALVE

When placing the operator into service, pressure relief valve adjustments are required! To provide instruction during installation, a cautionary yellow tag is wire tied to every pump pack. The same instructions are provided in this section.

Pressure relief valves differ depending on the model.

Tools Needed: ½" and ⅝" box end wrenches.

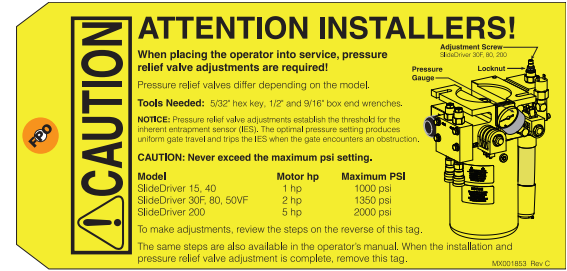

NOTICE: Pressure relief valve adjustments establish the threshold for the inherent entrapment sensor (IES). The optimal pressure setting produces uniform gate travel and trips the IES when the gate encounters an obstruction.

Model #	Model	Gallons per minute	Motor hp	Maximum PSI*
1	SwingRiser HRG 220	3.1	1 hp	2000 psi
2	SwingRiser HRG 222	4.0	2 hp	2000 psi



* Look at the pressure gauge while the gate is traveling open or close. Note maximum pressure while the gate is in motion and write it down. Never exceed 200 psi above that maximum pressure reading.



DO NOT attempt to adjust the pressure relief valve unless you are an experienced hydraulic gate operator installer. Incorrect pressure settings can cause injury and even death!

Make sure the gate is properly installed and aligned before performing the following steps. Take precautionary measures to keep the gate's travel path clear. The gate will be moving while you adjust the pressure relief valve.

1. Expose several threads on the Pressure Relief Valve by loosening the locknut with a ⅝" box end wrench.
2. Use a ½" box end wrench to turn the adjustment screw.
3. Use the keypad to cycle the gate Open or Close and, while the motor is running, turn the adjustment screw clockwise (CW) to raise the pressure. The motor runs for a few seconds, stops, and then enters safe mode. SAFE appears on the display.
4. Press Reset and repeat step 3 until gate travel is reliably consistent without entering SAFE mode.
5. To lock in the pressure setting, hold the adjustment screw with a wrench and tighten the locknut.

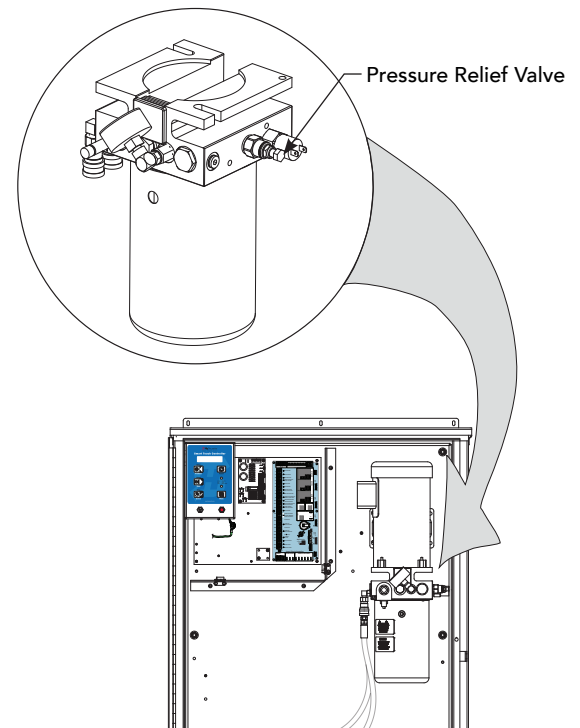

ADJUSTING THE GATE SPEED

SwingRiser gate operators employ the use of a flow control valve to allow slight adjustments in the closing speed of the gate. The flow control valve is the small rectangular brass device with the knurled adjusting knob, located just above the hydraulic hose quick-disconnect.

For more information on how to adjust the flow control valve, refer to *Adjustment of the Flow Control Valve without Color Bands* or *Adjustment of the Flow Control Valve with Color Bands* on page 107.

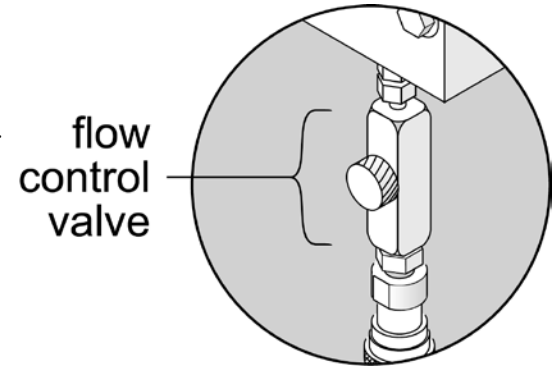

INSTALLATION OVERVIEW

Review the material provided in *SwingRiser Installation Drawings* on page 119.

Areas that may require adjustment beyond what is discussed in this section, include:

- Limit switches (*SwingRiser Posts & Installation Reference* on page 122)
- Index arm (*SwingRiser Index Arm Assembly* on page 104)
- Locking mechanism (*SwingRiser: Post Mount Locking Pin Installation* on page 127)
- Flow valve (*Adjusting the Flow Control Valve* on page 106)

Entrapment Protection

Effective January 12th, 2016 UL 325 Standard of Safety requires all automated gate operators be able to monitor for entrapment protection sensors. Before gate movement occurs, the UL 325 compliant HySecurity gate operator verifies that the external entrapment protection sensors are connected and fully functional.

The site designer or installer must determine which external entrapment protection sensors will be installed with the gate operator to create a UL 325 compliant installation site.

The following bullet points highlight how your automated gate system sites can monitor sensors (external entrapment protection sensors) using HySecurity gate operators:

- **Normally Closed (NC) sensors** - Installing Normally Closed output sensors. External entrapment protection NC sensors are “monitored” by HySecurity gate operator software.
- **Build Year (BY)** - An added menu item distinguishes between pre-2016 manufacturing dates and UL 325 - 2016 manufacturing dates. Build Year (BY) is a factory-setting. Build Year 2 (BY 2) is the default for all HySecurity gate operators indicating a manufacturing date of 2016 in the serial number. Replacement controller boards for existing sites allow for a Build Year setting of 1 (BY 1, pre-2016).
- **Independent Sensor Inputs** - The edge, photo eye and photo eye COM inputs on the Smart Touch Controller (STC) have been re-labeled. The same wiring connections become three independent methods for easy entrapment sensor configuration and normally closed outputs.

NOTICE: To enable fully automatic operation, the gate operator requires a MINIMUM of one external entrapment protection sensor to monitor potential entrapment zones in either the open or close direction of travel.

MANUFACTURER’S RESPONSIBILITY

- Build into the gate operator a means of detecting an obstruction or an inherent entrapment detection sensor
- Monitor input from external entrapment detection sensors
- Provide warning signs and an installation manual which, if followed, will result in a UL 325 compliant installation

Pressure Relief Valve – All Hydraulic Operators:

- Limits hydraulic system pressure
- Bypasses fluid to tank when set-point exceeded
- Bypassed fluid triggers the IES

NOTICE: Pressure relief valve adjustments establish the threshold for the Inherent Entrapment Sensor (IES). The optimal pressure setting produces uniform gate travel and trips the IES when the gate encounters an obstruction.

Inherent Entrapment Sensor System – Hydraulic Operators (IES)

The IES sensor:

- Is a normally closed pressure switch on the pump manifold
- Senses fluid flow. High pressure spikes above pressure relief valve setting trigger gate obstruction notification
- Ignores first second of operation to preclude false trips due to starting pressure spike

An open contact:

- During gate movement signals the Smart Touch Controller to place gate operator into SAFE mode
- While the gate is not operating will generate ERROR 2 (ERR2) - disconnected IES

NOTE: A second open contact, in either direction of travel, will lock the gate operator and ENTRAPMENT MODE (ENTR) appears on the display.

THE INHERENT ENTRAPMENT SENSOR (IES)

The IES on HySecurity gate operators is an entrapment sensor that is required by UL 325 as a Type “A” detection sensor. It is tripped through software programming OR hydraulic pressure settings. It does not function solely on its own accord and must be connected to the Smart Touch Controller. The sensitivity and response of the IES when tripped is factory set, but can be adjusted through the Installer Menu items:

- SE (Inherent Sensor sensitivity)
- SS (Inherent Sensor function)
- SR (IES reverse to open)

Smart Touch Controller™ – Installer Menu Functions for IES		
Installer Menu Display Code	Setting Options (Bold – Factory Settings)	Description
SE 2 IES SENSITIVITY	1 = max. sensitivity 2 = Default setting 9 = least sensitivity	Adjusts the sensitivity of the internal inherent entrapment sensor (IES). Available settings are 1 to 9 with 9 being the least sensitive. HySecurity strongly recommends that you avoid setting the IES sensitivity higher than 6. Note: Adjust pressure relief valve on hydraulic operators for security and gate impact purposes prior to changing IES sensitivity. Refer to the operator’s manual for steps involved in adjusting the pressure relief valve setting.
SS 0 (OFF) IES STOP ONLY	0 = stop, reverse for 2s 1 = stop only	A setting of 0, stops the gate and then reverses its direction of travel for 2 seconds. To stop gate travel with no reversal, the optional setting 1 can be selected if the gate operator is at a Usage Class IV site and assigned a UC 4 classification.
SR 0 (FULL OPEN) REVERSAL LOGIC	0 = IES reverses fully open 1 = Two second reversal only	Setting of SR 0 causes the gate to reopen fully if triggered while closing. With a setting of 1, if the inherent sensor is triggered, the default setting reverses the gate travel for a 2-second duration.

HOW SOFTWARE HANDLES MONITORING EXTERNAL ENTRAPMENT PROTECTION SENSORS

HySecurity gate operators use software to control gate movement, contacts, and accessories. The changeover in 2016 to monitoring sensors has been a simple process.

- Build Year is a new Installer Menu item in the Smart Touch Controllers versions h4.50 (and higher).
- New labels show where Edge, Photo Eye Open and Photo Eye Closed have changed to “SENSOR” inputs. You can program the type of sensor wired to one of those inputs. See table below.
- Installer Menu items, PC and GC (Photo eye output and edge sensor output) which used to default to Normally Open (NO) have been converted to Normally Closed (NC) contacts so the software can detect the presence and proper operation of external entrapment protection sensors.

Table 3: Changes to Sensor Inputs on the Controller

Location of Sensor Inputs on Controller			Installer Menu Item Codes	
Smart Touch Controller (STC): Hydraulic gate operators			Smart Touch Display:	
Input #	Current Silk Screen Label	2016 Silk Screen Label	OLED - two line, 32 character	LCD - 7 segment text
13	EDGE SENSOR	SENSOR 1	S1 SENSOR 1	5 1
17	PHOTO EYE OPEN DIRECTION	SENSOR 2	S2 SENSOR 2	52
19	PHOTO EYE CLOSE DIRECTION	SENSOR 3	S3 SENSOR 3	53

NOTE: Three inputs for external entrapment protection sensors are available on the HySecurity gate operator controller. New silk screen controller boards are on order, but until they are ready for shipment, labels will be overlaid on the board to indicate terminology adaptations.

Table 3 indicates how the edge and photo eye inputs have been renamed to generic “sensor” inputs. They are interchangeable and configurable. The software must know what type of sensor is wired to SENSOR 1, 2, and 3 **BEFORE** it will allow gate travel.

EXTERNAL ENTRAPMENT PROTECTION SENSORS: WHAT THE INSTALLER NEEDS TO DO

NOTE: All HySecurity gate operators, indicating a manufacturing date of 2016 in the serial number, will have the Build Year set to 2. A Build Year of 2 (BY 2) indicates that your gate operator is prepared to monitor for external entrapment protection sensors. The Build Year setting appears in the system scroll on the gate operator display. **The gate operator will not automatically cycle the gate unless an indication that the appropriate number of external entrapment protection sensors are connected and operational.**

The normally closed (NC) entrapment protection sensors wired to the Controller’s SENSOR inputs are monitored using HySecurity software. Prompts appear in the display requesting specific configurations based on the gate operator type.

Table 4: *Installer Menu Settings for SENSOR Inputs* illustrates what options are available for the HySecurity Controller’s configurable inputs. Inputs labeling changed to:

SENSOR 1 SENSOR 2 SENSOR 3 SENSOR COM

Refer to illustration on page 32.



All external entrapment protection sensors must be wired to the SENSOR COM terminal for power and monitoring purposes. The sensor becomes actively powered when the gate operator receives a run command. The three SENSOR inputs are interchangeable and configurable. For example, it doesn't matter whether you wire a normally closed photo eye sensor or edge sensor to the SENSOR 1, 2, or 3 input. However, due to monitoring requirements, each SENSOR input (1, 2, and 3) can only accept one NC sensor output connection.

1 Assess Your Gate Site.

Design your gate installation so entrapment zones are kept to a minimum, and then install your HySecurity gate operator.

NOTICE: UL 325 Standard of Safety provides the MINIMUM safety standards. Site, gate hardware usage, and other conditions may dictate the use of additional safety designs/components. It is up to the gate system designer and installer to assess appropriate safety design and components above and beyond minimum UL 325 and ASTM F2200 standards. Always check your local area codes and comply with all regulations.

Swing Gates:

Potential Zones requiring Entrapment Protection

1. Leading Edge
2. Bottom Edge
3. Entry / Exit
4. Posts
5. Post Pivot / Pinch Points
6. Arm Movement

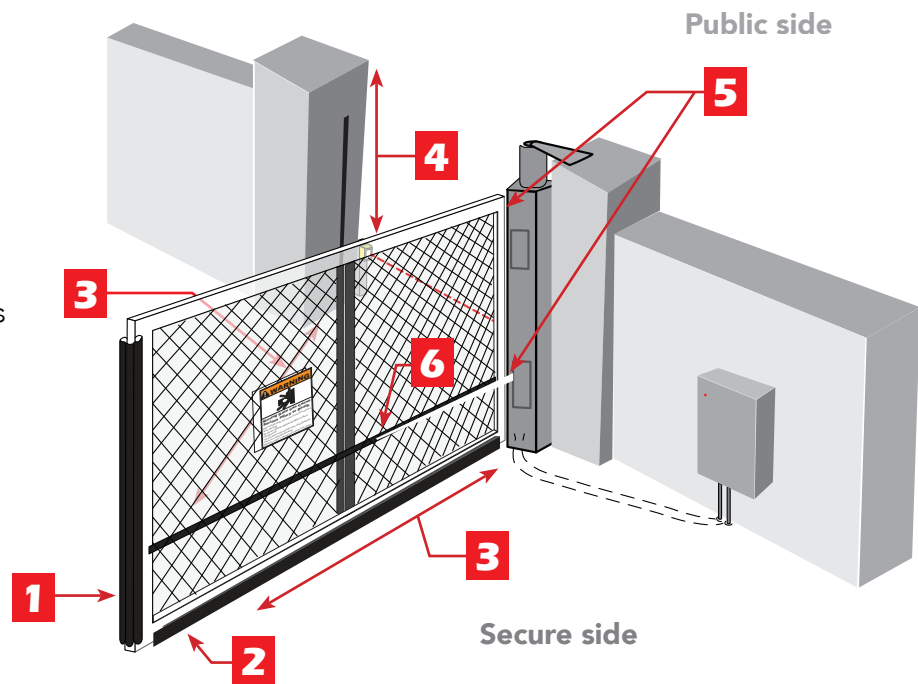

Drawing NOT TO SCALE

2 Install NC sensors.

Install contact and non-contact sensors (edge sensors and photo eyes) for all entrapment zones. HySecurity gates monitor normally closed (NC) sensors. Wire your NC sensors to SENSOR input terminals (SENSOR 1, SENSOR 2, or SENSOR 3) on the Smart Touch Controller.

NOTE: When installing wired edge sensors, the WIRED EDGE must be connected to an interface module that produces an NC output. Refer to *Wiring HySecurity Sensors: Smart Touch* on page 109. However, *wireless edge sensors*, require no interface module. Wireless edge sensors need the wireless gate links which include a transmitter and receiver.

3 Turn Power ON.

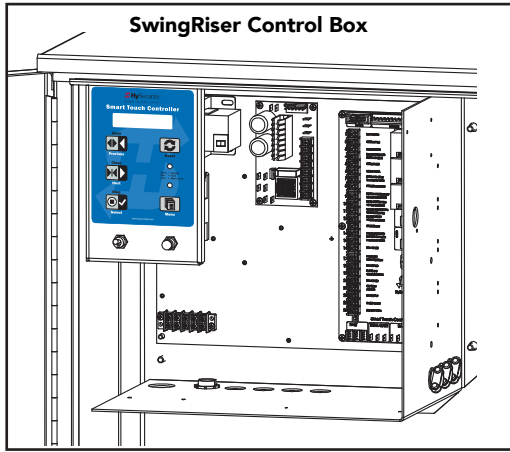

NOTE: On the next page, review LED function and how to provide temporary power to the sensors.

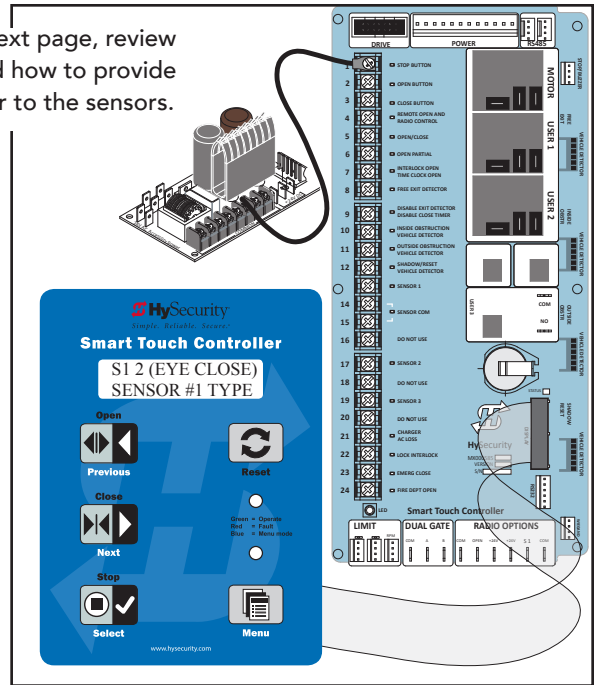

4 Answer Initial Setup Prompts.

For slide gates you will be prompted for USAGE CLASS, GATE HANDING, and SENSOR 1, SENSOR 2, and SENSOR 3. Each SENSOR input, whether or not it has a contact or non-contact sensor wired to it, must be programmed to a non-zero setting before the gate will move.

NOTE: The gate operator will not automatically cycle unless an indication is received that the appropriate number of external entrapment protection sensors are connected and operational. At minimum, external entrapment protection sensors must be used to protect both open and close directions of gate travel.

Smart Touch and Smart DC Controller: Menu Mode Navigation Buttons

To change data appearing in the display	To navigate through the Selections	To choose what appears on the display	To navigate between menu items
Press Select . Two left characters blink.	Press Next or Previous . Continue pressing Next to view all selections.	Press Select . Blinking characters become static.	Press Next or Previous . Advance - press Next Previous - press Previous

Table 4: Installer Menu Settings for SENSOR Inputs

UL 325 HySecurity Gate Operator	Build Year 2016 (BY set)	Installer Menu Settings for STC & SDC Sensors 1, 2, or 3 (solo operators)							
		#0 DISABLED	#1 NOT USED	#2 EYE CLOSE	#3 EDGE CLOSE	#4 EYE OPEN	#5 EDGE OPEN	#6 EDGE BOTH DIRECTIONS	#7 EYE BOTH DIRECTIONS
SlideDriver (fixed speed)	2	●	●	●	●	●	●		●
SlideDriver VFD	2	●	●	●	●	●	●		●
SlideSmart DC 15	2	●	●	●	●	●	●		●
SlideSmart DC 10	2	●	●	●	●	●	●		●
SwingRiser	2	●	●	●	●	●	●	●	
SwingSmart DC	2	●	●	●	●	●	●	●	
HydraSwing	2	●	●	●	●	●	●	●	
HydraLift	2	●	●	●					

NOTE: HySecurity does not update software for SlideWinder models. For information regarding HySecurity gate operators not shown in the table above, refer to Table 2: HySecurity Gate Operators maintaining Object Detection on page ii.

SUPPLY POWER TO THE SENSORS



All external entrapment protection sensors must be wired to the SENSOR COM terminal for monitoring purposes.



Review sensor wiring diagrams found in *Wiring HySecurity Sensors: Smart Touch* on page 109.

Until the gate operator receives a command to run (open or close command), the sensors are not receiving power. However, to **temporarily** power sensors and check that the gate operator is monitoring the sensors properly, turn on Photo Eye Align mode.

To turn on Photo Eye Align mode, take the following steps:

1. Access the User Menu and select PE. (Press the Menu button twice to access the User Menu. See chart on the previous page.)
2. Press NEXT and continue to press NEXT until PE 0 (OFF) appears.
3. Press SELECT.
PE characters begin blinking.
4. To turn ON photo eye alignment and temporarily power the sensors, press NEXT so PE 1 (ON) appears.
5. Press SELECT.
PE stops blinking.
6. Press MENU to exit Menu Mode and return to Run Mode.

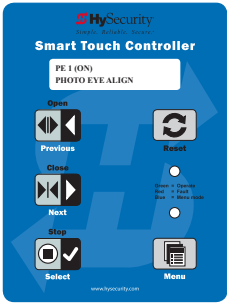
NOTE: The Photo Eye Align mode turns OFF with the next limit contact. For more information, see *Photo Eye Alignment Feature* on page 82.

Controller	Temporarily apply Power to Sensors	LED Status
Smart Touch (Hydraulic gate operators)	PE 1 (ON) PHOTO EYE ALIGN 	LEDs next to the sensor connections will be lit when no power is being applied. When PE is turned ON, the LEDs turn off. If they do not turn off, check for wiring issues such as a short or misapplied relay COM connections. See CAUTION on 29.
Smart DC (electromechanical gate operators)	PE 1 (ON) PHOTO EYE ALIGN 	When PE is ON, the LEDs associated with the sensor devices will be lit if the sensors are properly connected and sensors are grounded. The LEDs turn off when the ground circuit is removed.

Control Panel Overview

This section provides an overview of the electrical controls found in your gate operator. The illustrations highlight the various components and describe their function. Callouts explain where to find more information about the component.

Power Supply

Provides common and 24VAC & 24VDC terminals. Refer to *Overview of the STC and Power Supply Board* on page 52.

Smart Touch Controller

Provides inputs for peripherals & accessories. For more information, refer to *Overview of the STC and Power Supply Board* on page 52. Hy8Relay options provides eight additional user relays.

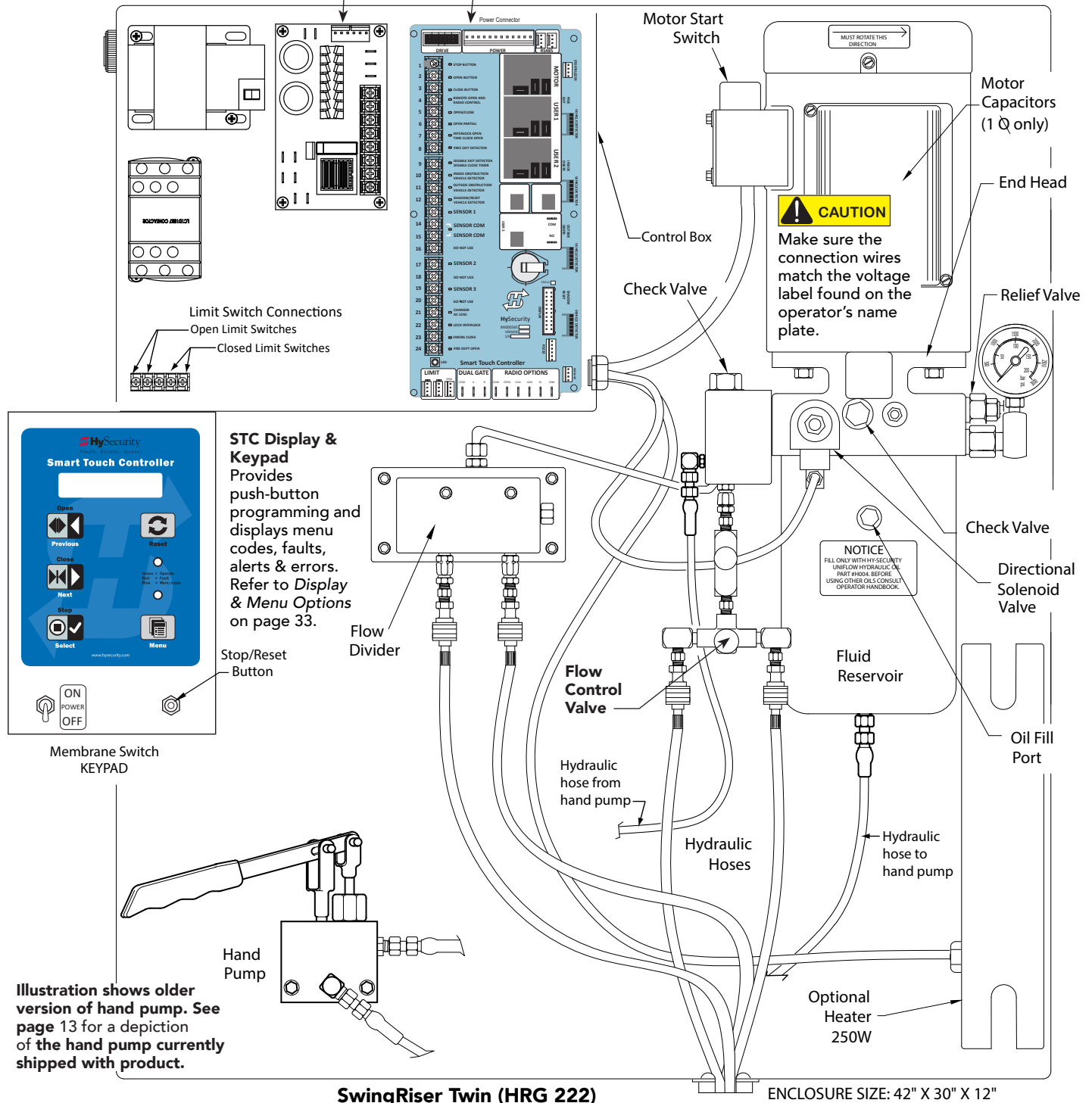

STC BOARD, POWER SUPPLY BOARD AND DISPLAY

The Smart Touch Controller provides connections for a multitude of peripherals and accessory devices. The Power Supply Board offers 8 common bus terminals, 4 terminals (24VAC) and 3 terminals (24VDC) with a 3A maximum draw. The touch-sensitive keypad and 32-character display connects to the STC with a waterproof ribbon cable. For more information about STC Inputs and connections, refer to *STC Inputs & Wiring* on page 51. For more information about the display programming, operator modes and keypad navigation, refer to *Display & Menu Options* on page 33.

Smart Touch Controller:

Provides inputs for peripherals & accessories, 2 electro-mechanical user relays (250VAC, 10A), one solid state user relay (30VDC, 3A). For more information, refer to *STC Inputs & Wiring* on page 51.

Power Supply Board

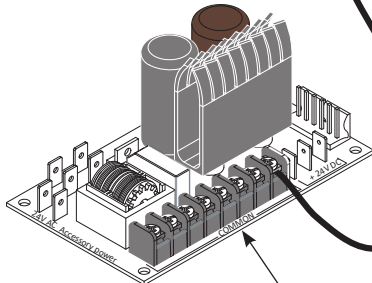

Common (COM) power terminal strip

STC Display & Keypad:

Provides push button programming and displays menu codes, faults, alerts & errors. Refer to *STC Inputs & Wiring* on page 51.

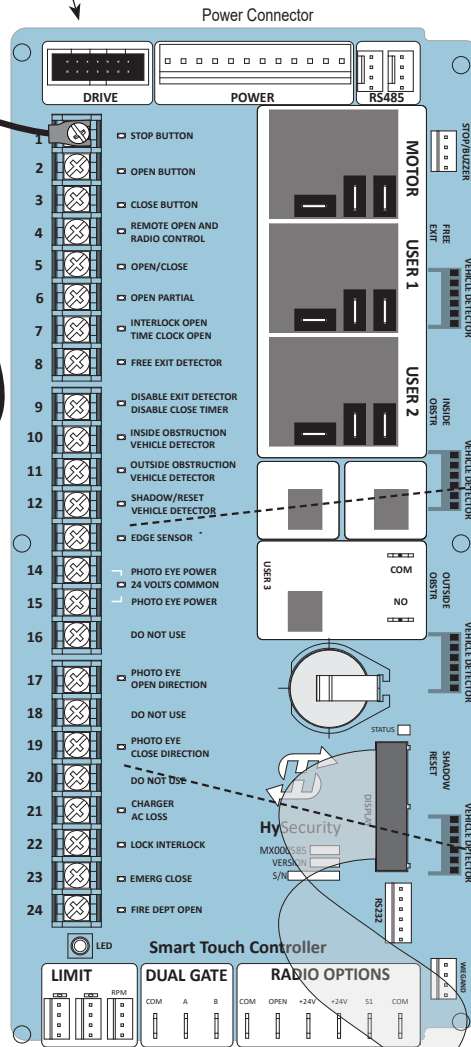
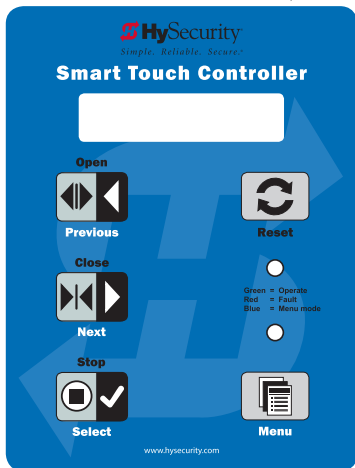

Post 2016 Label Build Year (BY 2) MX3978-01 Used on all gate operators built in 2016 or later.

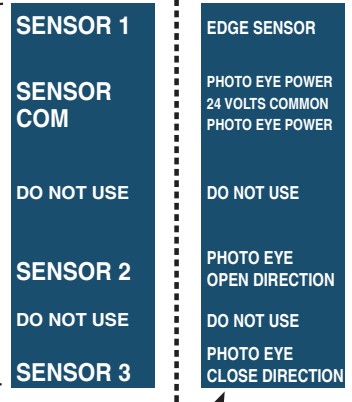

Pre-2016 Build Year (BY 1) MX3979-02 Used on replacement boards for gate operators manufactured prior to 2016.

Ribbon cable

Display & Menu Options

Highly sophisticated software provides three different modes of operation: *run*, *program*, and *fault*. How to navigate using the Smart Touch Controller (STC) keypad, interpret status display codes and program the operator is found in this section.



Keep your operator current with the latest software version. If your gate operator was manufactured in 2016 (or later), it must monitor external entrapment protection sensors to be compliant with UL 325 - 2016 Standard of Safety.

UNDERSTANDING THE DISPLAY AND KEYPAD

All system settings are performed using just four programming buttons and an easy-to-read 32 character display (OLED). RS-232 and RS-485 ports provide connections for external communication. A real time clock and an EEPROM logs events.

The STC display and keypad provide access to the operator's sophisticated software and functionality.

Three different operational modes exist:

- Run Mode – gate is operational, awaiting commands.
- Menu Mode – motor disengages and operator commands are ignored. Data entry, menu navigation, and menu selection can be accomplished via the keypad or through a START software connection using the RS-232 port.
- Fault Mode – alerts, faults, or errors appear on the display. Some errors or faults can be reset with the Reset button while more serious faults require additional troubleshooting. Fault mode indicates a need for diagnosis and resolution. Refer to *Troubleshooting* on page 87.

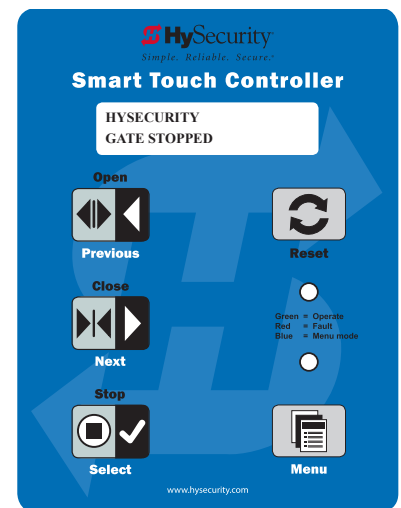

Gate Status Display in Run Mode

The keypad lets you navigate, change, or clear the information in the display menus. The singular use of these keys is dependent on the operator mode. The buttons with text above and below have two functions. Use these buttons to enter operating commands or navigate through the User and Installer Menus.

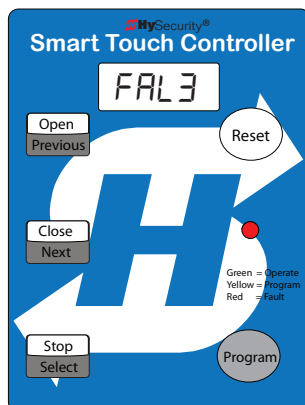

Smart Touch Display/Keypad, pre 2014

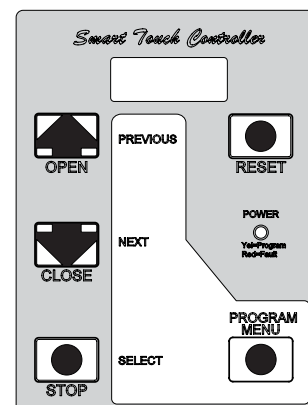

Smart Touch Display/Keypad, pre 2009

INITIAL SETUP

Once you have completed the installation of the HySecurity operator and attached the wired accessories, you're ready to program the operator. Two different approaches exist:

- Connect a laptop computer to the serial RS-232 connector and set the operator menu configurations via the S.T.A.R.T. software. Refer to the [START User Guide](#).

NOTICE: Use a laptop computer at your place of business to conveniently download the free START software before heading out into the field. This makes it easy to adjust and configure operator settings using a laptop in the field.

- Manually navigate through the User and Installer Menus using the four Menu Mode buttons located on the Smart Touch Controller Keypad. The instructions for performing this second option are provided in this section.

After installing a new operator, an initial sequence of set up prompts appears when you first turn ON the Control Box power switch. You need to answer the prompts before the gate operator will run. The operator is in "MENU" mode.

For example:

In the SwingRiser operator, you must set usage class and address 3 sensor inputs.

UC = **Usage Class**. Set the usage class to 1, 2, 3, or 4 depending on the site.

Four different vehicular usage classes are defined by UL 325.

Information about the classes can be found online through DASMA Technical Data Sheets www.dasma.com or UL 325 www.ul.com

Power switch on a SlideDriver control box

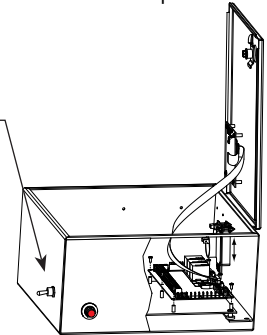

S1, S2, and S3 = Contact and non-contact external entrapment protection sensor inputs that may require monitoring per installation site and UL 325 Standard of Safety requirements.

For more information, refer to [UL 325 - 2016 Monitored Entrapment Wiring Diagrams](#) online.

Selection: Usage Class
Select between: 1,2,3, or 4

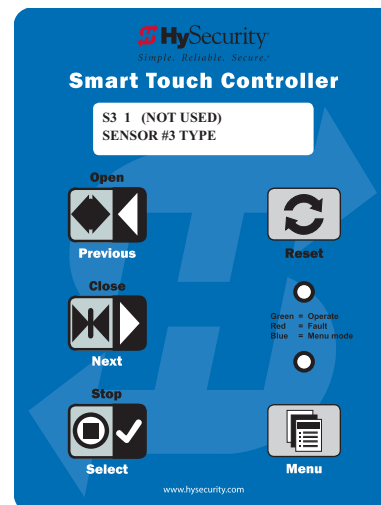
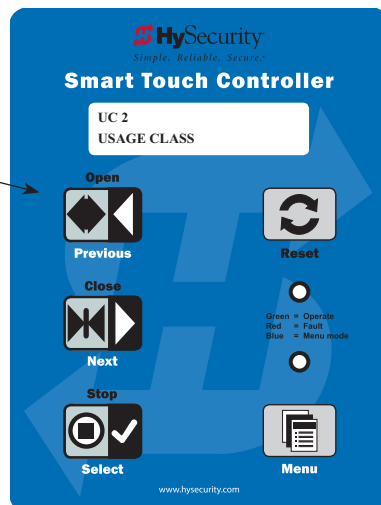

Initial Setup Using S.T.A.R.T.

With the S.T.A.R.T. application (available online after registering at HySecurity) uploaded to your PC laptop, you can choose to set site menu configurations from the comfort of your office. Then, simply bring your PC laptop to the gate operator site, connect to the gate operator using an RS-232 to serial download cable and USB adapter, and download the configured menu settings file from your laptop to the specified gate operator.

Multiple operators can be configured in this way. No switches need to be set.

All the components are securely placed in a Control Box inside the chassis.



HySecurity
a company of TheNiceGroup

To access the S.T.A.R.T. free software application, register online at HySecurity (or use your existing login ID).

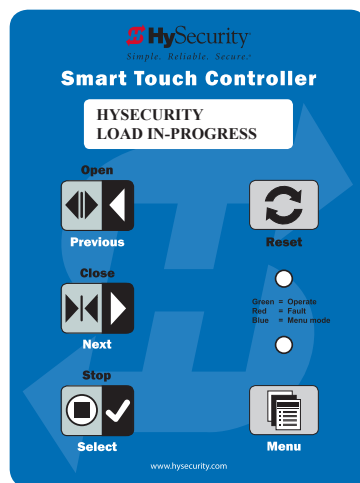
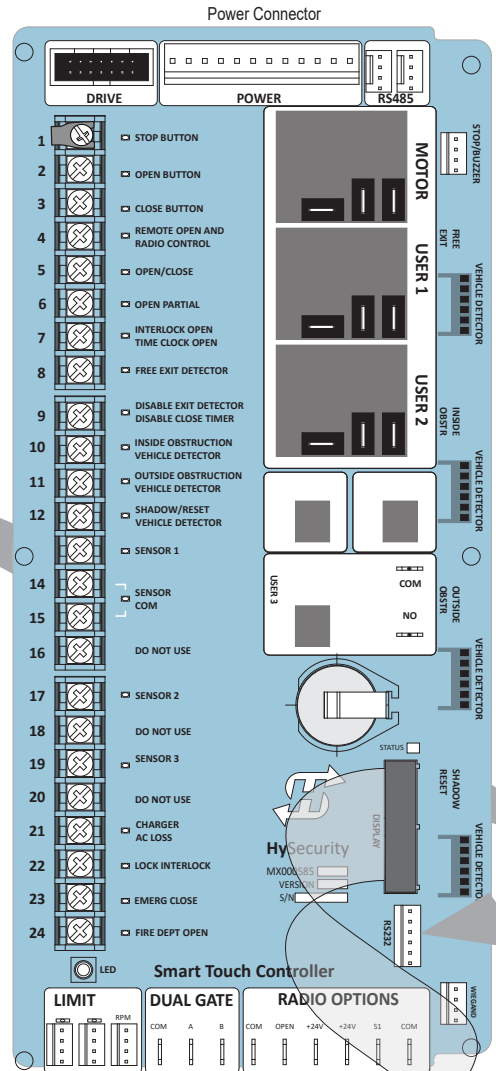

Smart Touch Controller: Downloading S.T.A.R.T. software

MENU MODE AND THE STC KEYPAD

In Menu Mode, the motor disengages and operator commands are ignored. Data entry, menu navigation, and menu selection can be accomplished using the buttons on the Smart Touch Controller keypad.

NOTE: Menu Mode automatically returns to Run Mode if no activity (i.e. key presses) occurs for two minutes.

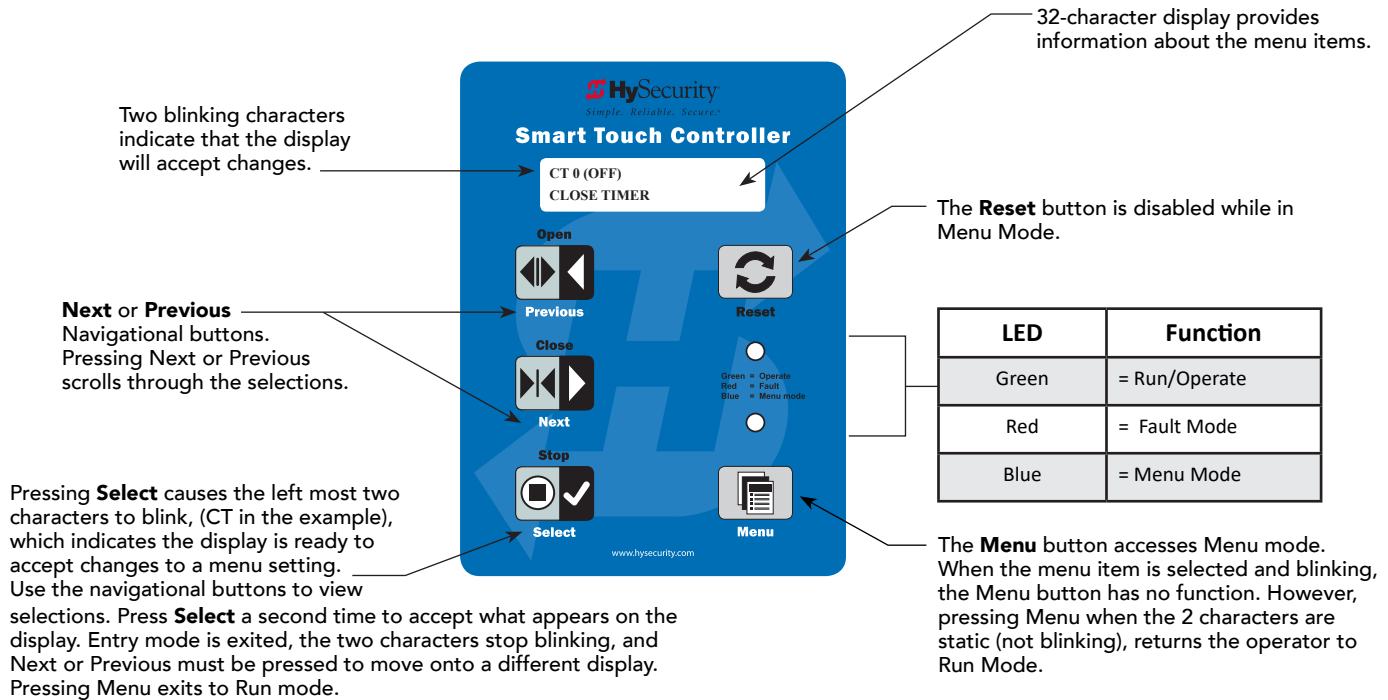

MENU MODE NAVIGATION

Navigating within the program menus is easy once you learn how the keypad buttons function. Refer to the following chart.

Smart Touch Controller: Menu Mode Navigation Buttons

To access Menu mode	To change menu item appearing in the display	To navigate through the menu item selections	To choose what item appears on the display	To navigate between menu items
Press the Menu button twice.	Press Select. Two left characters blink.	Press Next or Previous. Continue pressing Next to view all selections.	Press Select. Blinking characters become static.	Press Next or Previous. Advance - press Next Previous - press Previous

RUN MODE AND THE STC KEYPAD

The Run Mode displays appear static when the operator is ready and waiting for a run command. When the display is flashing GATE OPENING or GATE CLOSING, a command has been received and the barrier gate is in motion. The command may come from a variety of sources: a card reader, push-button remote, or recognition of a vehicle passing over a loop detector. In all cases, the operator “runs” the motor when it receives an operational command.

Three displays indicate the position or status of the gate. The keypad entry used to access the User or Installer menus, begins at one of these Run Mode displays.

32-character display identifies operator status.

Pressing Open, Close, or Stop causes the gate to perform the command.

Pressing Reset clears alerts or faults and returns to Run Mode. **NOTE:** Press Reset at any Run mode status display to view the software version. For example: **h4.53**

Pressing Menu scrolls through operator status displays and accesses the User Menu. **NOTE:** Pressing the Menu button twice, bypasses the operator status displays.

Run Mode Displays

NOTE: To access the User or Installer menus, the motor cannot be engaged and the gate cannot be moving.

VIEWING GATE OPERATOR SCROLLING STATUS

Press the Menu button once and the operator status displays scroll past in two second intervals. Pertinent information appears to provide a quick overview of the operator’s status or configurations.

The type of information that may scroll across the display includes: interlocked or sequenced gate (if applicable), operator type (OT), gate handing, Usage Class (UC), buss voltage, and life cycle counter.

LED	Function
Green	= Run/Operate
Red	= Fault Mode
Blue	= Menu Mode

The following chart describes a few of the scrolling status displays that may appear in your gate operator.

Operator Status Display	Variables	Description
Build Year	Indicates whether the gate operator was manufactured before or after UL 325 - 2016 Safety of Standard changes that require monitoring of external entrapment sensors.	All gate operators manufactured in 2016 or later will show Build Year - Post 2016 because it contains software version h4.50. If you plan to upload 4.50 software (or later) into your gate operator, you will need to set the appropriate build year according to the date of manufacture.
Dual Gate or Sequenced Gate	This display only appears when the operator is used in interlocked or sequenced gate systems and indicates the function of the operator. See <i>Bi-Parting & Dual Gate Systems</i> on page 67 and <i>Table 5: User Menu</i> on page 40.	Indicates, in an interlocked or dual gate setting, whether the operator is set to Primary or Secondary or Sequenced Gate Configuration). The setting is assigned in the Installer Menu.
Operator Type (OT)	1 = SlideDriver (HSG) all models except 50VF series 2 = SwingRiser (HRG) 3 = HydraLift (HVG) 4 = StrongArm (HTG) 5 = SlideWinder 24 6 = SlideWinder 38 7 = SlideDriver 50VF 8 = StrongArm CRASH 9 = HydraSwing 10 = HydraSupply XL	Indicates and identifies the operator.
Set Handing (SH)	L = Left and R = Right	Indicates gate handing.
Usage Class (UC)	1, 2, 3, or 4	Displays the operator's Usage Class designation per UL 325 standards.
Input Voltage VDC	The number varies depending on the voltage that the power board is providing.	Input voltage (DC Buss voltage) to the STC is shown. Helps to determine proper power connections.
Cycle Count (CC)	One cycle equals a full open and close sequence. Partial cycles are not counted	Displays the number of cycles the gate operator has incurred. Similar to an odometer, it resets to zero after 999,999 cycles.
Close Timer (CT)	The first menu item in the User Menu. NOTE: You can also access the Installer Menu from this display.	Displays the number of seconds before the open gate initiates.

Stop the Status Display Scrolling

To stop the operator status display scroll and focus on one item, press Select. Press Select a second time, to resume the scrolling display.

Change the Contrast on 7 Segment Displays

NOTE: Since sunlight does not affect readability on the OLED display, changing the display contrast is not available on models shipped with the 32 character display.

While the operator status displays are scrolling, you can change the contrast by pressing the up or down arrow keys. The display's contrast changes accordingly.

Display Power Saving Mode

To conserve energy, the display dims after a period of time if no keypress, run command or fault occurs. When an event (keypress, run command, or error/alert/fault notification) occurs, the display returns to full brightness.

Check the Software Version

Press Reset. The display indicates the software version loaded on the gate operator. To upload software, you will need a PC laptop. For more information, see *Smart Touch Analyze and Retrieve Tool (S.T.A.R.T.)* on page 99.

Check Time and Date

An easy way to determine if your operator is set for the correct date and time zone can be accomplished by taking the following steps:

1. While in Run mode (gate status appears in the display), press and hold the STOP button.
The date appears DD/MM, and then the time HH:MM.
2. If you need to change the time zone, refer to the Set Clock "CL" item in the User Menu. Refer to *Table 5: User Menu* on page 40.

USER MENU

The User Menu consists of several items which can be modified using the Smart Touch Controller keypad.

NOTE: To access the User Menu, the operator must be in Run Mode. To bypass the operator status displays, press the Menu button twice.

Access:

Pressing the Menu button, while the gate status is being displayed initiates the gate operator status to scroll. When the scrolling display stop, the first user menu item appears.

The Close Timer (or HC, Hold to Close) display is the first in a cyclical series of User Menu displays.

The LED on the keypad appears blue to indicate Menu Mode.

Use the navigational buttons, Select, Next, and Previous to change or view the menu functions. Refer to the chart, *Smart Touch Controller: Menu Mode Navigation Buttons* on page 36.

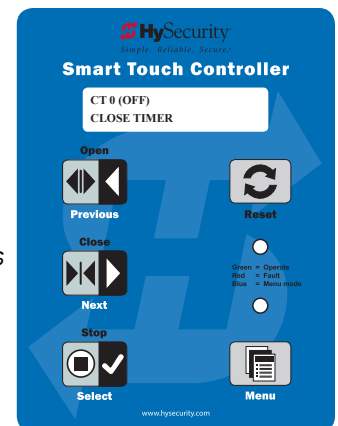

Table 5 describes the User Menu items and supplies the factory defaults. (Factory default settings shown in bold.)

TABLE 5: USER MENU

User Menu	Setting Options	Menu Tasks & Explanations	STC Wire Connections
CT 0 (OFF) CLOSE TIMER	0 = (OFF) Timer disabled 1 second to 99 seconds	The Close Timer assigns how many seconds before the open gate initiates closure. It provides a security precaution in case a CLOSE pulse is missed. Keep the setting at 0 if a hard-wired, push-button control device is being used. Refer to HC. NOTE: When the Hold to Close is set to 1 or more seconds, the Close Timer display does not appear and HC 1 becomes the User Menu entry display.	Not applicable (N/A)
HC 0 (OFF) HOLD TO CLOSE	0 = off 1 = on	Set to 0 to produce a gate closure when a momentary signal is transmitted. Set to 1 if a constant hold to close signal, such as a push button control, is being used. A setting of 1 also deactivates the automatic close timer and causes its menu to disappear. The Hold to Close replaces the Close Timer display as the User Menu entry display. NOTE: To comply with UL 325 Type D protection, set HC to 1. Type D UL 325 compliance means no automatic closing device, such as a timer, loop sensor, or similar device shall not be employed.	COM Close
HO (OFF) HOLD TO OPEN	0 = off 1 = on	Similar to Hold to Close, but configures the Open inputs for a constant-hold function. 0 = Momentary open signal 1 = Constant hold open push button required To comply with UL 325 Type D protection, you must set HO to 1.	COM Open
AP 0 AC LOSS	0 = UPS FAIL OPEN 1 = UPS FAIL CLOSE 2 = AUTO OPEN 3 = NO CLOSE TIMER	This menu item only appears if the operator is DC powered. The setting configures how the gate functions when AC power fails. For more information, refer to the supplemental documentation.	COM Terminal #21 UPS Terminal strip 24 VDC to control box power disconnect switch - and +
RO 0 (OFF) RADIO OPEN/CLOSE	0 = off 1 = on	A setting of zero, configures radio input for open only. Setting 1 adds the capability for radio input to close the gate, but only when it is fully open.	COM RADIO Open
BF 2 (ON 2 SEC) WARN BEFORE OPER	0 = off 1 = warning buzzer on throughout gate travel 2 = warning buzzer on for 2 seconds of gate travel 3 = warning buzzer on during gate travel	Controls the warn-before-operate buzzer and can be configured three ways: Set to 0: Buzzer is disabled. The buzzer will still beep if alerts, faults, errors, or entrapment occur. Set to 1: Buzzer beeps for 3 seconds before gate moves and continues through entire length of travel. Set to 2: Buzzer beeps for 3s before gate moves and continues for 2s of travel. Set to 3: Available on barrier operators only and UC 4 if sensor inputs set to 1 "NOT USED".* Buzzer beeps when gate starts to move and continues throughout gate travel. NOTE: * Gate operators or replacement boards manufactured in 2016 or later.	Not applicable (N/A)

User Menu	Setting Options	Menu Tasks & Explanations	STC Wire Connections
FA 0 (OFF) FORCE OPEN ALERT	0 = off 1 = on	Intended for highly secure facilities. Set to 1, the operator sounds the 3-second "warn before operate" buzzer alarm and initiates a closure if the gate is forced open and the closed limit switch disengages. The motor starts to secure the gate. If the gate does not fully close within 4s, the motor turns off and the buzzer sounds for 30 seconds. The display shows ALERT 1 - FORCED OPEN.	N/A
DA 0 (OFF) DRIFT CLOS ALERT	0 = off (standard) 1 = on (detailed)	Set to 1, the operator sounds the 3-second "warn before operate" buzzer alarm and initiates an open command if the gate is forced, or drifts, off the open limit switch. The motor starts to reopen the gate. The motor runs for a maximum of 4s and, if the gate is not fully open at the end of this period, the buzzer sounds for 10s. The display shows ALERT 2 - DRIFT CLOSED.	N/A
PE 0 (OFF) PHOTO EYE ALIGN	0 = off 1 = on	Set to 1, the operator serves as an aide in photo eye transmitter/receiver alignment. See <i>Supply Power to the Sensors on page 34</i> . NOTE: If the operator doesn't run when the power switch is initially turned ON, check the alignment of the photo eye and all the photo eye connections.	Sensor 1, 2 or 3 Sensor COM
CL 0 SET CLOCK	0 = off 1 = on	To adjust the hour, minute, day, or month to a different time zone, select 1. Use menu navigational keys to select and change the date and time. When your selections are complete, press Menu to return to User Menu mode.	N/A
LD 5 LCD CONTRAST	5 0 through 9	Adjusts the contrast of the display. Available settings from low contrast 0 to 9 high contrast, with a factory default setting of 5. NOTE: Not used or available with the 32 character OLED display.	N/A
LG 0 (OFF) VIEW EVENT LOG	0 = off 1 = on	With v4.53 (or later) software, you can set LG to 1 and view abbreviated event logs on the display. These messages are helpful for diagnostic purposes and reviewing the gate operator's event history. Over 300 events can be logged before the software begins overwriting the existing history. See <i>Access the Event Log through the User Menu on page 96</i> .	N/A
DS 0 (OFF) DIAGNOSTIC LOGS	0 = off (standard) 1 = on (detailed)	Set to 0, the STC records pertinent operator events such as faults, errors, or menu manipulation. When experiencing intermittent problems, set this item to 1 to record all operator open and close events, in addition to the normal alert, fault and error logs. This parameter automatically resets to the default 0 (off) after 24 hours.	To read the log file, an RS-232 cable and PC laptop loaded with HySecurity free S.T.A.R.T. software is required.
PD 0 SET PASSWORD	0 = Off 1 = On (Set Password)	NOTE: A System Address (SA) value in the installer Menu must be set before the Set Password display appears in the User Menu. To enter a password (up to 80 characters) for network connectivity, select 1. You can use the menu navigation buttons to enter the password. When the password is set, the display returns to the 0 setting.	Network: Ethernet or RS-485 HyNet configuration

INSTALLER MENU

The Installer Menu options provide more advanced configurations for the gate operators. Access to the Installer Menu is through the User Menu. The navigational buttons are the same in both menu modes. Refer to *Menu Mode Navigation* on page 36.

Access:

While a static gate status is being displayed, press the Menu button twice. (Bypasses the operator status displays.)

When the Close Timer display appears (Hold to Close, if the Close Timer display is hidden):

1. **Access the Installer Menu** by simultaneously pressing and holding the Reset and Open buttons.
2. Release both buttons and the display changes, indicating you have arrived at the first item in the Installer Menu.

NOTE: Installer Menu options can also be configured through the use of a laptop computer and S.T.A.R.T. software. See *Smart Touch Analyze and Retrieve Tool* information found on the HySecurity website

Table 6 describes the Installer Menu items and supplies the factory defaults. (Factory settings shown in bold.)

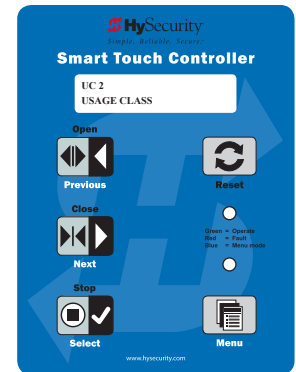
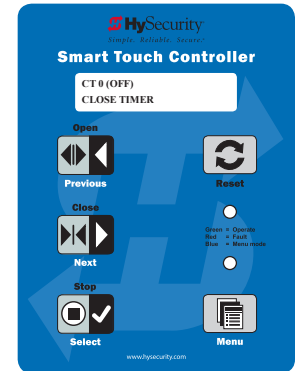
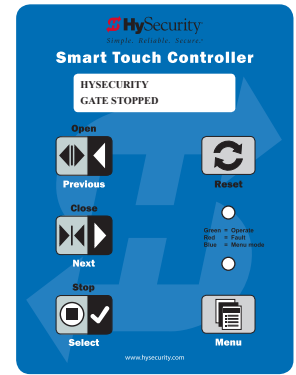

TABLE 6: INSTALLER MENU

Installer Menu	Setting Options	Menu Tasks & Explanations	STC Wire Connections
OT 0 <model name>	0 = Operator Type 1 = SlideDriver (HSG) all models except 50VF series 2 = SwingRiser (HRG) 3 = HydraLift (HVG) 4 = StrongArm (HTG) 5 = SlideWinder 24 6 = SlideWinder 38 7 = SlideDriver 50VF 8 = StrongArm CRASH 9 = HydraSwing 10 = HydraSupply XL	Select the appropriate number for the operator. NOTE: This menu item only appears if the Smart Touch Controller is being replaced. CAUTION: If you are replacing an STC board, remember to transfer the operator's menu settings from the existing board to the replacement board. Refer to the installation instructions that accompany the replacement STC board.	Not applicable (N/A)

Installer Menu	Setting Options	Menu Tasks & Explanations	STC Wire Connections
AD 0 AC/DC GATE	0 = gate disabled 1 = AC (alternating current) 2 = DC battery-power 3 = HyInverterAC – Power Supply	Usually, power type (AC or DC) is factory set. Select the type of power that the gate operator uses and is appropriately wired for.	Not applicable (N/A)
SP 0 SET SPEED (or indicate Modbus control)	0 = gate disabled 1 = No ModBus communication** 2 = 2 ft/s 3 = 3 ft/s **NOTE: A setting of 1 indicates no ModBus communication or wiring is present. The VFD uses its factory settings to control speed.	NOTE: This menu item only appears on the SlideDriver operator if it is part of the 50VF series. It does not appear with any other operator type. Set the maximum speed for the gate. CAUTION: Slow Down extended limit ramps must be installed on the drive rails! See <i>SlideDriver Slow Down Limit Ramps</i> on page 24.	N/A
UC 0 USAGE CLASS	0 = gate disabled 1 = single family dwelling 2 = multi-family 3 = industrial * 4 = guarded location * *not serving the general public	Designates the UL 325 Usage Class (UC). The installer sets the usage class for the operator to function. NOTE: The usage class setting does not appear on Crash products.	N/A
SH 0 GATE HANDING	0 = gate disabled R = viewed from the secure side, the gate moves right to open L = viewed from the secure side, the gate moves left to open	NOTE: Handing only appears on slide gate operators. On slide gates, the installer sets the operator's handing before the operator will function, so an R or L appears in the display. See <i>Gate Handing</i> on page 21.	N/A
BU 0 LOUDEST BUZZER	0 = buzzer not set 1 = Frequency 1 * (on) 2 = Frequency 2 * (on) *Select the loudest buzzer	Usually, set at the factory. If menu item appears, select either buzzer 1 or 2. Make sure to choose the loudest audible buzzer sound for your operator type.	N/A
FD 0 (OFF) FACTORY DEFAULTS	0 = user settings (custom) 1 = reload factory settings	Select setting 1 to return the operator to factory defaults which globally restores all menu settings back to new operator status. NOTE: If factory defaults are restored, any customized menu settings will need to be reprogrammed. You can save your customized menu settings using a PC laptop & S.T.A.R.T.	N/A
DG 0 (OFF) DUAL GATE	0 = solo operator (off) 1 = Secondary unit 2 = Primary unit 3 = Sally Port A 4 = Sally Port B	Establishes communication after wiring dual gate connections between two operators in Primary/Secondary or Sally Port site configurations. Refer to 72. This menu item appears if the sequenced gate menu item (SG) is set at 0 (off).	Dual Gate COM (Gate 1) to Dual Gate COM (Gate 2) A to A B to B
SG 0 (OFF) SEQUENCED GATE	0 = off 1 = Loop Layout/Site #1 2 = Loop Layout/Site #2 3 = Loop Layout/Site #3 4 = Loop Layout/Site #4	Establishes communication after wiring two or more gate operators as sequential gates. This SG menu item only appears if the Dual Gate menu item (DG) is set to 0 (solo operator). NOTE: After selecting SG settings, consider accessing the User Menu in each gate operator to address the Close Timer (CT) setting.	Connect Dual Gate COM (Traffic Gate) to Dual Gate COM (Security Gate) A to A B to B

Installer Menu	Setting Options	Menu Tasks & Explanations	STC Wire Connections
CH 0 (AC) CHARGER TYPE	0 = AC powered charger 1 = Solar powered charger	NOTE: Does not appear on an AC-powered operator. The menu item only appears when using the DC Charger unit and designates the charger type.	
FO 0 (DISABLED) FIRE DEPT OPEN	0 = disabled 1 = enabled	Provides the Fire Dept. Open input. When set to 1, the open signal received by the operator overrides all photoelectric eyes and edge sensors, and opens the gate. Pressing the Open or Reset button is required before the gate can be closed.	+24V Fire Dept Open (#24)
OC 0 (DISABLED) EMERGENCY CLOSE	0 = disabled 1 = enabled	Enables the Emergency Close input. When set to 1, the constant hold close overrides vehicle detectors, photo eyes and edge sensors, and closes the gate. Pressing the Reset button once or the Open button twice is required before the gate will open.	+24V EMERG CLOSE (#23)
SE 2 IES SENSITIVITY	1 = maximum sensitivity 2 = moderate (default) 9 = lowest sensitivity	Adjusts the sensitivity of the inherent entrapment sensor. Available settings are 1-9 with 9 being the least sensitive.	N/A
SS 0 IES STOP ONLY	0 = (off) Stop and reverse for 2s 1 = (on) stop only	A setting of 0, stops the gate and then reverses its direction of travel for 2 seconds. To stop gate travel with no reversal, the optional setting 1 can be selected if the gate operator is at a Usage Class IV site and assigned a UC 4 classification.	N/A
LC 0 LEAF DELAY CLOSE	0 = none 1 to 7	Only appears if the gate operator is set up as a Primary or a Secondary. Available settings are 1 to 7. Each numerical increment adds ½ second, to a maximum of 3 ½ seconds time delay, before the operator activates when commanded to close.	
LO 0 LEAF DELAY OPEN	0 = none 1 to	Only appears if the gate operator is set up as a Primary or a Secondary. Available settings are 1 to 7. Each numerical increment adds ½ second (with a maximum of 3 ½ seconds) time delay following a command to open before the operator activates.	
RT 0 (60 SECS) MAXIMUM RUN TIME	0 = 60 Seconds max run 1 = 300 Seconds max run	Allows an optional setting of 300 seconds if changed to [RT 1] as opposed to the maximum run timer default setting of 60 seconds.	N/A
PO 0 (OFF) PARTIAL OPEN	0 = none 7 to 99 seconds	Activates the partial open input and allows an adjustable distance by setting the open duration. The available time settings are 7 to 99 seconds. The default setting [PO 0] leaves this input inactive.	Open Partial #6 COM

Installer Menu	Setting Options	Menu Tasks & Explanations	STC Wire Connections
EC 0 STOP ONLY EYE CLOSE LOGIC	<p>0 = Close eye stops only 1 = Two second reversal to open on swing, slide, or vertical gates. Reverse to full open with barrier gates, StrongArm M30 and StrongArm M50. 2 = Reverse to full open.</p>	<p>If the close photo eye is triggered, the default setting is non-reversal while the gate is traveling in the close direction. If the obstruction is cleared within 5 seconds, gate travel continues. If you set the gate operator to optional setting EC 1, when the close photo eye is triggered, the gate pauses and reverses it's direction for a 2-second interval, and then resumes moving in the close direction if the photo eye clears within 5 seconds. (See exception for barrier arms.) A setting of EC 2 causes the gate to reverse and travel full open when triggered.</p> <p>NOTE: In software versions h5.56 and h4.55 or later the following changes occurred: Swing Gates: When photo eye close is active, the open command is operational. All Usage Class 3 or 4 gate operators: As in swing gates, an active photo eye close will no longer prevent an Open command.</p>	<p>.Sensor 1, 2, or 3 Sensor COM COM +24V</p>
EO 0 STOP ONLY EYE OPEN LOGIC	<p>0 = Open eye stops only 1 = Two second reverse to close</p>	<p>If the open photo eye is triggered, the default setting is non-reversal while the gate is traveling in the open direction. When triggered, with the optional setting of EO 1, the gate pauses and reverses it's direction for a 2-second interval, and then resumes moving in the open direction if the photo eye clears within 5 seconds.</p>	<p>Sensor 1, 2, or 3 Sensor COM COM +24V</p>
GR 0 FULL OPEN GATE EDGE LOGIC	<p>0 = Edge reverses fully open 1 = Two second reversal only</p>	<p>The default setting is to reopen fully if the edge sensor is triggered while closing. The optional setting of GR 1 sets the gate to a 2-second reversal if triggered while closing.</p>	<p>Sensor 1, 2, or 3 Sensor COM +24V 10K resistor (Edge)</p>
SR 1 REVERSE 25 REVERSAL LOGIC	<p>0 = IES reverses fully open 1 = Two second reversal only</p>	<p>If the inherent sensor is triggered, the default setting reverses the gate travel for a 2-second duration. The optional setting of SR 0 will cause the gate to reopen fully if IES is triggered while closing.</p>	<p>N/A</p>
S1 0 SENSOR #1 TYPE	<p>0 disabled 1 (NOT USED) 2 (EYE CLOSE) 3 (EDGE CLOSE) 4 (EYE OPEN) 5 (EDGE OPEN) 6 (EDGE BOTH) 7 (EYE BOTH)</p>	<p>UL 325 - 2016 sensor input setting for external entrapment protection sensor monitoring. All three sensor types must be configured to a non-zero number before the gate operator will move the gate. See <i>External Entrapment Protection Sensors: What the Installer Needs to Do</i> on page 31.</p>	<p>SENSOR 1 COM +24V SENSOR COM 10K resistor * *(Wired Edge sensor)</p>
S2 0 SENSOR #2 TYPE	<p>Same as Sensor 1</p>	<p>Same as Sensor 1</p>	<p>SENSOR 2 COM +24V SENSOR COM</p>
S3 0 SENSOR #3 TYPE	<p>Same as Sensor 1</p>	<p>Same as Sensor 1</p>	<p>SENSOR 3 COM +24V SENSOR COM</p>

Installer Menu	Setting Options	Menu Tasks & Explanations	STC Wire Connections
PC 0 NO INPUT PHOTO EYE OUTPUT	0 = Normally Open NO input 1 = Normally Closed NC input (monitored)	Changes occurring in 2016. See NOTE . The default setting is for photo eyes with Normally Close outputs. When set for NC, the connection is monitored and any short circuit fault will generate a FAULT 2 (FRLE) alert. Press the Stop or Reset button to clear.	COM +24V COM PHOTO EYE CLOSE DIRECTION
GC 0 NO INPUT GATE EDGE OUTPUT	0 = Normally Open NO input 1 = Normally Closed NC input (monitored)	Changes occurring in 2016. See NOTE . The default setting is edge sensor with Normally Closed (NC) output. The optional setting of 0 requires an (NO) output.	COM +24V COM EDGE SENSOR
TC 1 (INTLOCK) TIME CLK/INTLOCK	0 = TIME CLK (Select Time Clock) 1 = INTLOCK (Select Open Interlock)	Configures the input at Terminal No. 7 on the STC to be either for the gate interlock function, or for an external time clock to open input. The default setting is (TC_1) for the interlock function.	INTERLOCK OPEN (#7) COM
DT 0 FREE EXIT DISABLE FUNCTION	0 = Disable Free Exit 1 = Disable Close Timer	Configures Terminal #9 input to disable either the Free Exit Detector function or, alternately, the Close Timer function. The default setting disables the free exit detector. NOTE: When set to 0, the free exit is disabled while the gate rests on it's closed limit. If the closed limit is not tripped, the free exit continues to work normally.	DISABLE EXIT DETECTOR (#9) COM
OR 1 REVERSE OUTSIDE OBS LOOP	0 = Pause closing only 1 = Enable reversing to open 2 = Ignore and continue closing*	The default (1) is for full reversal when the Outside Obstruction Loop is triggered. A setting of 0 causes the gate to only pause when triggered. The gate closure begins as soon as the loop is clear again. *A setting of 2 is only available on CRASH barriers and provides for the most secure facilities where it is essential that the loop trigger is completely ignored and the barrier arm continues closing without pause or reversal.	OUTSIDE OBS LOOP (#11) COM or connection to Hy5B detector
IR 1 REVERSE INSIDE OBS LOOP	0 = Pause closing only 1 = Enable reversing to open 2 = Ignore and continue closing*	The default is for full reversal when the Inside Obstruction Loop is triggered. A setting of 0 causes the gate to only pause when triggered. Closure begins as soon as the loop is clear again. *A setting of 2 is only available on CRASH barriers and provides for the most secure facilities where it is essential that the loop trigger is completely ignored and the gate continues closing without pause or reversal.	INSIDE OBS LOOP (#10) COM or connection to Hy5B detector

NOTE: The shaded Installer Menu items do not appear when Build Year is set to 2 (BY 2). Exceptions exist for barrier arms, CRASH products, operators set to pre-2016 and Usage Class IV provisions.

Installer Menu	Setting Options	Menu Tasks & Explanations	STC Wire Connections
HD 1 HOLD CLOSE Center Loop Hold	0 = Hold Open only 1 = Hold Close and hold Open	Swing gates: Configures the function of the Center Loop (Shadow Loop) when triggered: Setting 1 - holds the gate from starting open and from starting close. This setting prevents opening and closing of the gate when the Center Loop is tripped if the gate is on either (opened or closed) limit switches. Setting 0 - holds the gate from starting closed. This setting prevents closing when on the open limit switch.	CENTER LOOP (#10) COM or connection to Hy5B detector
DL 1 STANDARD DETECTOR LOGIC	1 = Standard 2 & 3 = Quick Close 4 = Full anti-tailgate	Determines how the operator responds to a tail gate notification. See <i>Anti-TailGate Mode (Closing Logic)</i> on page 75. NOTE: Does not appear in barrier gate operators.	
RL 1 CLOSE LIM RELAY 1 LOGIC	0 = Disabled 1 = Close limit active (1 to 29 available)	Configures the function of the User 1 output relay. It has the capacity to switch both AC and DC loads and can be used for high voltage and/or high current loads. Connect devices directly to the top of the relay: COM and either NO and/or NC contacts. Multiple logic function options exist. Refer to <i>User Relays – Programming Procedure</i> on page 63.	User 1 Relay
R2 6 GATE LOCK RELAY 2 LOGIC	0 = Disabled 1 to 29 available	Configures the function of the User 2 output relay. It has the capacity to switch both AC and DC loads and can be used for high voltage and/or high current loads. Connect devices directly to the top of the relay: COM plus NO and NC contacts. Multiple optional logic function options exist. Refer to <i>User Relays – Programming Procedure</i> on page 63.	User 2 Relay
R3 1 CLOSE LIM RELAY 3 LOGIC	0 = Disabled 1 to 29 available	Relay 3 configures the function of the User 3 output relay, which is an electronic relay with the capacity for switching a DC load only. In the StrongArm M30/M50, Relay 3 is connected to the gate LED lighting and does not appear as an option in the Installer Menu.	User 3 Relay
R4 through R11 RELAY <n> LOGIC	0 = Disabled 1 to 29 available	Similar to Relay 1 Logic. NOTE: The Hy8Relay™ module option can be purchased to provide an additional 8 relay terminals. Relay #39 set aside for Factory Use.	COM NOTE: R4 through RB user relays appear on 7-segment display

Installer Menu	Setting Options	Menu Tasks & Explanations	STC Wire Connections
TL 2 (45 SECS) OPEN TIME ALERT	2 = 45 second delay 0 = 0s delay 1 = 15s 3 = 75s 4 = 105s 5 = 135s	<p>OPEN TIME ALERT lets you specify when the #8 User Relay activates. The relay turns ON when the software detects that the gate operator has been off its close limit for the specified period of time.</p> <p>NOTE: In previous versions of software, this menu item only appeared when the #8 User Relay function (Rx 8 OPEN2LONG) was configured. Now, even without the User Relay option 8 being utilized, TL is a standard Installer Menu item.</p>	User Relay 8
LT 3 (75 SECS) LOITERING ALERT	3 = 75 second delay 0 = 0s delay 1 = 15s 2 = 45s 4 = 105s 5 = 135s	<p>The LOITERING alert lets you specify when the #13 User Relay activates. When connected and configured, it indicates a vehicle is loitering on the Outside Obstruction Loop. The alert time is adjustable from 0 seconds, with 15 to 135s selectable delay timeframes in 30s increments.</p> <p>NOTE: LT LOITERING alert adjustments can be made in the Installer Menu. In previous versions of software, this menu item only appeared when the #13 User Relay function (Rx 13 LOITERING) was configured. Now, even without the User Relay option 13 being utilized, LT is a standard Installer Menu item.</p>	User Relay 13
SA 0 (OFF) STC ADDRESS	0 = No network 1 to 99 = Network "drop" address	<p>Sets the system address for network communication. 1 – 99 sets individual poling addresses.</p> <p>Refer to HyNet™ literature for more information.</p>	RS-485. Involves additional hardware & software.
NE 0 (OFF) NETWORK SETUP	0 = No network (off) 1 = Network address (on)	<p>Menu item appears when SA is not set to zero (0).</p> <p>If a system address exists a setting of 1 opens the network configuration menu.</p> <p>0 = no network communication 1 = allows configuration of network addresses. Used with HyNet™.</p>	RS-485. Involves HyNet™ & software.
ID 0 HYINVERTER DIAGNOSTICS	0 = no diagnostics displayed 1 = view diagnostics displays HYINVERTER INPUT - LINE xxx.x VAC HYINVERTER TEMP - xxx.xF / xxx.x C HYINVERTER VOLTS - BATTERY xx.x VDC HYINVERTER - BATTERY xxx.x %	<p>Controls which system diagnostics appear on the display. With a setting of 1, you can access the AC Power Supply with HyInverter AC diagnostic mode. Use the Next or Previous buttons, on the gate operator's keypad, to view the diagnostics on the STC display.</p> <p>NOTE: These same diagnostics appear on the AC Power Supply with HyInverter AC display in a constant scrolling format.</p>	AC Power Supply with HyInverter AC to STC (Modbus RTU communication protocol via RS-485.)
ELD0 RUN MODE EXIT LOOP SET	0 = Run mode 1 = Show frequency 2 = Show call level 0-7 3 = Set Frequency	Controls the Hy5B Free Exit loop detector.	Hy5B

Installer Menu	Setting Options	Menu Tasks & Explanations	STC Wire Connections
ILD0 RUN MODE IND OBS LOOP SET	0 = Run mode 1 = Show frequency 2 = Show call level 0-7 3 = Set Frequency	Controls the Hy5B Inside Obstruction Loop detector.	Hy5B
OLD0 RUN MODE OUT OBS LOOP SET	0 = Run mode 1 = Show frequency 2 = Show call level 0-7 3 = Set Frequency	Controls the Hy5B Outside Obstruction Loop detector.	Hy5B
SLD0 RUN MODE SHADOW LOOP SET (Reset Loop Set)	0 = Run mode 1 = Show frequency 2 = Show call level 0-7 3 = Set Frequency	Controls the Hy5B Shadow/Reset Loop detector.	Hy5B

SETTING THE CLOSE TIMER

The Close Timer assigns how many seconds will pass before the gate operator initiates closure of a fully opened gate after all open commands and reversing sensor inputs have ceased and loops cleared. It is recommended that every gate operator have the close timer set to a specific number of seconds (for example, 5 seconds) unless a hard-wired closing device is connected to the gate operator, such as a “hold to close” push button station.

To adjust the time (1 to 99 seconds) it takes before the operator initiates gate closure, take the following steps:

1. At a gate status display, press the Menu button twice. This accesses the User Menu and the Close Timer display appears.

NOTE: If you want gate personnel to operate the gate with the Hold to Close feature found in some push button stations, then set the Hold to Close menu item to 1. When the Hold to Close menu item is active (set to 1), the Close Timer menu item is unavailable.

2. Use the Select, and then Next or Previous buttons to navigate and change the number of seconds appearing on the display. Refer to *Menu Mode Navigation* on page 36.
3. To exit the User Menu, press the Menu button. The gate status appears in the display indicating you have returned to Run Mode.

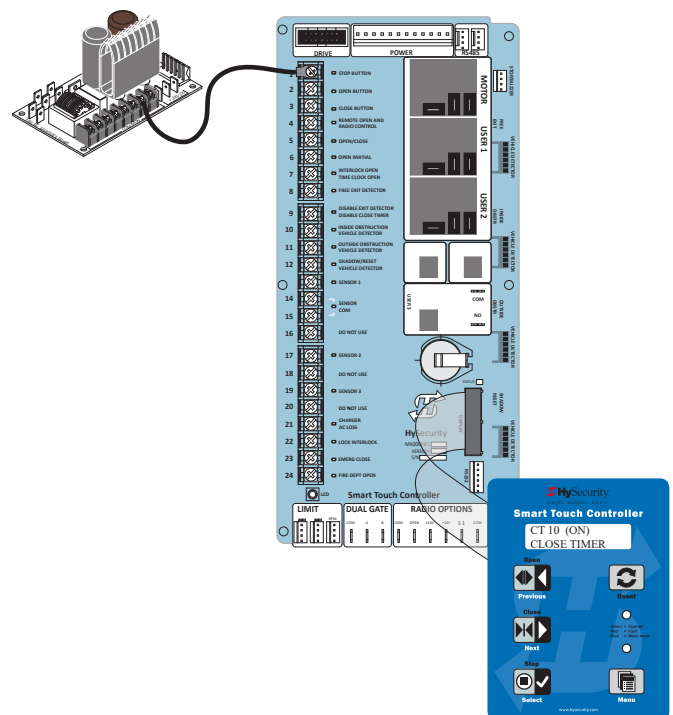

TEST THE OPERATOR

Complete the installation by testing the operation of the gate.

NOTE: The operator must be turned on and in Run mode. A Run mode display appears on the STC. If a Run mode status does not appear on the display, press Reset. If an error, alert, or fault appears on the display, refer to the *Troubleshooting* section to learn how to clear the display and return to Run mode.

1. Press Open to open the gate.
2. Test the operator.
 - Cycle the gate a few times by pressing the Close and Open buttons.
 - If installed for emergency fast operation, test the EMERGENCY CLOSE using the constant hold device. Observe the travel speed of the gate when you press and hold the Emergency Close button. It will close a second or two faster than normal operation and ignore any photo eye, vehicle loop, or other safety sensor inputs.

NOTE: If additional accessories are to be added, read about *STC Inputs & Wiring* on page 57.

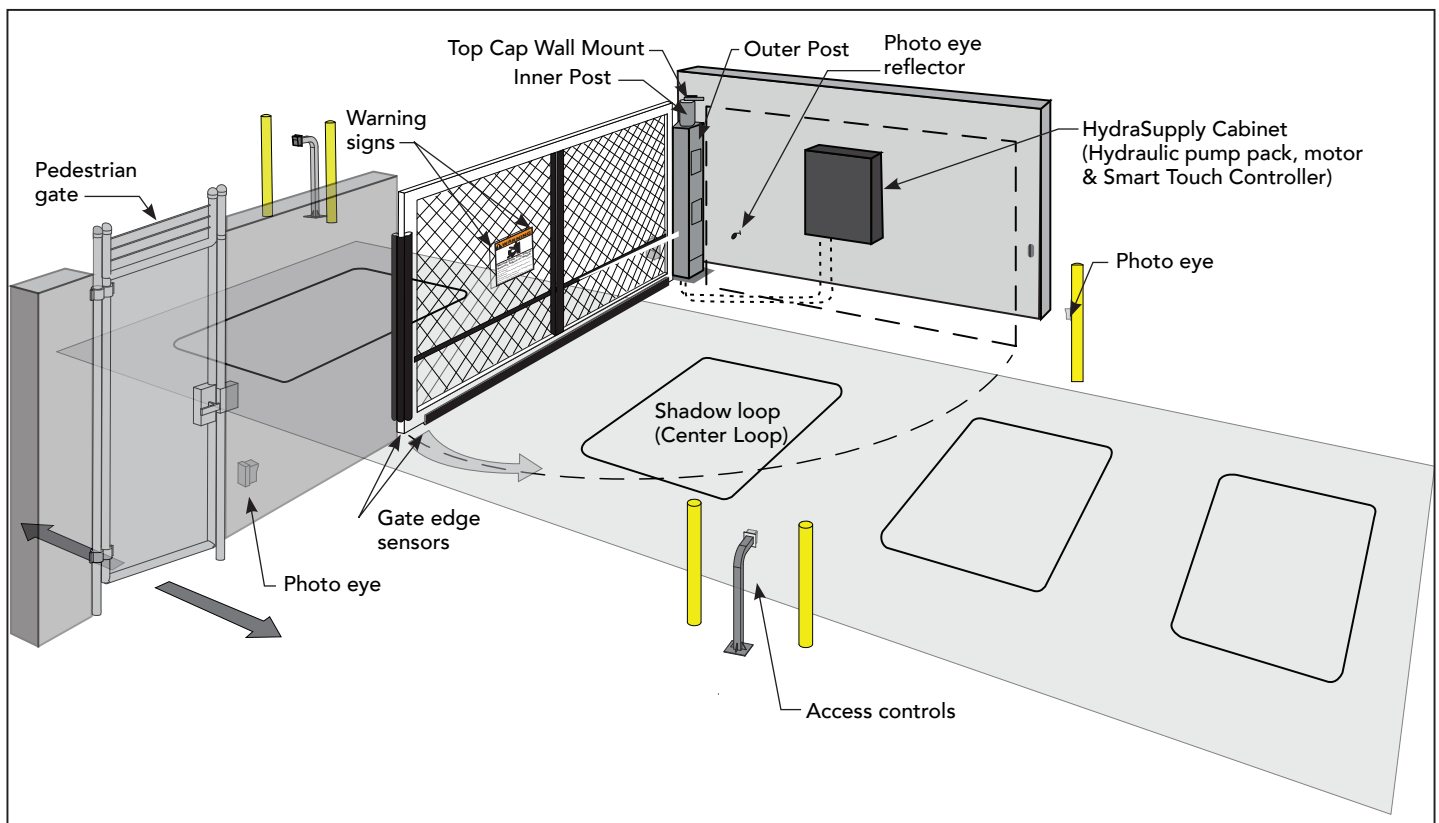

SwingRiser site example

STC Inputs & Wiring

This section provides information about the Smart Touch Controller, its inputs for peripheral connections, and its monitoring capabilities. This section explains how to:

- Make Connections on the Smart Touch Controller
- Integrate with Security Systems
- Adapt User Relays for your Gate Site

Hy5B
Refer to the [HySecurity website](#) for more information about Hy5B installation and use.

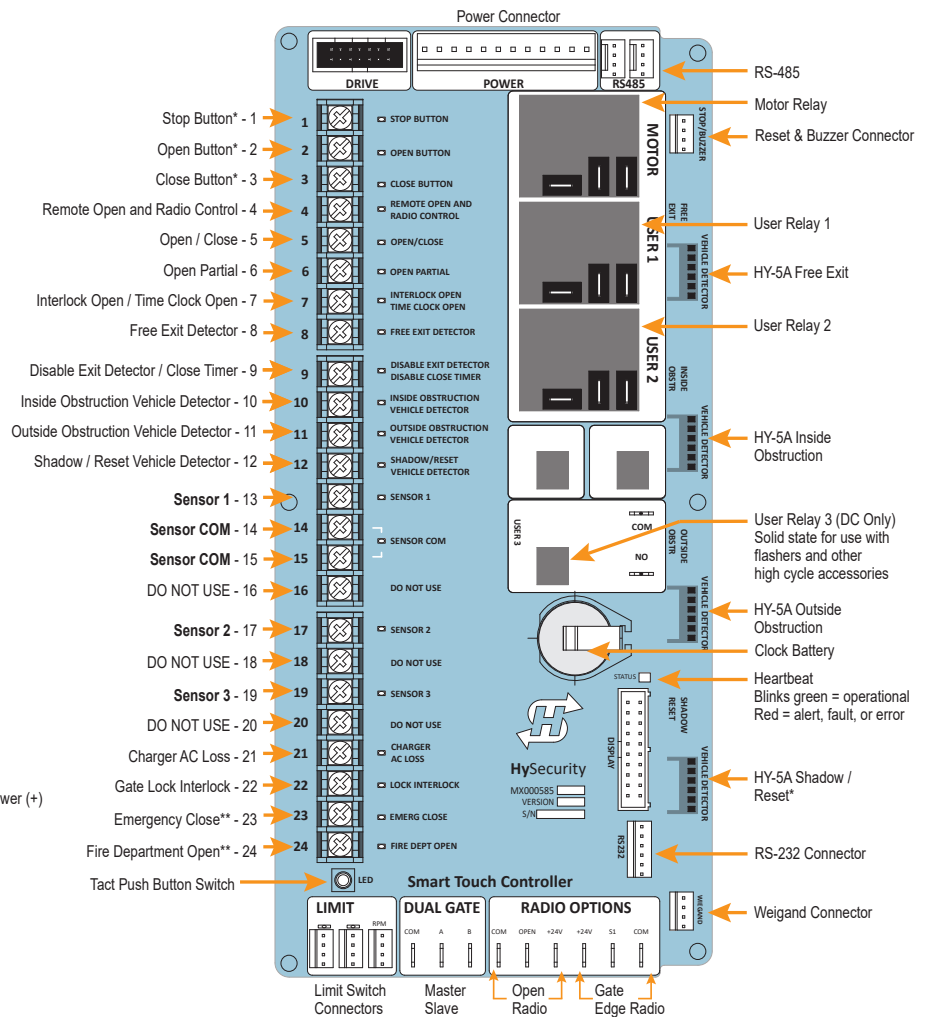
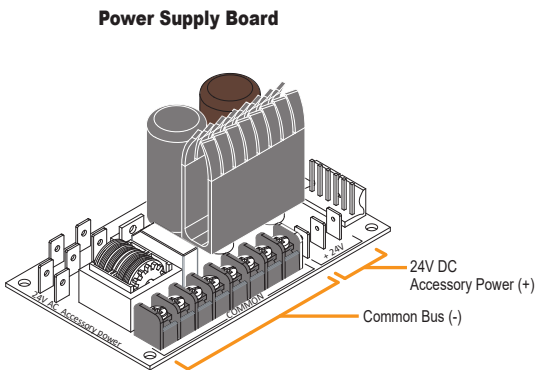
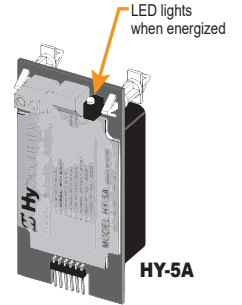
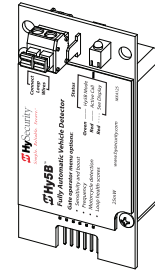

OVERVIEW OF THE STC AND POWER SUPPLY BOARD

The Smart Touch Controller uses LED's to indicate active inputs when AC power is present. For operators that use only DC power, you can push a Tact push button to show the active inputs. This Tact push button is at the bottom left corner beneath the #24 terminal input.

On a new operator, no active inputs should appear until external accessories and wiring are attached. If any inputs are active before connecting external wiring, refer to *Troubleshooting* on page 85.

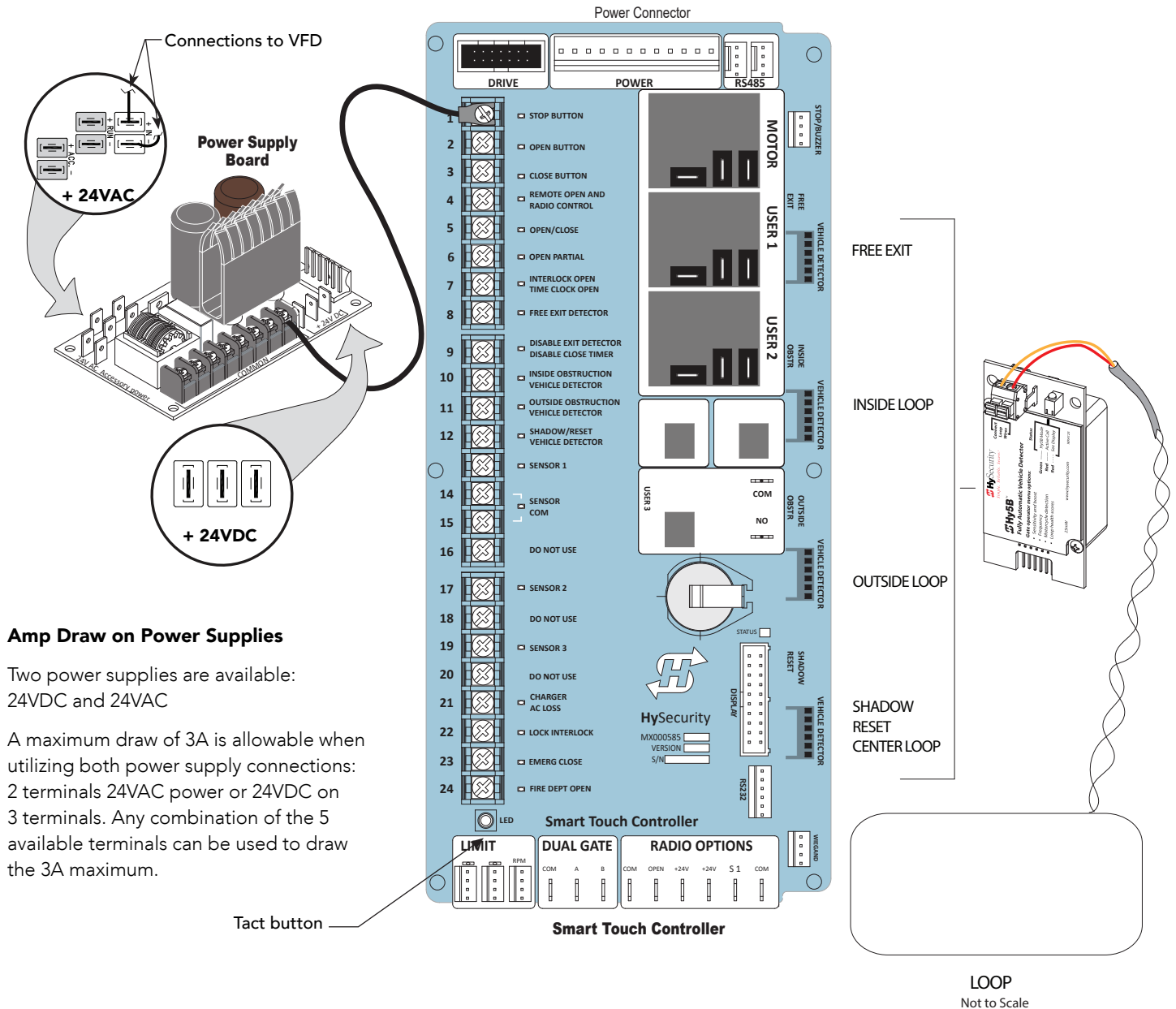

INTEGRATING WITH SECURITY SYSTEMS AND HyNET™ GATEWAY

HySecurity hydraulic gate operators provides a 2-wire, serial interface (RS-485 connection) which allows remote access to one or more operators. With software protocols provided by HySecurity, bi-directional status updates and control commands are easily integrated with a central controller (computer or server), which becomes the primary (master) to the connected operators. Up to 31 physical operators can be polled from the central master command station. Reset requests, gate control, gate status, and gate faults can be monitored and information can be retrieved from the central command station.

The RS-485 interface is also used to communicate with the HyNet Gateway, a web-enabled interface. To view the user guide and quick start information regarding HyNet Gateway SFP 4/1, go to the HySecurity website, [Technical Support Installation Manuals](#).

NOTE: Connect HyNet power to +24VDC on the Power Supply Board. Do NOT connect HyNet to +24V terminal under RADIO OPTIONS.

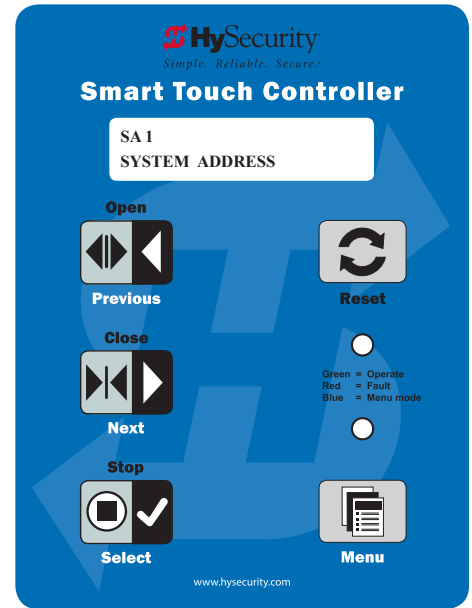
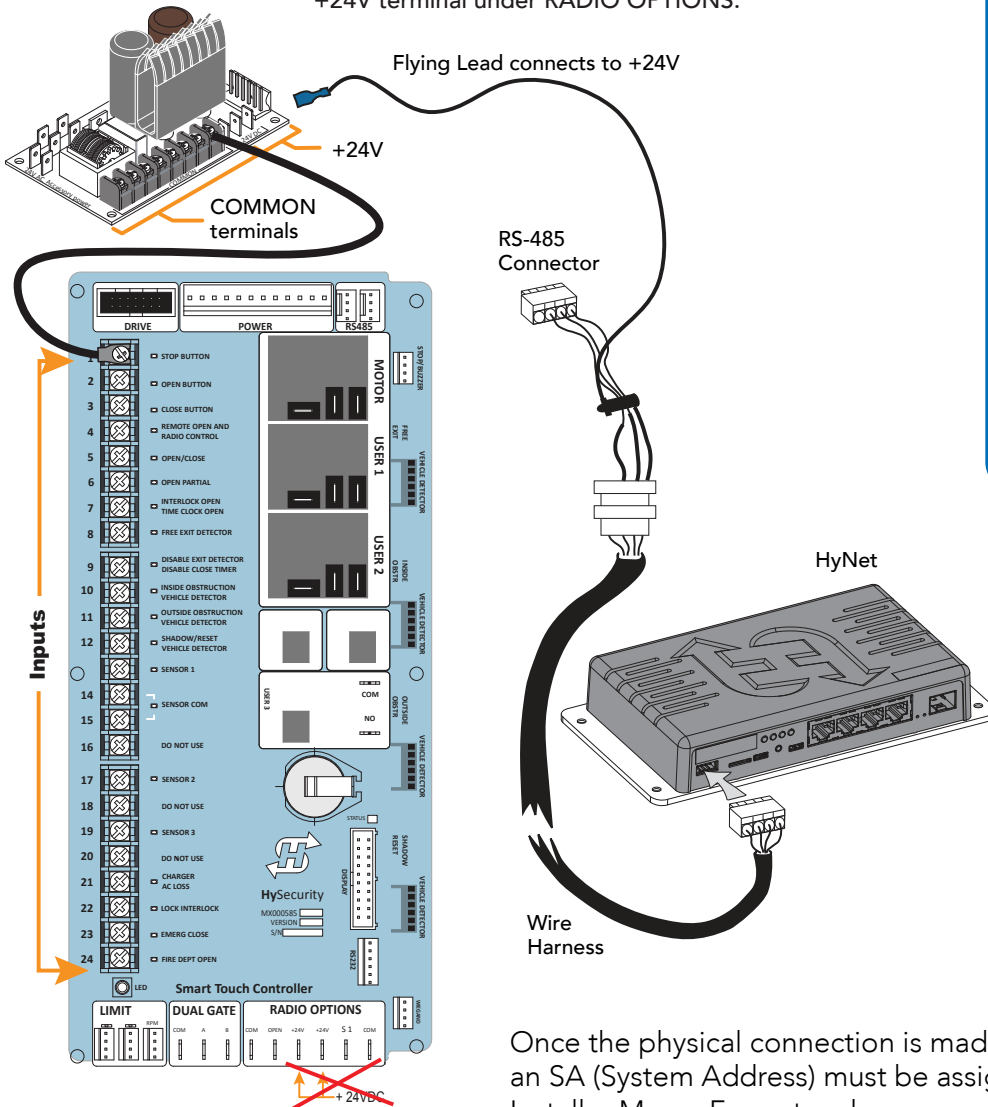

SA Display in the Installer Menu

Once the physical connection is made and protocols are established, an SA (System Address) must be assigned for each operator through its Installer Menu. For network communication, choosing a "SA" of 1 to 99 establishes individual network polling addresses. A "SA" of zero means no network communication is desired.

If you plan to connect operators to a networked central master command station, contact HySecurity for software protocols and additional information. Refer to *Contact Information on page 2*.

SMART TOUCH CONTROLLER INPUTS

When using AC power, an LED lights next to any active input.

1. Test the open and close function of the gate before wiring to accessory devices (external control inputs). This makes it easier to troubleshoot if an unexpected functionality arises.

NOTE: If you are using the operator strictly in a DC capacity, the Smart Touch Controller has a tact button you can push which lights an LED next to the active inputs. This button is in the bottom left corner of the STC board. Press the SHOW LEDs push button switch to verify the status of the terminal inputs.

2. All the Smart Touch Controller inputs listed below are shown as a single input. The second wire is connected to the Common Terminal Bus on the Power Supply Board.

NOTE: The Emergency Close and Fire Dept. Open inputs are an exception and require a +24V input. The +24V is located on Power Supply Board next to the Common Bus. See drawing on previous page.

STC TERMINAL INPUTS



Use Terminal Inputs 4, 5, 6, and 7 for external control devices. DO NOT connect an external control device to Input Terminals, 1, 2, or 3 unless the controls are located in clear view of the entire gate area and are being constantly monitored and supervised.

NOTE: UL 325 2016 sensor input label changes shown in **Bold**.

Smart Touch Controller Inputs Chart

No.	Smart Touch Terminal UL 325 - 2016	Smart Touch Terminal pre-2016	Wire Connections	Commonly used for...
1	Stop Button	Stop Button	Normally Closed input. Jumper to Common if input is not being used.	Line of sight, external stop button or 3-button station.
2	Open Button	Open Button	Do not use for radio or remote access controls. Normally Open Input	Line of sight, external open button or 3-button station.
3	Close Button	Close Button	Do not use for radio or remote access controls. Normally Open Input	Line of sight, external close button or 3-button station.
4	Remote Open & Radio Control	Remote Open & Radio Control	For radio/remote open device: Access the RO from the User Menu and set to 1. NO Input	Remote access control or radio controls
5	Open/Close Button	Open/Close Button	Connection for push button or radio controls.	Singular button device (multi-function)
6	Open Partial	Open Partial	NOTE: Terminal is only used in slide gates. Adjustable through the Installer Menu from 7 to 99.	Monitored access controls

No.	Smart Touch Terminal UL 325 - 2016	Smart Touch Terminal pre-2016	Wire Connections	Commonly used for...
7	Interlock Open/Time Clock Open LED	Interlock Open/Time Clock Open LED	The default is Interlock Open (TC 1) but can be configured as the Time Clock Open (TC 0) input. Refer to your gate operator's product manual.	Sequenced or interlocked gate inputs. Another use for this input is connection to a device that regulates the open timing.
13	SENSOR 1	Edge Sensor	Refer to <i>Table 6: Installer Menu</i> on page 40.	Connection to external entrapment protection sensors.
14	Sensor COM	Photo Eye Power - 24 Volts Common	All devices used for entrapment protection that require monitoring must be connected (wired) to SENSOR COM.	Device common power
15	Sensor COM	Photo Eye Power - 24 Volts Common	Refer to <i>How Software Handles Monitoring External Entrapment Protection Sensors</i> on page 27 and <i>Wiring HySecurity Sensors: Smart Touch</i> on page 109.	Connect external entrapment protection sensors to these terminals. The sensors energize only when the gate operator receives a run command. Use these terminals to preserve battery power. NOTE: For pre-2016 gate operators, inputs are labeled as Photo Eye Power and 24 Volts Common.
16	DO NOT USE	DO NOT USE		
17	SENSOR 2	Photo Eye Open direction	Refer to <i>How Software Handles Monitoring External Entrapment Protection Sensors</i> on page 27.	Connection to external entrapment protection sensors.
18	DO NOT USE	DO NOT USE		
19	SENSOR 3	Photo Eye Close direction	Refer to <i>How Software Handles Monitoring External Entrapment Protection Sensors</i> on page 27.	Connection to external entrapment protection sensors.
20	DO NOT USE	DO NOT USE		
21	Charger AC Loss	Charger AC Loss	Connection from battery cabinet.	DC battery type operators only.
22	Lock Interlock	Lock Interlock	Refer to user relay option 23.	Locking mechanisms.
23	Emergency Close	Emergency Close	Activate with +24. Refer to OC setting in the <i>Table 6: Installer Menu</i> on page 40.	Installer menu enabled and input +24V to trigger. Requires constant hold or supervised input. Overrides photo eyes, gates edges & vehicle detectors.
24	Fire Dept Open	Fire Dept Open	Jumper to +24. See the <i>Table 6: Installer Menu</i> on page 40.	Installer menu FO enabled and input +24V to trigger. Overrides photo eyes and gates edges.

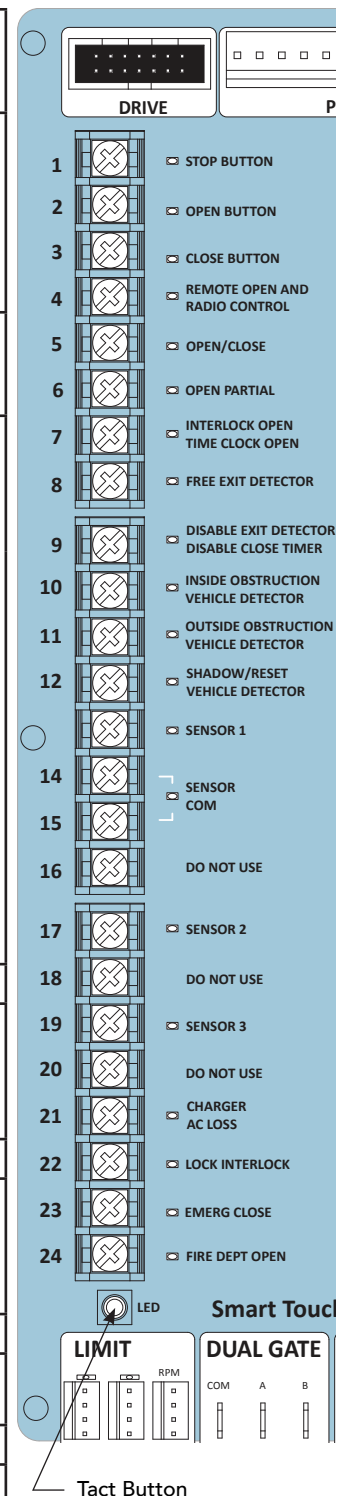

STC Inputs

CONNECTING ACCESSORY DEVICES

Sensors, such as gate edges and photoelectric beams, protect against potential entrapment. These external entrapment protection sensors must be monitored for the gate installation to be in compliance with the 2016 revision to UL 325 Standard of Safety.

NOTE: Always check your local area codes and comply with all regulations.

Other types of accessory connections are shown in the following illustration. All accessories require a minimum of two connections:

- a device input
- a Common Bus Terminal (COM)

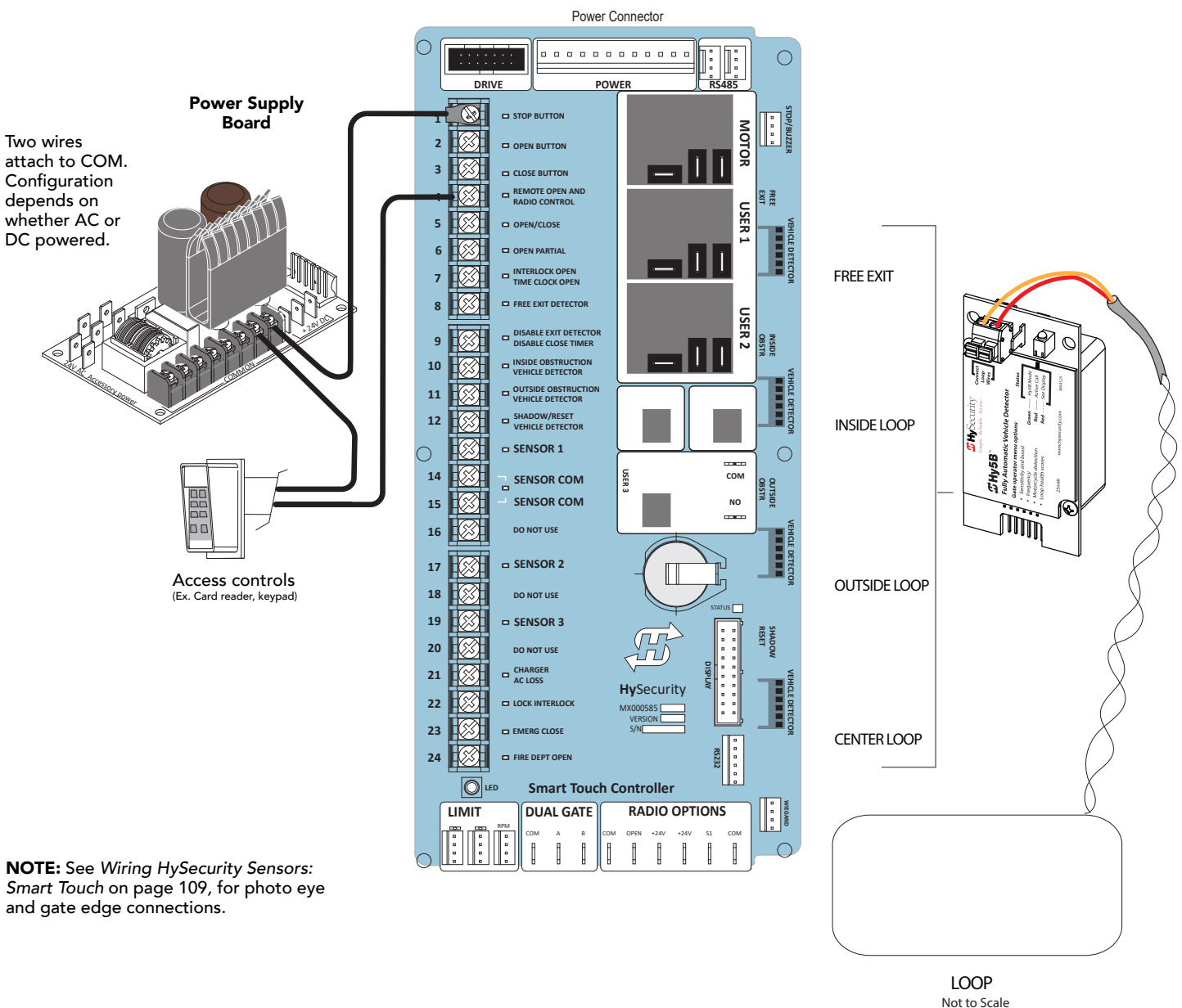

NOTE: See *Wiring HySecurity Sensors: Smart Touch* on page 109, for photo eye and gate edge connections.

USER RELAYS – PROGRAMMING PROCEDURE

The Smart Touch Controller is able to interface with many types of external devices through the use of three user programmable output relays: two mechanical relays (User Relay 1 and User Relay 2), and one solid state relay (User 3) which is used most often for connection to flashing devices.

All of the user relay functions identified and described in the table below are accessible in the Installer Menu (R1 x, R2 x, R3 x) selections.

NOTE: A setting of zero disables a User Relay. The User Relays will operate normally to 18VDC. Below 18VDC, alert notification occurs. On Crash products User 3 relay is unavailable. It is pre-wired for the LED lights.

Use the STC buttons to program the user relays according to the following steps:

1. Select the relay you wish to use through the Installer Menu. See *Table 6: Installer Menu* on page 40. For example:
R1 13 (RELAY LOGIC 1) or R2 15 (RELAY LOGIC 2).
2. Select the appropriate function (1 through 28) by changing the display to the associated number listed in the table. Use the Select, Next and Previous buttons to make your selection. Refer to *Menu Mode Navigation* on page 34.

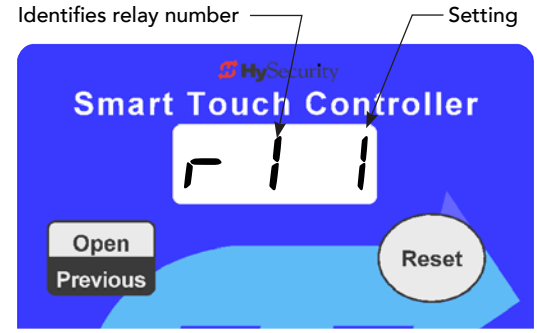

STC display (7-segment)

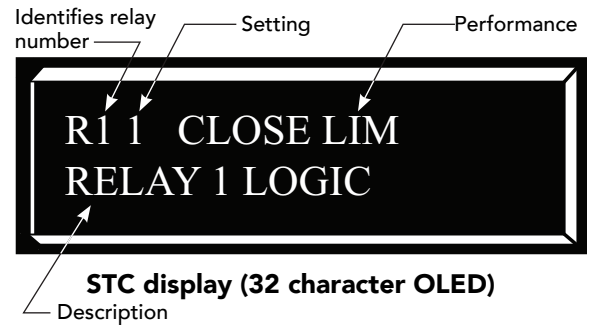

STC display (32 character OLED)

Table 7: Programmable User Relays

Setting	Performance	Description	Wire Connection
1	Close limit output	Output can be used as an interlock signal to another operator's interlock input, or simply to indicate that the gate is secure. The relay is "off" when the gate is closed. The relay energizes when the fully-closed limit is released. (Any open command energizes the relay.)	Relay 1, 2 or 3
2	Close limit pulse output	Used in a sequenced system to command a second machine to close. Generates a brief pulsed output that occurs when the close limit is triggered.	Relay 1, 2 or 3
3	Open limit output	Indicates a full-open position. This output becomes active when an open-limit is triggered and deactivates when the open-limit is released or a close command is received.	Relay 1, 2 or 3
4	Open limit pulse output	Used in a sequenced gate system to command a second machine to open. Generates a brief pulsed output that occurs when the open limit is triggered.	Relay 1, 2 or 3
5	Warn before/during operate output	Controls an external warning device. This output operates at the same time as the internal warn before operate buzzer.	Relay 1, 2 or 3
6	Gate Lock output	Controls external solenoid or magnetic locks. In both directions of travel, this output is activated about 7/10ths of a second before the operator starts moving the gate and remains active while moving. Output remains active, for a few seconds, after stopping.	Relay 1, 2 or 3

Setting	Performance	Description	Wire Connection
7	Gate forced open output	Activated if the gate is forced off the closed limit switch and the operator is not able to restore the gate to full closed position within four seconds. NOTE: This alarm resets itself in 30 seconds.	Relay 1, 2 or 3
8	Gate open too long output	Controls an external device. Activates when the gate is open longer than the user-selected period of time. Adjustable from 0 seconds with 15 to 135s selectable delay timeframes in 30s increments. NOTE: TL - Open TIME ALERT adjustments can be made in the Installer Menu. The TL Installer Menu display only appears when using this relay.	Relay 1, 2 or 3
9	Safety Mode Alert output	Controls an external device. Activated when the system is in Safety Mode or Entrapment Mode. Safety Mode occurs when the gate encounters an obstruction. Entrapment Mode means the gate is stopped. Entrapment mode occurs if the inherent entrapment sensor triggers while the system is in Safety Mode.	Relay 1, 2 or 3
10	Entrapment Mode Alert output	Controls an external device. Activated only when in the Entrapment Mode.	Relay 1, 2 or 3
11	Unauthorized Vehicle Entry output (Tailgate alert)	Controls an external device. Activated when a second vehicle enters from the outside without a valid input from an access control device. This output releases when an access control input signals open or the arm/gate reaches the close limit.	Relay 1, 2 or 3
12	Outside Obstruction Vehicle Detector output	Interlocks an entry device to prevent pedestrian use. This output is active whenever the Outside Obstruction Loop Detector is tripped.	Relay 1, 2 or 3
13	Loitering Alert	Indicates a vehicle is loitering on the Outside Obstruction Loop. Adjustable from 0 seconds with 15 to 135s selectable delay timeframes in 30s increments. NOTE: LT LOITERING ALERT adjustments can be made in the Installer Menu. The LT Installer Menu display only appears when using this relay.	Relay 1, 2 or 3
14	Gate nearing full travel output (Nearing Limit)	Applies to operators with position sensors only. Activated when the gate is 3s from expected limit switch trigger. NOTE: If the operator has not yet learned limits, it will energize Relay 14 when the motor begins moving the gate.	Relay 1, 2 or 3
15	Gate failure output (Fault mode alert)	Activated to report occurrence of a problem. Indicates the system is in an Error Mode, Fault Mode or Entrapment Mode.	Relay 1, 2 or 3
16	Motor Running output	Active when the motor is running and gate is in motion.	Relay 1, 2 or 3
17	AC Power Failure output	This relay is normally energized and drops with loss of AC power.	Relay 1, 2 or 3
18	DC Power Failure output (Low battery alert)	DC operators only. The relay activates when the battery power is very low, but the output ceases when the battery is dead. The relay is triggered when the battery is less than 20 volts.	Relay 1, 2 or 3
19	Flasher Relay	Flashes lights once per second. The relay is constantly pulsing except when the open limit switch is triggered. * Preferred connection is Relay 3, a solid state relay (except on Crash). On Crash gate operators, Relay 3 is unavailable because it is hard-wired for the LED barrier arm lights.	Relay 1 or 2* (Relay 3)

Setting	Performance	Description	Wire Connection
20	Free Exit Loop Vehicle Detector output	Active when the Free Exit Loop is tripped.	Relay 1, 2 or 3
21	Inside Obstruction Vehicle Detector output	Active when the Inside Obstruction loops is tripped.	Relay 1, 2 or 3
22	Center Loop Detector output	Active when the Reset/Center/Shadow loop detector is tripped.	Relay 1, 2 or 3
23	External Latching gate Lock Output (Prison Lock)	Activates when the Lock Interlock Input (Terminal No. 22) is active at the start of an Open cycle and remains on until the Lock Interlock releases or 10 seconds elapse, whichever happens sooner. Also, activates a Close cycle and releases 1 second after reaching the Close limit.	Relay 1, 2 or 3
24	Gate at Partial Open Position	Active when the partial open position is reached or exceeded. Not used in StrongArmCrash.	Relay 1, 2 or 3
25	DC Power OK Alert Battery OK Alert	Deactivates when the software detects a low battery voltage (below 21VDC, but greater than 18VDC) for a duration of 2 seconds or more. To slow battery drain, accessory power loads are shed.	Relay 3
26	Free Exit Vehicle Detector Pulse	Activates when the Exit Loop Detector is tripped and causes a 250mS pulse output to occur.	Relay 1, 2 or 3
27	Not Open (requires AC power)	When AC power is detected, this relay activates when the gate is NOT on the open limit. If AC power fails, or the gate is on the open limit, the relay is deactivated.	Relay 1, 2 or 3
28	Flasher (requires AC power)	Controls flashing lights that pulse 500ms per second. The relay is constantly activating except when the open limit switch is triggered or AC power fails.	Relay 1, 2 or 3
29	Set aside for Factory Use	HySecurity Testing Only	Do not use
30	Arm Break	Does not appear. Displayed only on StrongArm and StrongArmPark DC and activates if the breakaway arm switch is tripped.	
31	Warn Operate Run	Relay is active while warn before and motor running.	Relay 1 or 2
32	Partial Open Pulse	Relay pulses when partial open activated and when partial open limit reached. Often used at a sequential gate site.	Relay 1 or 2

Hy8RELAY MODULE OPTION

The Hy8Relay (extended relay module) provides 8 numbered mechanical relays. R 4, RELAY 4 LOGIC through RB, RELAY 11 LOGIC can be accessed through the Installer Menu. Set the number for the relay based on the information found in *Table 7: Programmable User Relays*.

Wire communication cable connections between the DUAL GATE ports, at the base of the STC, and the extended mechanical relay module. Refer to instructions that accompany the Hy8Relay Module.

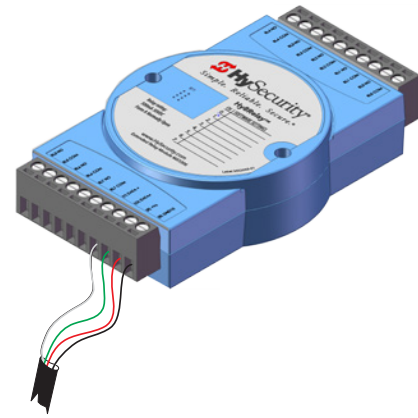

Bi-Parting & Dual Gate Systems

Configuring two or more operators to work together as an interlocked pair (Primary/Secondary or Sally Port) or sequenced gate system is easy to do with the Smart Touch Controller (STC). There is no need to order a special model or any adapters. The area of the board marked Dual Gate employs a 3-wire, RS-485 serial port for communication between the operators.

NOTE: RS-485 communication is available for networked security systems. For additional information, refer to *Connecting Sequenced Gates* on page 64. The SwingRiser Twin is comprised of two gates run with one motor and one Smart Touch Controller. SwingRiser Twin models are categorized as singular systems, not dual gate systems.

CONNECTING AN INTERLOCKED PAIR (DUAL GATE)

The Smart Touch Controller provides dual gate connections (two swing gates run by two separate HydraSupply control units). The STC programming features connect a pair of gate operators in a Primary/Secondary or interlocked Sally Port configuration. The software establishes the communication protocols when wiring the two separate gate operators. A Primary/Secondary pair of operators can be set for different open/close timing sequences (leaf delay feature) and Sally Port gates are often used at correctional facilities. In Sally Port configurations, one operator cannot open unless the other is fully closed. To learn how to connect the wiring between operators, review the wiring diagram on the next page.

NOTE: Both SwingRiser gate systems need to have compatible software versions installed on their Smart Touch Controllers.

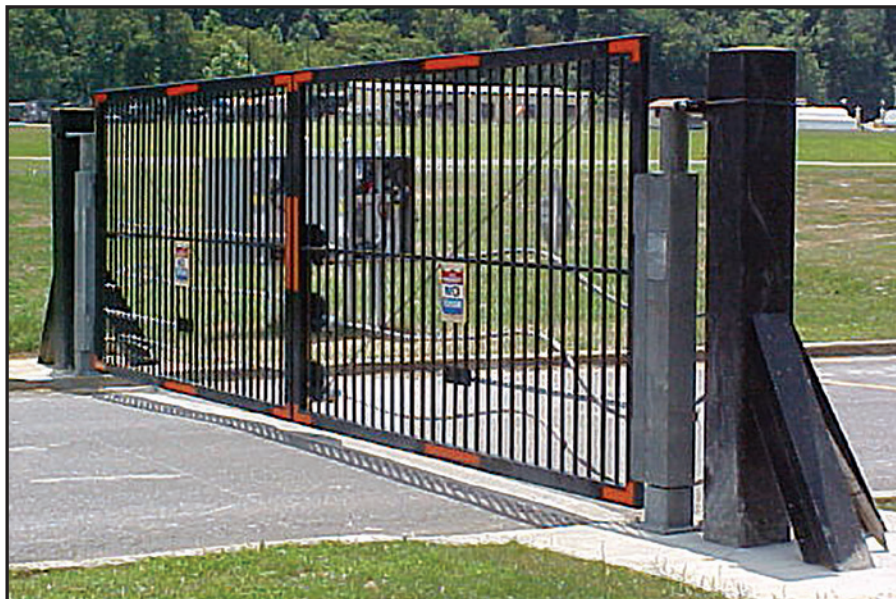

Bi-parting SwingRisers

Dual Gate Wiring Connections

To connect an interlocked pair of gate operators, simply follow the steps below.

1. As shown in the Wire Diagram, connect a shielded communications cable to the DUAL GATE inputs in each operator. The inputs are located near the base of the Smart Touch Controller. Be sure to connect the wires in pairs to the same terminal ports (A-A, B-B, COM-COM) on both operators.
2. Attach a ring terminal to the shield wire and connect it to the Smart Touch Controller's convenient ground screw.



Connect the ground shield wire to only one operator, not both. Use only 18-20 gauge twisted and shielded triple wire. To operate properly, both Smart Touch Controllers must be using the same software version.

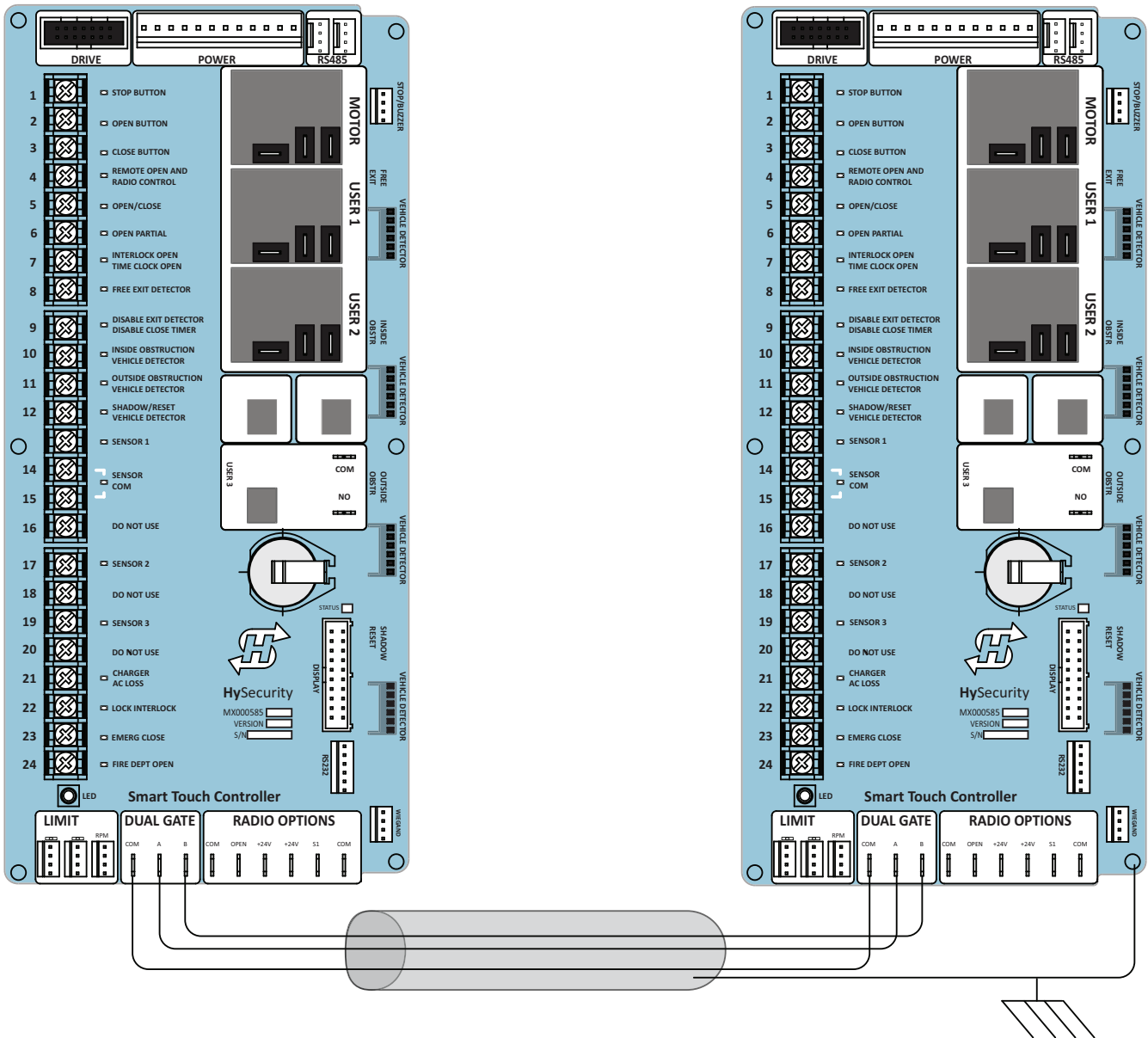

Wire Diagram: Interlocked Pair of Operators wired to DUAL GATE Inputs

Dual or Sequenced Gates: Power, Software & Accessory Requirements

When installing an interlocked pair, the following must be adhered to:

- An electrical conduit for interconnecting wires must span between the two operators. The interlock (dual gate) communication wires and any low voltage control wires must be installed in a conduit that is separate from the high voltage power cables.
- Complete the installation of both operators as separate machines and verify that their basic functions are correct as solo operators before interconnecting them.
- Be sure both operators are running the same software. The software version can be viewed on the display by pressing the RESET button.
- For up-to-date features, keep the most current software loaded on both gate operators. Software downloads are available. Make it part of your maintenance routine to check for and install software updates on a regular basis.
- External control inputs (vehicle detectors and external entrapment protection sensors) may be connected to either gate operator in a Primary/Secondary configuration, but in a Sally Port configuration, the external control inputs must be connected to Sally Port A. (Sally Port A being the first gate to open for incoming traffic. Be sure to designate Sally Port A in the dual gate menu item as 3 (DG 3) and Sally Port B as 4 (DG 4).

NOTE: If using the Hy8Relay, connect it to the dual gate spades on the Primary controller.

Programming a Dual Gate (Interlocked Pair)

Both gate operators must be programmed so they know what function they are to perform as Primary and Secondary or Sally Port A and Sally Port B. (Sally Port A being the first gate to open for incoming traffic.) The Installer Menu provides the Dual Gate (DG) menu item that sets up the functionality of the gate operators. Access this menu item by taking the following steps:

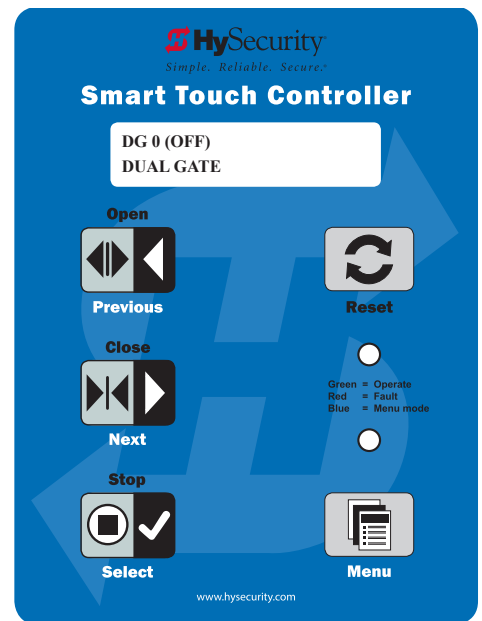
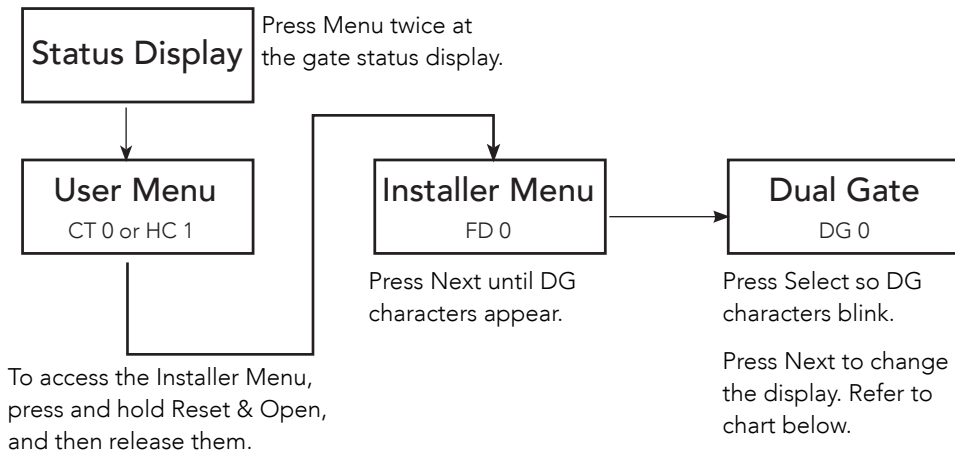

Refer to the chart below to set the operator's functionality.**

**Interlocked Gate type	Operator 1 (Primary)	Operator 2 (Secondary)
Sally Port	1. Press Next until DG 3 appears on the display. 2. Press Select to establish the operator as Sally Port A.	1. Press Next until DG 4 appears on the display. 2. Press Select to establish the operator as Sally Port B.
Primary / Secondary	1. Press Next until DG 2 appears on the display. 2. Press Select to establish the operator as Primary.	1. Press Next until DG 1 appears on the display. 2. Press Select to establish the operator as Secondary.

CONNECTING SEQUENCED GATES

Sequenced gates are slightly different than dual or interlocked gates. When two gate operators are connected as sequenced gates, a faster “Traffic Control Gate” operator (i.e. barrier arm or crash wedge) and a slower “Security Gate” operator (slide, swing, or vertical lift gate) operate in sequence to help prevent tailgating or unauthorized entry. Both operators open (Security Gate first followed by the Traffic Control Gate) and allow a vehicle through, but the faster moving Traffic Control Gate closes quickly once its reset/center loop and all obstruction loops are cleared. Upon reaching its closed limit, the Traffic Control Gate signals the Security Gate to close. Note that all shared vehicle detector loops must be cleared before the Security Gate closes.

NOTE: An emergency open or close overrides the gate sequencing and acts upon both gates simultaneously.

The Smart Touch Controller (STC) provides the sequenced gate connections and programming features, and the STC software establishes the communication protocols when wiring the sequenced gate operators. To learn how to connect the wiring between operators, review the Wire Diagram below.



The operators do not have to be of the same type, but both need to have identical software versions installed on the Smart Touch Controller. For example, a StrongArmCrash M30 can be sequenced with a security gate to provide both personnel security and crash provisions. The inherent STC software integrates seamlessly between operators and software protocols and allows RS-485 communication for networked security systems. Refer to *Integrating with Security Systems and HyNet™ Gateway* on page 53 for additional information.

To connect a sequenced pair of gate operators, follow the steps on the next page.

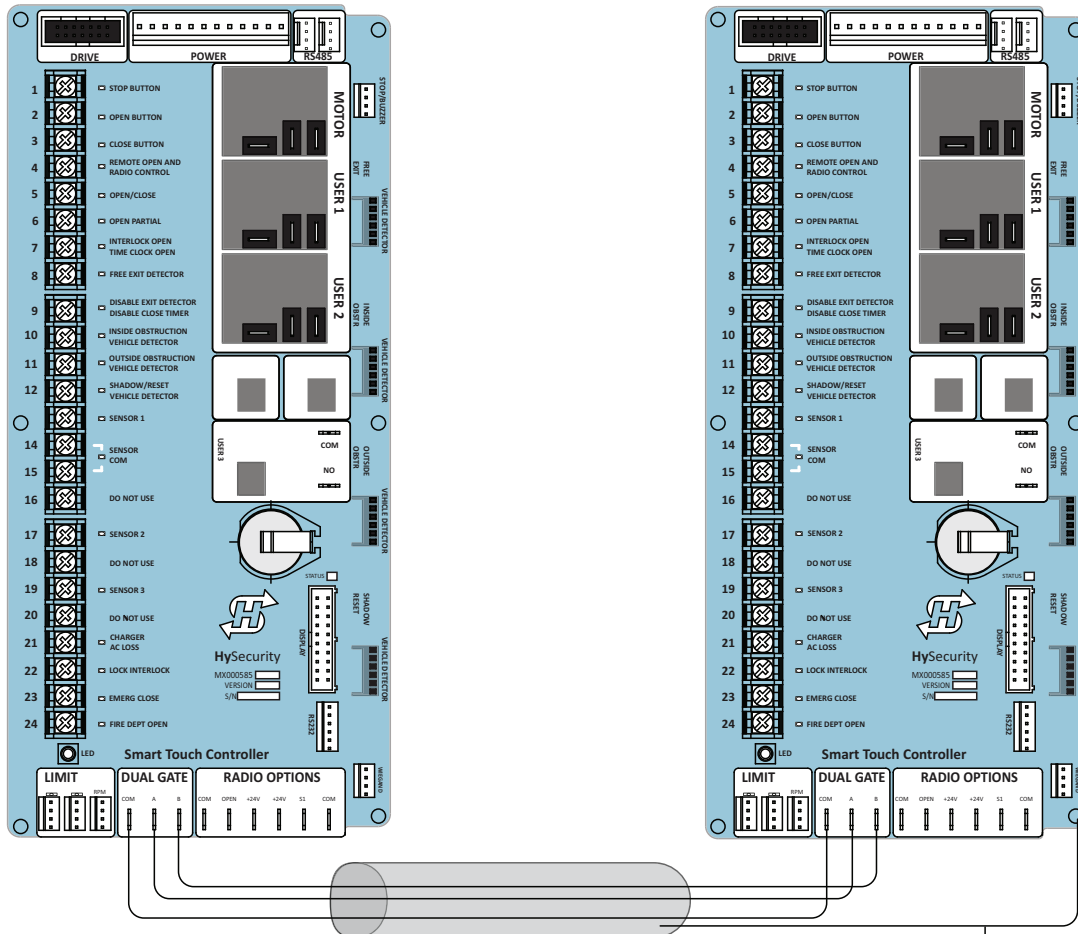

Wire Diagram: Sequenced Pair of Operators wired to DUAL GATE Inputs

1. As shown in the wire diagram on page 64, connect a shielded communications cable to the DUAL GATE inputs in each operator. The inputs are located near the base of the Smart Touch Controller. Be sure to connect the wires in pairs to the same terminal ports (A-A, B-B, COM-COM) on both operators.
2. Attach a ring terminal to the shield wire and connect it to the Smart Touch Controller's convenient ground screw.

NOTE: Connect the ground shield wire to only one operator, not both. Use only 18-20 gauge twisted and shielded triple wire.

Sequenced gates are very similar to dual gates (interlocked pair) in their Power, Software, and Accessory Requirements. To review the installation site requirements, refer to *Bi-Parting & Dual Gate Systems* on page 61.

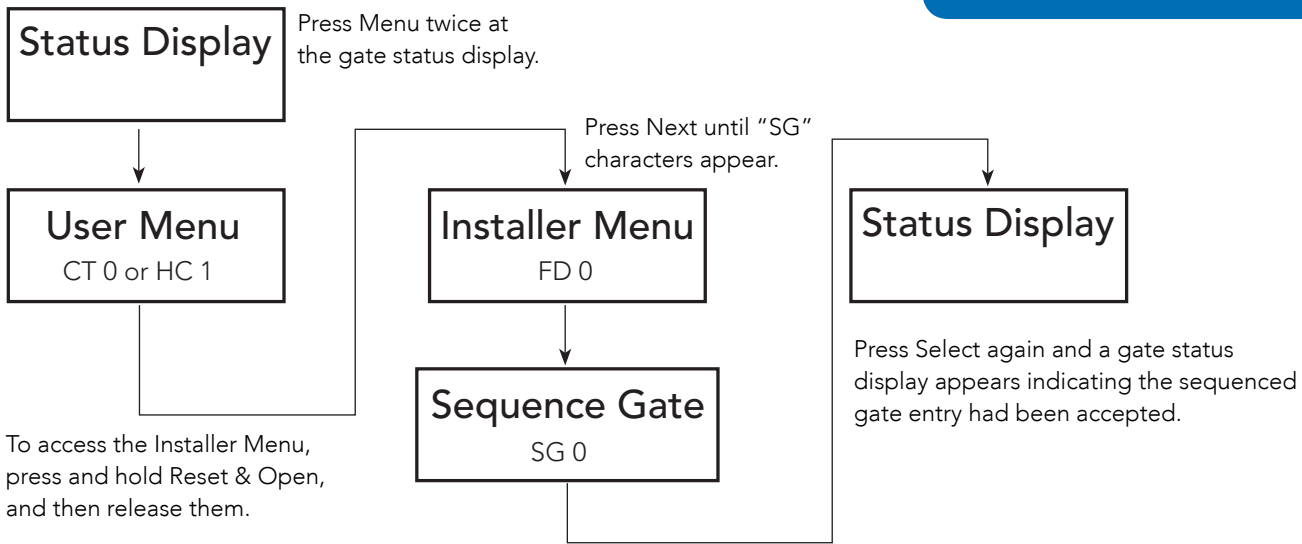
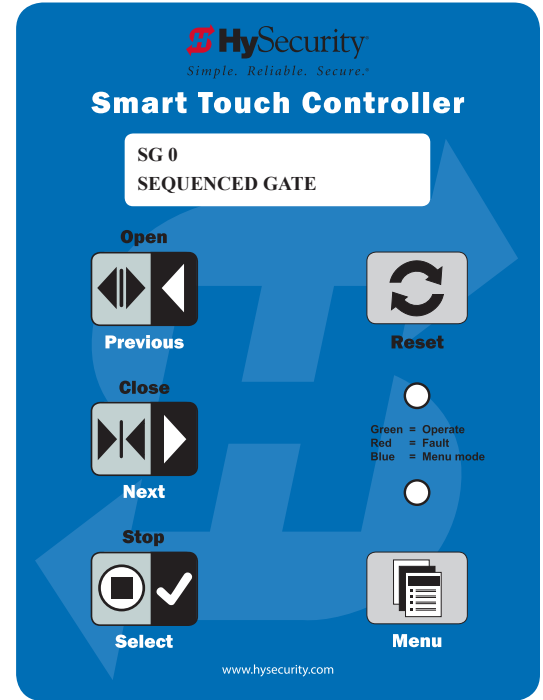

To access the Installer Menu, press and hold Reset & Open, and then release them.

Press Select so "SG" characters blink.

Press Next to change the display:

SG 1 = Sequenced Gate #1 configuration

SG 2 = Sequenced Gate #2 configuration

SG 3 = Sequenced Gate #3 configuration (only used with HydraSupply XL)

SG 4 = Sequenced Gate #4 configuration (only used with HydraSupply XL)

NOTE: Set gate operators on the site to the uniquely paired number. Refer to the site designs on the following pages.

SEQUENCED GATE: CONFIGURATION #1

Vehicle Loop Layout

SwingRiser with StrongArm M30

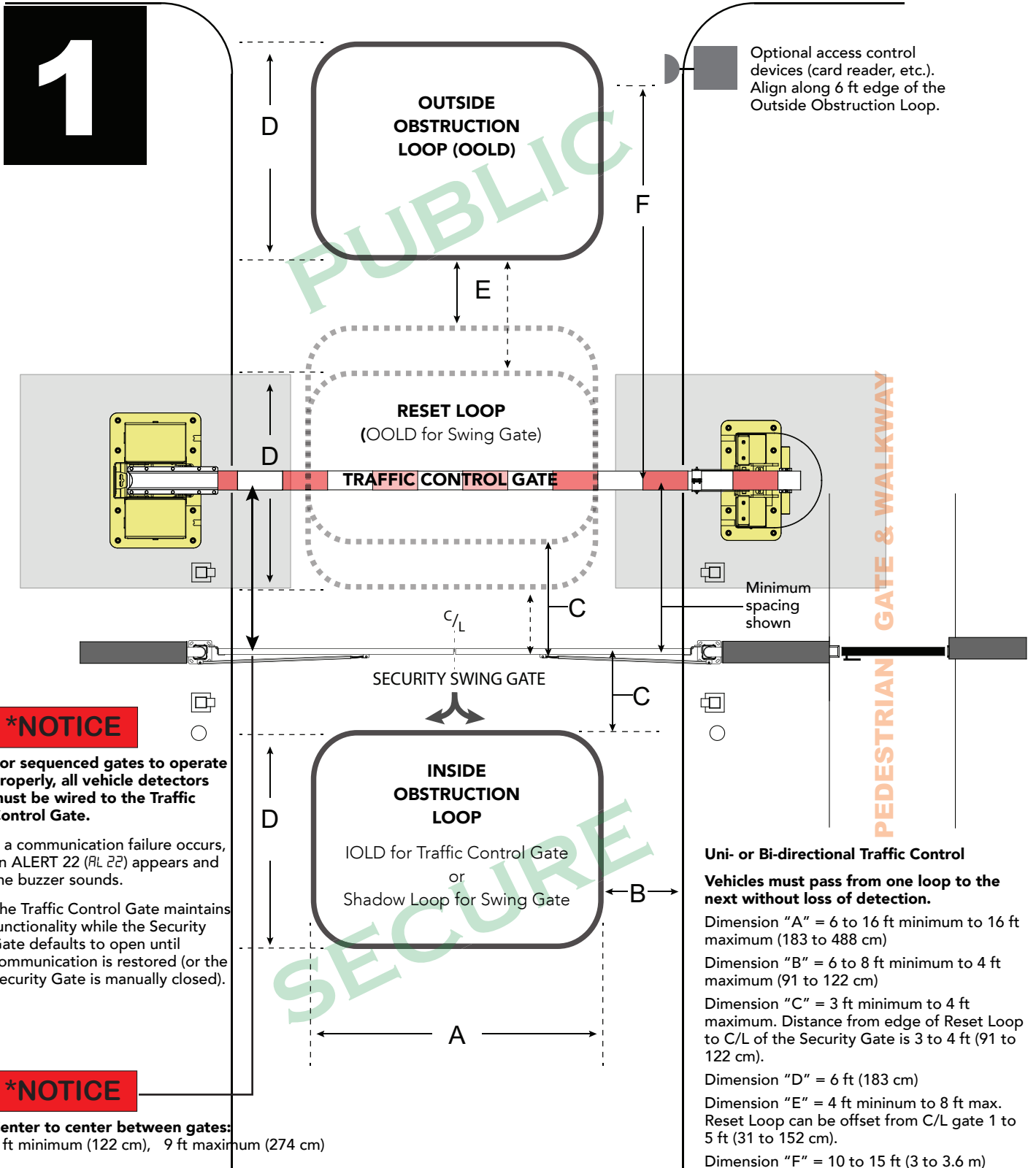

SEQUENCED GATE: CONFIGURATION #2

Vehicle Loop Layout

SwingRiser with StrongArm M30

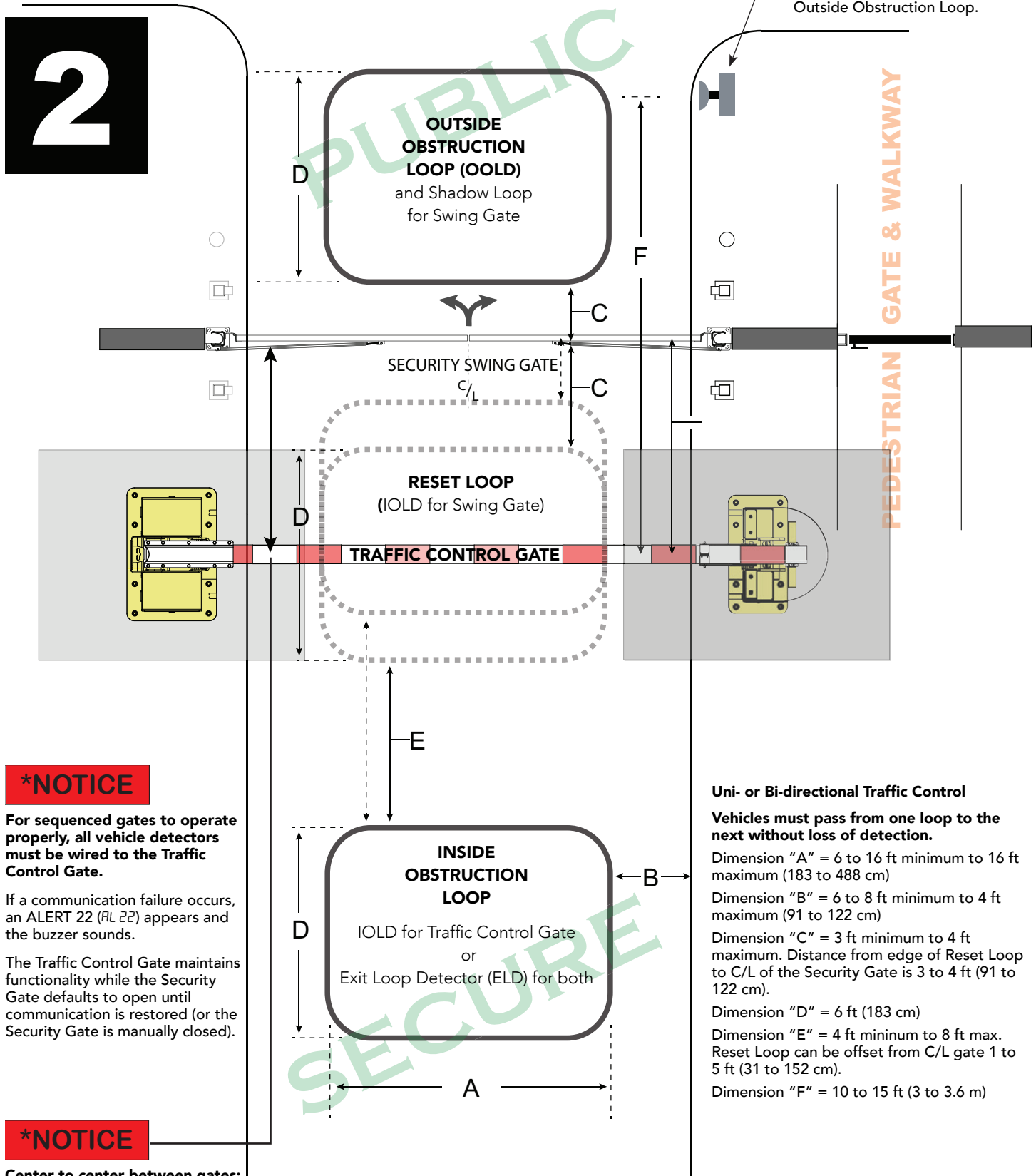

Optional access control devices (card reader, etc.). Align along 6 ft edge of the Outside Obstruction Loop.

***NOTICE**

For sequenced gates to operate properly, all vehicle detectors must be wired to the Traffic Control Gate.

If a communication failure occurs, an ALERT 22 (RL 22) appears and the buzzer sounds.

The Traffic Control Gate maintains functionality while the Security Gate defaults to open until communication is restored (or the Security Gate is manually closed).

***NOTICE**

Center to center between gates:
4 ft minimum (122 cm), 9 ft maximum (274 cm)

Uni- or Bi-directional Traffic Control

Vehicles must pass from one loop to the next without loss of detection.

Dimension "A" = 6 to 16 ft minimum to 16 ft maximum (183 to 488 cm)

Dimension "B" = 6 to 8 ft minimum to 4 ft maximum (91 to 122 cm)

Dimension "C" = 3 ft minimum to 4 ft maximum. Distance from edge of Reset Loop to C/L of the Security Gate is 3 to 4 ft (91 to 122 cm).

Dimension "D" = 6 ft (183 cm)

Dimension "E" = 4 ft minimum to 8 ft max. Reset Loop can be offset from C/L gate 1 to 5 ft (31 to 152 cm).

Dimension "F" = 10 to 15 ft (3 to 3.6 m)

Drawings not to scale.

Page intentionally left blank

Vehicle Detector Installation and Loop Layouts

HySecurity recommends that vehicle detectors be used for free exit and obstruction sensing logic only. The exception is in parking or barrier arm applications where detectors may also be used to close the gate. In applications employing our swing, vertical lift, or sliding gate operators, closing logic cannot be used except when the anti-tailgate logic is employed.

Vehicle detector functions (OR, IR, HD, DL) are configurable through the *Table 6: Installer Menu on page 42*.

NOTE: For in-depth information regarding Hy5B vehicle detectors, click [Tech Support on the HySecurity website](#) and follow the link to [Installation Manuals](#).

Anti-TailGate Mode (Closing Logic)

The Detector Logic (DL) installer menu item lets you set the anti-tailgate mode. This menu item works in conjunction with the Close Timer (CT) when the vehicle detector is triggered. If you plan to use the anti-tailgate feature, check the time delay aspect of the Close Timer (CL) setting.

The four selectable modes for DL are as follows:

Mode 1 (Default): An input from either the Free Exit, Outside Obstruction Loop (OOLD), Inside Obstruction Loop (IOLD), or the Center Loop (CLD/RESET/Shadow) will hold the gate open, reset the close timer, and ignore all close inputs. The close timer begins to count down only after all vehicle detectors are clear and no other open command is present.

Mode 2: The close timer does not wait for vehicle detectors to clear, but instead it starts counting down as soon as the open limit is reached.

Mode 3: When both inside and outside obstruction loops are simultaneously active, the gate will close immediately (unless another open command is present) once all vehicle detectors are no longer sensing active loops (i.e. vehicle loops are clear).

Mode 4: Full anti-tailgate logic includes Mode 3 functions. In addition, the gate will stop during the opening cycle when both OOLD & IOLD (reversing loops) are tripped simultaneously. When the OOLD & IOLD loops are cleared, the gate closes immediately. The OOLD & IOLD can be individually set so that, if tripped while closing, the gate may either, pause only or reverse to reopen. The free exit detector input is ignored while the gate is closing.

NOTICE: Using any vehicle detector logic mode other than Mode 1 (default) requires that all the loops be placed with the geometry and spacing as shown in the loop layout drawings. The detector Modes 3 and 4 require use of separate inner and outer obstruction detectors. Mode 4 is not available in HydraWedge SM50 or gate operators functioning with HydraSupply XL.

TailGate Alert

User Relay 11 is available for notification devices. If a vehicle is tailgating, and a flasher or audio device is connected to User Relay 11, the relay will be triggered by the tailgating vehicle crossing the loops. See *User Relays – Programming Procedure on page 63*.

VEHICLE DETECTORS AND THE SMART TOUCH CONTROLLER

The Smart Touch Controller provides an interface for up to four different vehicle detector functions.

NOTE: Standard box type 11 pin (24 VDC or 24 VAC) vehicle detectors may be connected in the traditional manner to the controller, but HySecurity Hy5B mini-detector modules plug directly into the board, making field installation much faster and enhancing performance.

The Hy5B detector communicates with the Smart Touch Controller microprocessor to achieve the following benefits:

- **Automatic Sensitivity** – The Hy5B monitors vehicle traffic over the loop and automatically adjusts the loop sensitivity based on vehicle type and volume.
- **Automatic Gate Compensation** – The Hy5B discerns gate travel over the loop and automatically compensates for its effect. The compensation allows the Hy5B to operate with a higher sensitivity which provides better detection capability.
- **No Loop Crosstalk** – Exclusive use of Hy5B vehicle detectors in HySecurity gate operators, completely eliminates crosstalk and the need to set frequency levels.
- **Vehicle Counting** – Hy5B detects passenger vehicles and motorcycles.
- **Automatic Lightning Suppression** - Where lightning strikes occur often, connecting to the ground terminal minimizes the chance of activation or lock-up.
- **Health Scores for Loop** – Hy5B monitors the loop for changes that are indicative of possible problems. A score is accessible through the event log, LG menu item.
- **Automatic Hy5A emulation mode** for backward compatibility.

Hy5B Installation

To install an Hy5B vehicle detector, you will need to take the following steps:

- Test the vehicle loop
- To use all the features of Hy5B, update the software version on the gate operator to the latest version using S.T.A.R.T. and a PC laptop. Access free software updates from the HySecurity website
- Install the Hy5B vehicle detector
- Fully cycle the gate at least 2 times to allow the detector to adjust to the effects of the gate during travel. Drive a test vehicle over the loops.

Test the Vehicle Loop

Run diagnostic tests on the vehicle loops before installing Hy5B vehicle detectors to ensure the loops are in good working condition. The following tests cannot guarantee a functioning loop, but failure of either test means that the loop may be damaged or need to be replaced.

1. Test – Measure the resistance of the loop and lead-in wire. It should not exceed 4.0 ohms.
2. Test – Measure the resistance to earth ground with a Megohmmeter (Megger). It should be 100 Megohms or more. Below 50 mega-ohms, install a new loop.

NOTE: Loops may function at 100 Megohms or less, but will not be reliable (for example, when the ground is wet from rainfall). A low megohm reading on the resistance to earth ground usually occurs due to broken or moisture saturated insulation. Be sure to use wire with a direct burial jacket such as XLPE or XHHW wire. Do NOT use THHN wire.

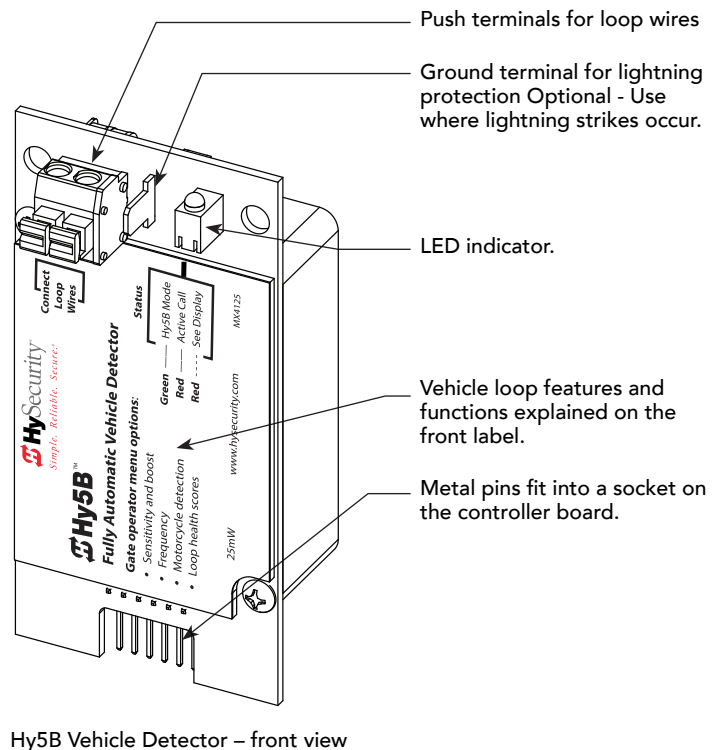

Check the Version of Software

1. In the field, open the gate operator's Control Box.
2. To view the software version, press the RESET key. To use Hy5B features, the software version must be h4.55 or h5.56 (or later). Otherwise, the Hy5B reverts to Hy5A emulation mode.
3. If you wish to update the software, download the current S.T.A.R.T. software to your PC laptop, and then load the gate operator code to the controller board before installing Hy5B vehicle detectors. See for updates.



NOTE: Hy5A emulation mode does not include all the features of Hy5B. If you are replacing Hy5A detectors and updating the gate operator software, be aware Build Year 1 (BY1) or Build Year 2 (BY2) will need to be addressed. BY2 requires monitoring of external entrapment protection sensors per UL 325 - 2016 Standard of Safety. If the gate operator was installed prior to 2016, BY1 may be used. For more information, refer to the gate operator's product manual.

Install Hy5B Vehicle Detectors

Install one Hy5B detector at a time. Each vehicle detector socket is labeled.

1. Turn power OFF in control box.
2. Insert the squared-off end of the plastic standoff through the hole in the Hy5B detector.

NOTE: The plastic standoff "squared-off end" does not fit into the mounting holes of the control box. Double check the orientation of squared-off ends.
3. To minimize excessive flexing, keep each Hy5B perpendicular to the control board as you plug it into the Hy5B socket.
4. Secure the Hy5B by inserting each plastic standoff into the chassis.
5. Place the two wires from the loop into the push terminals of the Hy5B. For ease of installation, the wire gauge should be 20 - 14 AWG. Refer to *Vehicle Loop Sets* on page 72.

SmartDC Control Box

Smart Touch Control Box

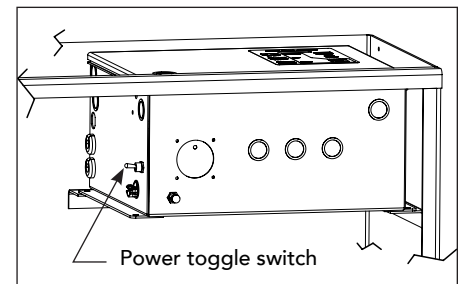
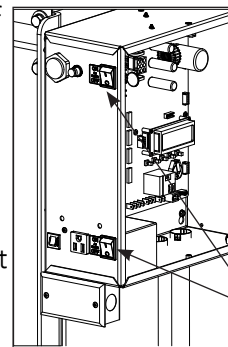

Power switches
Turn off both the DC and AC switches.

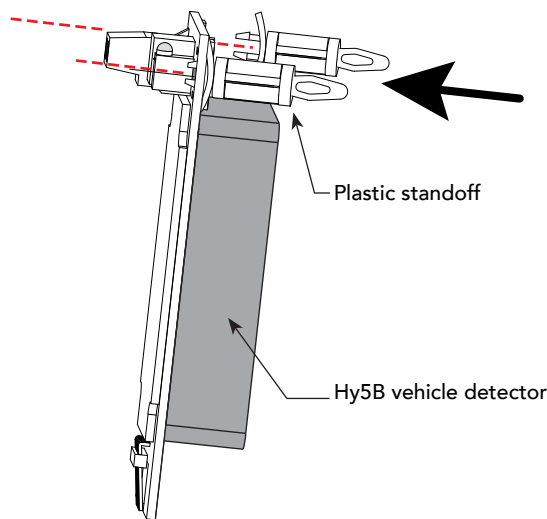

LED Display Status		
LED Activity	Indicates	Condition & Resolution
OFF	Hy5A mode	Emulation mode. Some Hy5B features are unavailable.
GREEN PULSING	Heart beat	Normal operation.
RED ON	Call Mode	Status indicates loop activation in process.
RED FLASHING	View display for more information: <i>Initializing</i> or <i>Faulty loop</i>	If initializing, wait until initialization is complete. If flashing during loop operation, take following steps: 1. Check loop wiring. See <i>Test the Vehicle Loop</i> on page 70. 2. Replace loop. 3. If loop is not at issue, swap out Hy5B vehicle detector with a known operational Hy5B. 4. If necessary, replace Hy5B.

Vehicle Loop Sets				
Loop Type	Installer Menu	Loops Smart DC	Loops Smart Touch	Description
Exit Loop	ELD	EXIT LOOP	FREE EXIT	Opens a fully-closed gate.
Inside Reversing Loop	ILD	INSIDE OBSTRUCTION	INSIDE OBSTR	Connects to the inside reversing loop.
Outside Reversing Loop	OLD	OUTSIDE OBSTRUCTION	OUTSIDE OBSTR	Connects to the outside reversing loop.
Reset/Shadow/Center	SLD/CLD	CENTER LOOP	SHADOW / RESET	Prevents a gate from starting open or closed when a vehicle is in the path of the gate.

- Turn power to the gate operator back ON.
- The Hy5B indicator light flashes red and the following appears.

Smart Touch 7-segment Display	STC (OLED) and Smart DC Displays
<i>i n i t</i>	INITIALIZING

- When the LED on the Hy5B detector stops flashing red, it begins pulsing green which indicates **initialization is complete** and the detector is **ready for use**.

NOTE: If using Hy5A emulation mode, the LED does not flash green, it goes dark. Refer to *LED Display Status* on page 71.

- Press the Reset button. *
When you press Reset, the following occurs:
 - Checks Hy5B loop connections and re-tunes Hy5B to prevent crosstalk
 - Un-installs memory of vehicle detectors physically removed
 - Clears alerts

NOTE: If the Hy5B is unplugged after it is initialized, an alert appears on the display, ALERT 10. If the issue is not resolved, ERROR 3 appears. When faults of this nature occur, the gate operator functions as if the Hy5B is triggered.

* **Best Practice:** When "re-tuning" Hy5B vehicle detectors, verify that the loops are clear before pressing the Reset button.

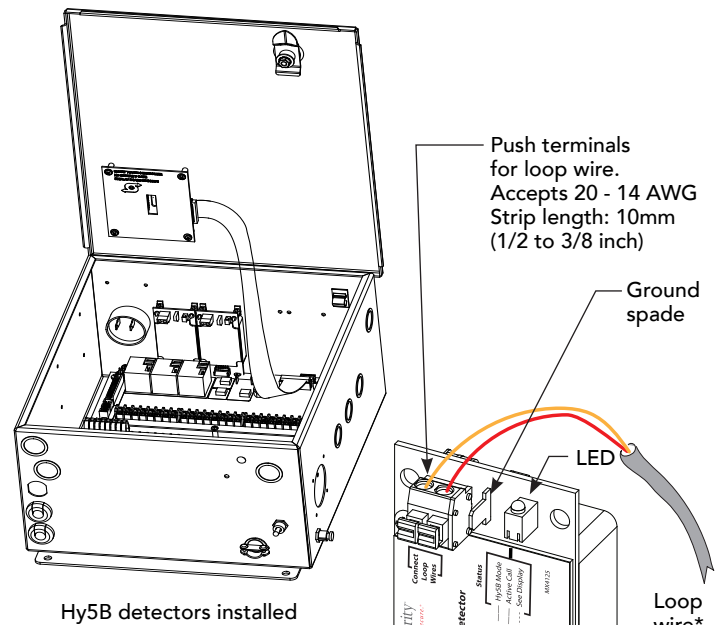

CAUTION

Do not connect Free Exit loop wires to the same Hy5B detector containing obstruction loop wires (reversing loops). You cannot combine Free Exit vehicle detection with reversing loop detection. If you attempt to do so, vehicles crossing over the Free Exit will not be detected.

CAUTION

Do not leave excess loop wire coiled in the control box because it can generate false calls.

For more information, refer to the Hy5B User Guide and additional instructional material found online HySecurity website / Tech Support.

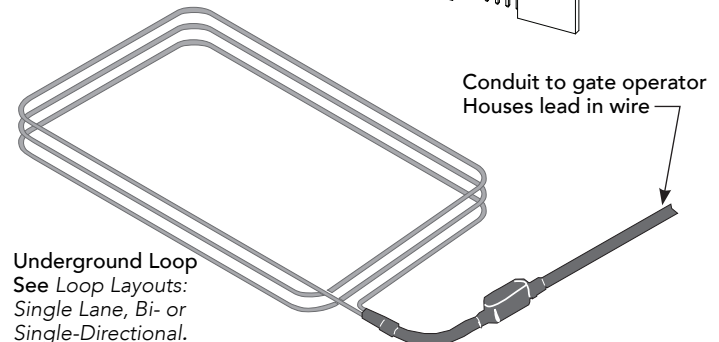

Loops and Hy5B

INSTALLING STANDARD 11-PIN BOX TYPE VEHICLE DETECTORS

If standard 11-pin box type vehicle detectors are to be used, perform the following procedure.

If there is sufficient space, install the sockets in the control box; if not, then install them in a separate external housing. Carefully consider your peripheral connections. Any peripheral device required for safe gate operation should be attached to 24VDC in case of an AC power outage.

NOTE: Box detectors with relays require five times more power than Hy5x detectors. One Hy5x detector draws about 0.005A. Consider Hy5x vehicle detectors for DC and Solar powered sites.

1. Connect 24 Volt power to the detector. Connect Pin No. 1 to a 24VAC or 24VDC terminal and Pin No. 2 to common.
2. Connect output Pin No. 6 to the Common Bus and output Pin No. 5 to one of the four detector terminal inputs (depending upon the detector function required) on the Smart Touch Controller.

If multiple detectors are used, route the power wires and common wire from socket to socket (daisy-chaining) rather than individually running each wire to the same location. The only wires that are separate are the output wire to the Smart Touch Controller and the detector loop input wires.

Always keep the detector loop wires well twisted beyond the area of the loop. The lead in portion sealed in a saw cut does not need to be twisted so long as the wires are encapsulated in loop sealant and cannot move.

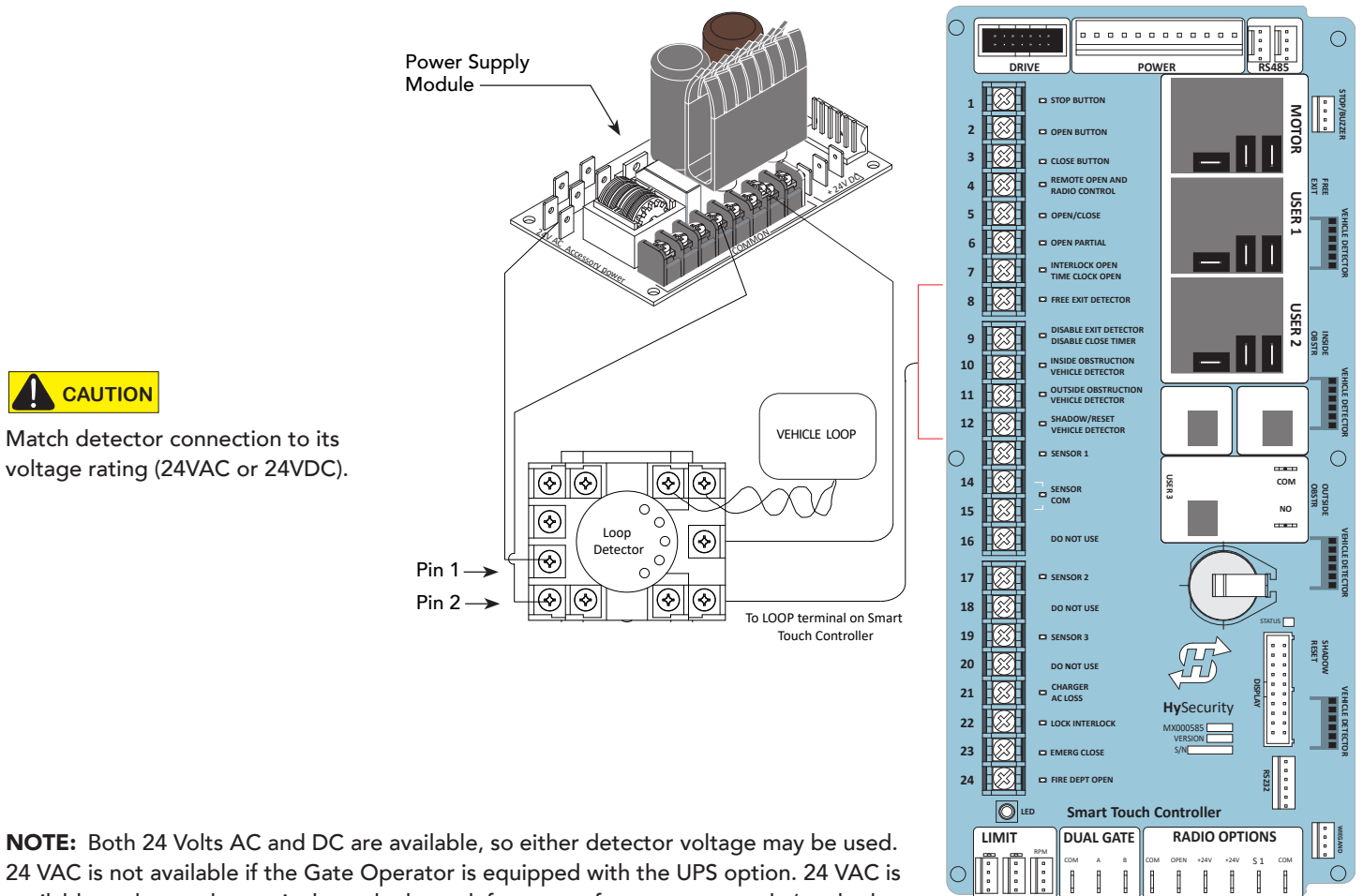

NOTE: Both 24 Volts AC and DC are available, so either detector voltage may be used. 24 VAC is not available if the Gate Operator is equipped with the UPS option. 24 VAC is available at the spade terminals on the lower left corner of our power supply (marked ACC); 24 VDC is available from the Common and the +24 V spade terminals.

LOOP LAYOUTS: SINGLE LANE, BI- OR SINGLE-DIRECTIONAL

For Openings less than 28 Feet

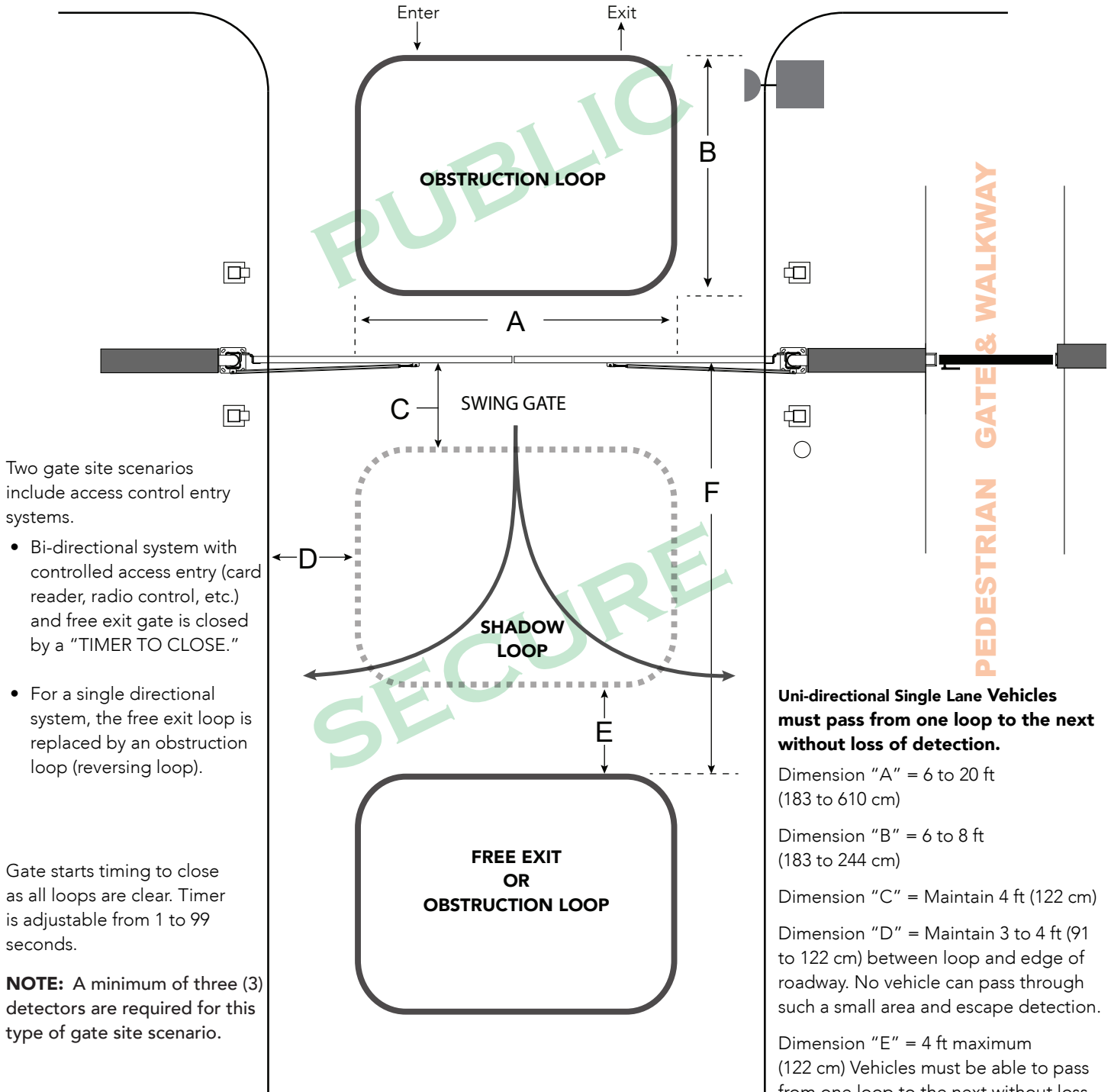

NOTE: A minimum of three (3) detectors are required for this type of gate site scenario.

LOOP LAYOUTS: TWO LANE, BI-DIRECTIONAL

For Openings greater than 28 Feet

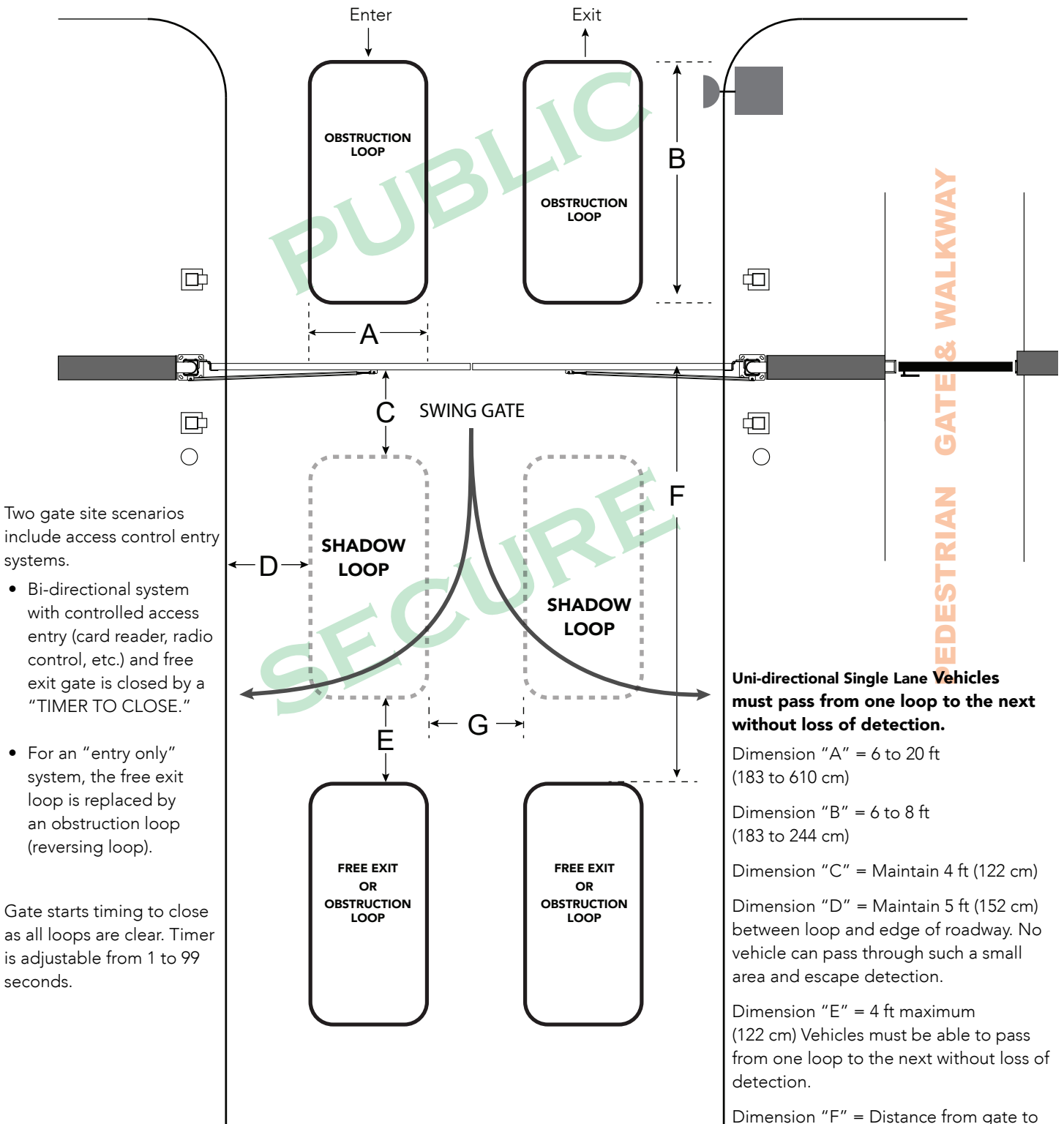

Two gate site scenarios include access control entry systems.

- Bi-directional system with controlled access entry (card reader, radio control, etc.) and free exit gate is closed by a "TIMER TO CLOSE."
- For an "entry only" system, the free exit loop is replaced by an obstruction loop (reversing loop).

Gate starts timing to close as all loops are clear. Timer is adjustable from 1 to 99 seconds.

Uni-directional Single Lane Vehicles must pass from one loop to the next without loss of detection.

Dimension "A" = 6 to 20 ft (183 to 610 cm)

Dimension "B" = 6 to 8 ft (183 to 244 cm)

Dimension "C" = Maintain 4 ft (122 cm)

Dimension "D" = Maintain 5 ft (152 cm) between loop and edge of roadway. No vehicle can pass through such a small area and escape detection.

Dimension "E" = 4 ft maximum (122 cm) Vehicles must be able to pass from one loop to the next without loss of detection.

Dimension "F" = Distance from gate to free exit loop is gate panel length plus 4 ft (122 cm)

Dimension "G" = 4 to 6 ft (122 to 183 cm)

NOTE: A minimum of three (3) detectors are required for this type of gate site scenario.

Page intentionally left blank

Photo Eye Installation

A monitored connection tests for the presence and correct operation of the photo eyes (and other monitored sensors) prior to each gate activation. The monitored connection prevents gate operation if an entrapment protection sensor is missing or any fault is present.

Sensors, such as gate edges and photoelectric beams, must be installed to protect against entrapment. These external entrapment protection sensors are required for the gate installation to be in compliance with the 2016, UL 325 Standard of Safety (6th Edition).

NOTICE: UL 325 Standard of Safety provides the MINIMUM safety standards. Site, gate hardware usage, and other conditions may dictate the use of additional safety designs/components. It is up to the gate system designer and installer to assess appropriate safety design and components above and beyond minimum UL 325 and ASTM F2200 Standard of Safety. Always check your local area codes and comply with all regulations.

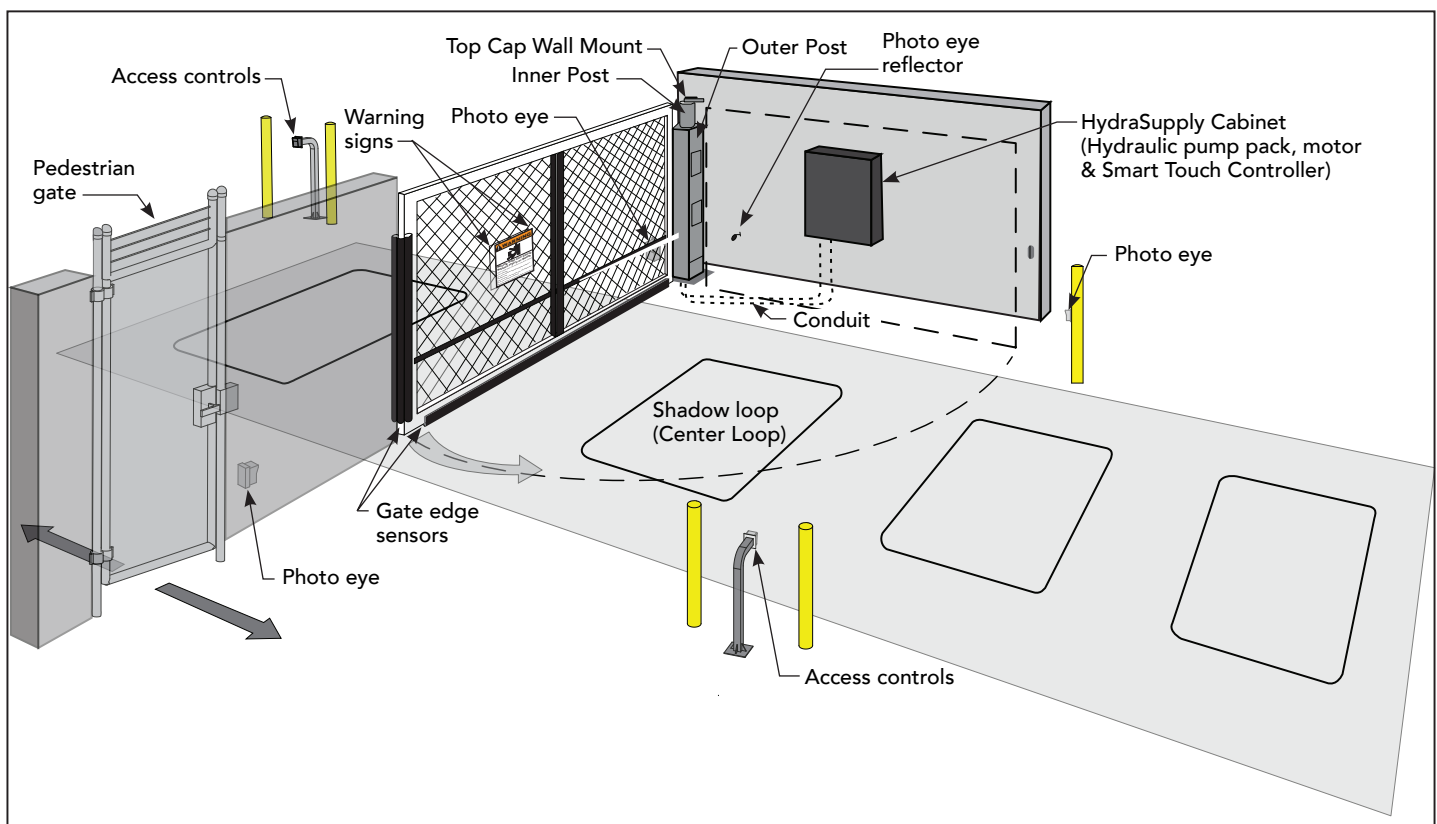

NOTE: To enable fully automatic operation, this gate operator requires a MINIMUM of one external entrapment protection sensor to monitor potential entrapment zones in either the open or close direction of travel.

To learn more about external entrapment *protection* devices or to learn how to temporarily supply power to the sensors that are wired to the gate operator, review *External Entrapment Protection Sensors: What the Installer Needs to Do* on page 27 and *Supply Power to the Sensors* on page 30.

PHOTO EYES (NON-CONTACT) INSTALLATION

Plan to integrate photo eyes (photoelectric sensors) in your site plan. Photo eyes are wired to the Controller and require low voltage conduit to the operator and power supply. Refer to *External Entrapment Protection Sensors monitored by HySecurity Gate Operators* on page iii.

Understand your site requirements and use the layout diagrams available to determine the most appropriate mounting positions for additional photo eyes. The Controller has three sensor inputs.

If there are no other external entrapment protection sensors (typically an edge sensor), then for slide gates, swing gates or any site that must comply with UL 325 monitored entrapment protection regulations, it is highly recommended that at least two photo eyes are installed to serve and reverse the gate in each direction of travel (Open and Close directions).

The two common photoelectric sensor types are thru-beam and retro-reflective; each has its advantages.

- A thru-beam sensor is generally more powerful and able to function more reliably in inclement weather.
- A retro-reflective sensor (generally less reliable in inclement weather or low visibility) provides convenience due to minimal wiring.

NOTE: In an outdoor environment (because of reduced performance), avoid using a retro-reflective sensor to span a distance greater than 24 feet (7.3 meters).

Compatibility

The UL 325 standard requires that a photoelectric sensor be laboratory tested and “recognized” under UL 325. In order to be compatible with all HySecurity operators, a photo eye must be rated to function from 24 VDC source power.

A list of tested and approved external entrapment protection sensors (normally closed contacts) that are compatible with HySecurity gate operators can be found online at the following public site: [Gate Safety for HySecurity Gate Operators](#).

Installation

Install photo eyes according to the following steps.

1. Locate the photo eye in line of sight to the receiver or reflector that is mounted to protect zones of potential entrapment. Refer to site layout on 77.
2. Mount the receivers on the left or right side of the gate operator.
3. Mount the emitters just beyond the travel of the gate.

NOTE: The installation locations are intended for pedestrian detection. If photo eyes are also to be used for vehicular detection, consider (in addition to the low elevation photo eye for cars) installing another photo eye at a height of about 55 inches (140 cm) to detect semi (tractor-trailer) trucks.

Configuration

Configure photo eyes attached to gate operators manufactured in 2016 or beyond according to *Wiring HySecurity Sensors: Smart Touch* on page 109.

NOTE: HySecurity gate operators, manufactured with 2016 (or later) in the serial number, require Normally Closed output sensors. Some manufacturers label an output as N.O. (normally open), when it is actually an N.C. (normally closed) contact. Review *External Entrapment Protection Sensors monitored by HySecurity Gate Operators* on page iii.

If your gate operator is manufactured prior to 2016 and your gate operator is set to Build Year 1, consider the following:

NOTE: To check the Build Year for your gate operator, press the Menu button. The gate status scroll reveals the Build Year. "Build Year Pre-2016" means the gate operator is configured for Build Year 1.

1. If the photo eye has an internal switch for setting Light Operate versus Dark Operate, select Light Operate.
2. If the photo eye has a relay output and has both N.O. and N.C. terminals, some experimentation may be required to determine the proper connection because, when its in the Light Operate mode, the output relay is normally energized and releases when the beam is blocked.
3. If the photo eye has a solid-state output, you must choose a sinking-type connection.



Photo Eye Connections: Smart Touch & Smart DC Controllers



All external entrapment protection sensors must be NC sensor outputs and wired to the SENSOR COM terminal for monitoring and powering purposes. The sensor becomes actively powered when the gate operator's motor runs.

Connect the four wires to the receiver and two wires to the emitter according to the following procedure.

A. Supply power to the sensor.

1. Obtain the +24 Volt source power at one of the three spade-terminals on the STC Power Supply Board.
2. Obtain the 24 Volt Common from SENSOR COM on the Controller.

B. Wire connection so the controller recognizes the sensor device.

3. Obtain the COM from the STC Power Supply Board.
4. Connect the N.C. output to SENSOR 1, 2, or 3.
5. Configure the Installer Menu according to your site sensor set up. Refer to *Table 4: Installer Menu Settings for SENSOR Inputs* on page 29.

NOTE: Jumper between terminals on Photo Eye sensor so you don't need to pull a fourth wire to the Controller terminal. For examples of wiring diagrams, refer to 109. To test Photo Eye, see *Supply Power to the Sensors* on page 30.

Photo Eye Function

If the gate is stationary, a tripped photo eye will prevent the gate from starting in either direction. If tripped while in motion, the standard function is to pause the gate motion and then automatically restart again if the photo eye is clear within five seconds. Optional settings exist in the Installer Menu. Refer to Eye Close Logic and Eye Open Logic (EC and EO) in the *Table 6: Installer Menu* on page 40 for more information.

RETRO-REFLECTIVE PHOTO EYE SYSTEMS

Correct installation and alignment of a retro-reflective photo eye and its reflector is important for trouble free performance. Any system operating at a range greater than 16 feet is more prone to false triggering due to dirty optics, condensation or poor weather. If care is taken in the initial mounting and alignment of the 3-inch reflector, the chance of problems is greatly reduced.

NOTE: Use only through beam photo eyes for a distances greater than 24 feet because the function of a retro-reflective photo eye will be too unreliable.

Taking steps to protect the photo eye and the reflector from being exposed to fog and being absolutely certain the photo eye is perfectly aligned will greatly reduce any false triggering of the system. The ideal mounting of a retro-reflective photo eye is inside an enclosure.

Ideally the reflector mount suspends the reflector inside a 12-inch long piece of 3-inch PVC conduit. Cut the opening of the PVC conduit at a 45-degree angle to act as a drip shield. Hold the reflector against the backside of the PVC conduit by attaching a 3-inch male connector. **DO NOT** cement the connector as doing so makes it difficult to reach the reflector for future cleaning.

To create a mounting base, attach a 3-inch aluminum flange (for example, an electric meter hub) to the connector. This whole package can be mounted to any flat surface.

Locate the reflector in the center of the invisible beam of infrared light to achieve the most sensitive alignment.

The beam center is determined by the following test:

1. While holding the reflector in your hand, slowly raise it until the beam is no longer returned and the photo eye trips.
2. Mark this maximum height.
3. Lower your hand and determine the lower limit of the infrared beam by watching for the trip point. Mark this position.
4. Repeat the same procedure for left and right at the center elevation of the beam.

When the four parameters are marked, either:

- Mount the reflector in the center of the area outlined

or

- Realign the eye for the position of the reflector.

NOTE: If the photo eye is realigned, be sure to perform the centering test again to verify that the reflector is truly in the center.

USING PHOTO EYE SENSORS INSTEAD OF VEHICLE LOOPS

Some site conditions (for example, dirt or gravel roads) may warrant use of photo eye sensors for vehicle detection. In this type of application, the photo eye pair is connected to vehicle loop terminals on the Controller.

NOTE: A pair of photo eye sensors, used in place of vehicle loops and wired to vehicle loop terminals on the Controller, does not satisfy UL 325 Standard of Safety for “monitored” external entrapment protection. To understand external entrapment protection and how HySecurity equipment monitors sensors, refer to the section titled *Entrapment Protection* on page 25.

Smart Touch Controller

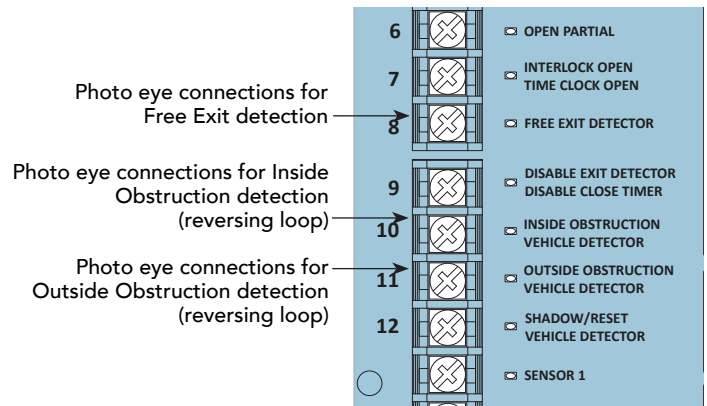

Photo Eye sensor terminal connections when PE sensors used in place of vehicle loops

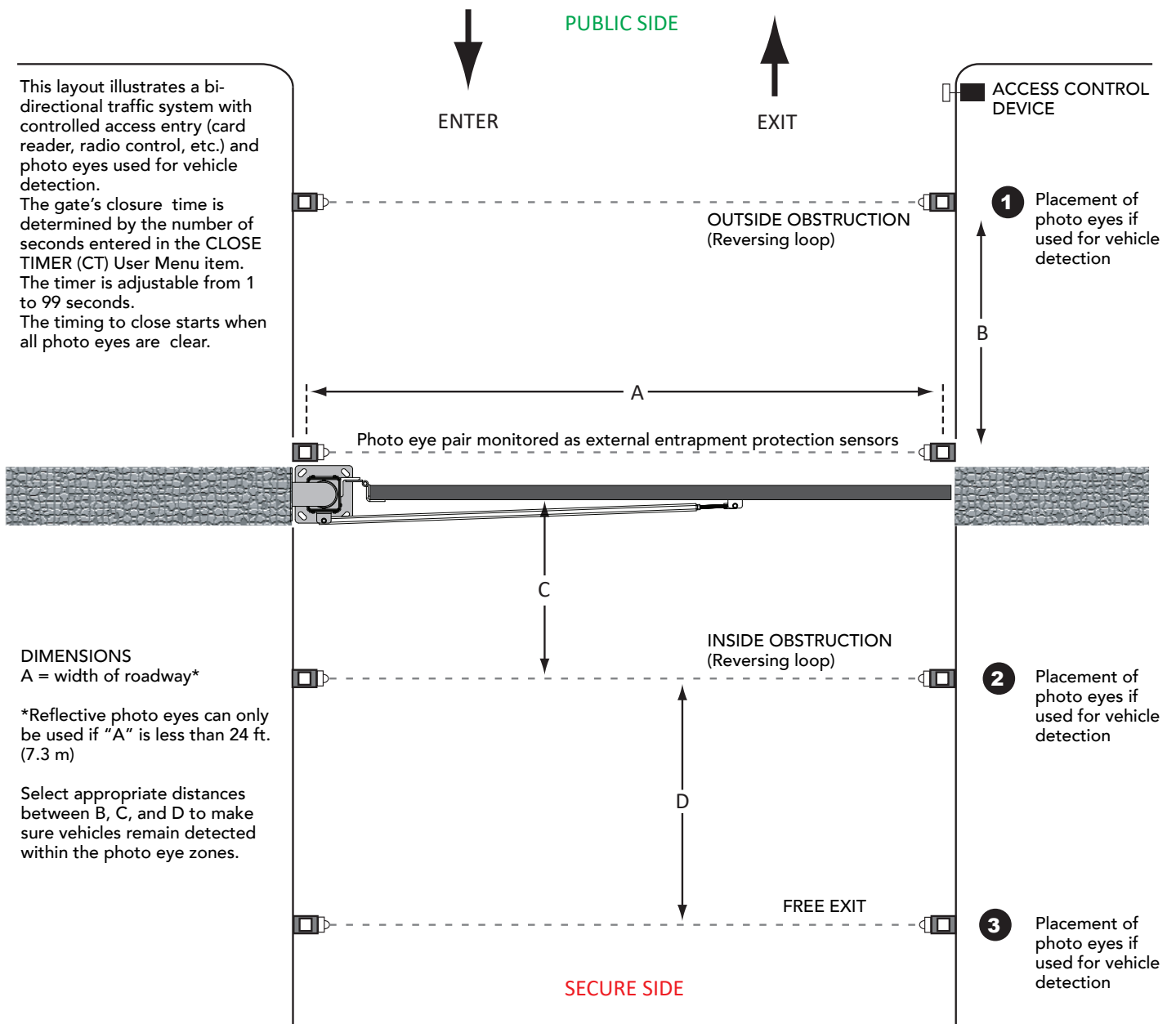
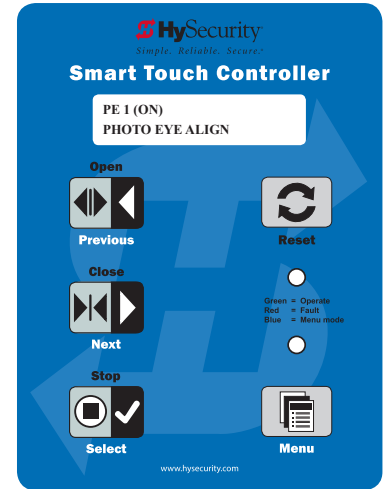

PHOTO EYE ALIGNMENT FEATURE

Most photo eyes require careful optical alignment in order to aim the emitter beam to the center of the receiver or reflector. In order to avoid false triggering, it is important to carefully align the system.

Align the photo eyes using this feature by taking the following steps:

1. Access the User Menu and select PE.
To access the User Menu, press the Menu button twice. For a refresher on using the Menu Mode navigational buttons, refer to the chart below.
2. Press NEXT and continue to press NEXT until PE 0 (OFF) appears.
3. Press SELECT.
PE characters begin blinking.
4. To turn ON photo eye alignment and temporarily power the sensors, press NEXT so PE 1 (ON) appears.
5. Press SELECT.
PE stops blinking.
6. Move the photo eyes (up/down, side to side) to align the emitter beam.



Audible Chirp	Beam Aligned ??
One	No
Two	Yes

7. When the buzzer chirps twice, indicating the photo eyes are aligned, set the next photo eye (if the site has one) and continue the process until all photo eyes are aligned.
8. Press MENU to exit Menu Mode and return to Run Mode.
9. Move the gate with an open or close command. When a limit is triggered, the User Menu item PE resets to zero (OFF).

NOTE: To cover the potential entrapment areas, mount photo eyes preferably within 5 inches (13 cm) of the gate face. See *Installation* on page 78. To learn how to temporarily power external entrapment protection sensors using the PE User Menu item, see *Supply Power to the Sensors* on page 30.

Smart Touch Controller: Menu Mode Navigation Buttons

To access Menu mode	To change menu item appearing in the display	To navigate through the menu item selections	To choose what item appears on the display	To navigate between menu items
Press the Menu button twice.	Press Select. Two left characters blink.	Press Next or Previous. Continue pressing Next to view all selections.	Press Select. Blinking characters become static.	Press Next or Previous. Advance - press Next Previous - press Previous

Installing Gate Edge Sensors

A monitored connection tests for the presence and correct operation of the gate edge sensors (and other monitored sensors) prior to gate activation. The monitored connection prevents gate operation if a sensor is missing or any fault is present.

Sensors, such as gate edges and photoelectric beams, must be installed to protect against entrapment. These external entrapment protection sensors are required for the gate installation to be in compliance with the 2016, UL 325 Standard of Safety (6th Edition).

NOTICE: UL 325 Standard of Safety provides the MINIMUM safety standards. Site, gate hardware usage, and other conditions may dictate the use of additional safety designs/components. It is up to the gate system designer and installer to assess appropriate safety design and components above and beyond minimum UL 325 and ASTM F2200 Standard of Safety. Always check your local area codes and comply with all regulations.

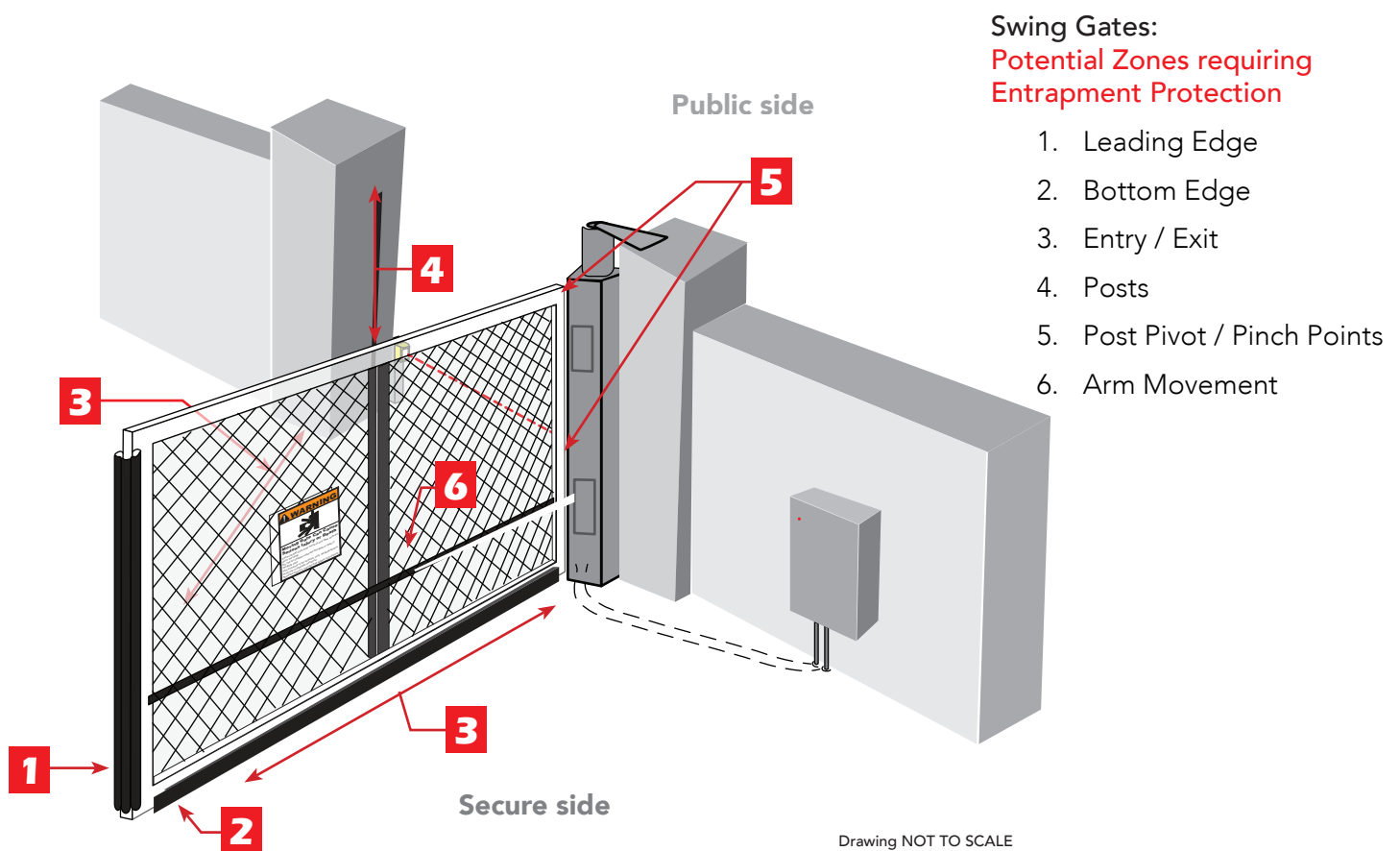

Assess your gate site for the most appropriate placement of edge sensors. Plan to integrate contact (gate edge) and non-contact (photo eyes) sensors in your site plan. Sensors are wired to the Controller and require low voltage conduit to the operator and power supply. Refer to *External Entrapment Protection Sensors monitored by HySecurity Gate Operators* on page iii.

To enable fully automatic operation, this gate operator requires a MINIMUM of one external entrapment protection sensor to monitor potential entrapment zones in either the open or close direction of travel.

Compatibility

The UL 325 Standard of Safety requires that a photoelectric sensor be laboratory tested and “recognized” under UL 325. In order to be compatible with all HySecurity gate operators, a photo eye must be rated to function from 24 VDC source power.

A list of tested and approved external entrapment protection sensors (normally closed contacts) that are compatible with HySecurity gate operators can be found online at the following public site: [Gate Safety for HySecurity Gate Operators](#).

Installation

NOTE: Follow the manufacturer’s installation and assembly instructions to properly mount the sensor. Wiring diagrams for several sensor devices are found in *Wiring HySecurity Sensors: Smart Touch* on page 109.

HySecurity gates monitor normally closed (NC) sensors. Wire the NC sensors to SENSOR input terminals (SENSOR 1, SENSOR 2, or SENSOR 3) on the Smart Touch Controller and set the Installer Menu item S1, S2, or S3 to the appropriate setting for the area being monitored.

When using wired edge sensors, the wired edge must be connected to an interface module with an NC output. Miller Edge® has marked UL 325 - 2016 compliant edge sensors with blue electrical tape on the output wire. These edge sensors have a 10k Ω resistor that connects to an interface module. The interface module provides the NC output for monitoring purposes. Refer to *Wiring HySecurity Sensors: Smart Touch* on page 109.

For wireless edge sensors, no interface module is required. Wireless edge sensors need the wireless gate links which include a transmitter and receiver. HySecurity has created kits for all-inclusive shipment.

NOTE: The installation locations are intended for pedestrian detection and safety. The potential zones requiring entrapment protection are areas that need to be protected for pedestrian safety.

Gate Edge Function

If the gate is stationary, a tripped gate edge sensor will prevent the gate from starting in either direction. If tripped while in motion, the standard function is to stop the gate movement and, if tripped while closing, automatically re-open fully. An optional setting in the Installer Menu will cause a 2 second reversal if triggered while closing. Refer to *Table 6: Installer Menu* on page 40 for more information.



Example: Wired gate edges used with 10K Ω (8.2K Ω) resistor



Example: Wireless gate link (transmitter & receiver) used with wireless gate edges

Troubleshooting

The Smart Touch Controller reports system malfunctions using three simultaneously occurring methods:

- Codes presented on its display (alert, fault or error)
- Activation of a buzzer which emits a series of chirps at defined intervals
- Stop gate travel (and/or reverse direction of travel)

Refer to *Table 8: Troubleshooting Codes* on page 86 for details concerning identification and description of Alerts, Faults and Errors.

Overriding a tripped sensor or fault condition on a HySecurity gate operator with monitored entrapment sensors requires a 2-step process:

- Press Open or Close momentarily. Audible beeps in quick succession indicate tripped sensors or fault conditions.
- Within 5 seconds of hearing the beeps, apply constant hold pressure to override the tripped sensor or fault. The gate operator runs while pressure is maintained to actuating device (examples include, Push button Open, Push button Close, Open Partial or Keypad Open/Close), or a limit is reached, or another sensor trips.

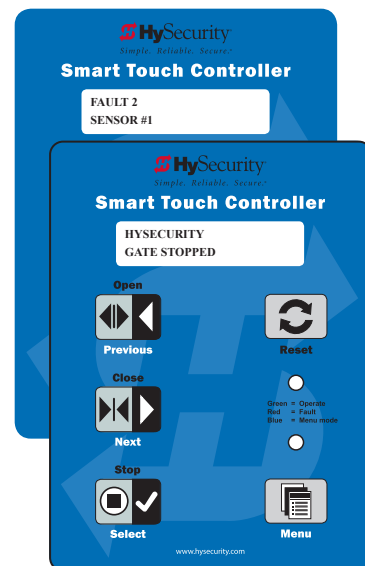

NOTE: A qualified technician may troubleshoot the operator with the aid of the information and procedures that follow. If it is necessary to call a distributor for assistance, be sure to have the model and serial numbers available. Other helpful information is the job name, approximate installation date, and service records of any recently-performed maintenance work.

TIP: On AC-powered gate operators, the active status of each input on the Smart Touch Controller is indicated by its associated lit LED. However, an exception exists in the case of external entrapment protection sensors. The LEDs next to the sensor connections will be lit when no power is being applied. For more information, refer to *Supply Power to the Sensors* on page 30.

SYSTEM DIAGNOSTIC MESSAGES

Code	Priority	How to clear
ALERT	Low	Enter new command such as Open or Close.
FAULT	Medium	Press the Stop or Reset button
ERROR	High Serious issue that may require technical service.	Errors can only be cleared by pushing the Reset button or cycling power.

NOTE: The green LED near the coin-sized battery on the Smart Touch Controller is the “heartbeat” of the processor. This LED flashes continuously and at a constant rate when the system is operating normally. When a fault, error, or alert occurs, it turns red.

The Smart Touch Controller maintains self-diagnostics. Specific codes appear on the display and the Audio Alert buzzer emits distinctive chirping sounds. Any Alert, Fault, or Error is logged into memory and stamped with the date and time. These diagnostic messages can be retrieved for analysis purposes via optional S.T.A.R.T. software and a PC laptop.

NOTE: S.T.A.R.T. configuration and diagnostic software is available at no charge.

Table 8: Troubleshooting Codes

Type	Alert/Fault/Error Display	Buzzer Chirp Sequence	Possible Cause & Suggested Corrective Action
ALERT	HYSECURITY Entrapment Mode ENTR	2 chirps per second every 2s while control input is active	An IES has been tripped twice within a specific period of time. Check the gate site for obstructions and clear the gate area. To return to run mode operation, press the Reset button.
ALERT	HYSECURITY Safe Mode SAFE	2 chirps once when in Safe Mode	A gate "edge" or IES has been tripped or the operator has exited entrapment mode. Refer to the description above. NOTE: Gate will operate, if it receives a RUN command.
ALERT	Low 24VDC DC BUSS < 21V	No chirps; LCD flashes for 1s every 5s	Only occurs in DC powered operators.
ALERT	Critical Low Power	No chirps; LCD steady and controls disabled	The system monitors the 24V control voltage in lieu of line voltage. Low incoming line voltage will cause low control voltage. Verify that the control transformer is connected properly, (white – not used, red for 208V, orange for 230V and blue for 460 V). As the motor starts, check the line voltage with a meter that has min/max hold capability. If the line voltage drops more than 10% below nominal (187 on 208 VAC, 207 on 230 VAC, or 416 on 460 VAC) the voltage is dropping too much and must be corrected. Generally, this requires larger wire size. On 3-Phase operators, check each leg to ground to make sure it is balanced. If the line voltage is not dropping below these limits, check the 24V AC and DC power at the power supply. Voltages less than 20V indicate an overloaded or failing transformer or power supply board. Remove the loads until the fault is found.
ALERT	Dead Battery DC BUSS < 21V	3 chirps upon any operating command entry	DC operators only. Appears when the 24 VDC power drops too low, disabling the operator which helps prevent damage to the batteries from excessive discharge. Verify the AC power is present at the charger, the charger is on and charging (Red LED is illuminated). The charger should shut off (Green LED) when the batteries charge to 29.0 VDC. If the batteries cannot "hold a charge" replace them.
ALERT	No AC POWER	Chirps once whenever the gate reaches the close limit	AC power is shut off at the source (breaker) or is not connected. The operator's AC power switch is turned off or the main circuit breaker has tripped. <ul style="list-style-type: none"> • Have a licensed electrician check the wiring. • Connect AC power to the operator. • Reset circuit breaker at the electrical panel. • Reset the operator circuit breaker. • Turn AC power switch on.
ALERT	!ACTION BLOCKED PHOTO EYE CLOSE PEC	5 chirps indicating that the command cannot be initiated	Photo eye is not recognized as active. <ul style="list-style-type: none"> • Clear photo eye path • Realign photo eye. Refer to <i>Photo Eye Alignment Feature</i> on page 82. • Replace photo eye battery • Check N.C. wiring (verify wires are not disconnected or shorted) • Review wiring diagrams. Especially path to SENSOR COM • Make sure SENSOR settings S1, S2, and S3 are correctly assigned. Refer to <i>External Entrapment Protection Sensors: What the Installer Needs to Do</i> on page 27.
ALERT	!ACTION BLOCKED PHOTO EYE OPEN PEO	5 chirps indicating that the command cannot be initiated	Photo eye is not recognized as active. <ul style="list-style-type: none"> • Clear photo eye path • Realign photo eye. Refer to <i>Photo Eye Alignment Feature</i> on page 82. • Replace photo eye battery • Check N.C. wiring (verify wires are not disconnected or shorted) • Review wiring diagrams. Especially path to SENSOR COM • Make sure SENSOR settings S1, S2, and S3 are correctly assigned. Refer to <i>External Entrapment Protection Sensors: What the Installer Needs to Do</i> on page 27.

Type	Alert/Fault/Error Display	Buzzer Chirp Sequence	Possible Cause & Suggested Corrective Action
ALERT	IACTION BLOCKED GATE EDGE (Open or Close) GEO	5 chirps indicating that the command cannot be initiated	Operator received command to run open, but movement is prevented. Gate edge blocked or disconnected and causes operator to enter SAFE mode. Gate edge is not recognized as active. <ul style="list-style-type: none"> • Replace sensor batteries • If using Miller Monitored Edge Link, be aware. Issues with radio interference cause false trips. Placing the antenna high and reducing environmental "noise" is critical to proper wireless transmission. Avoid placing the receiver sets within 100 feet of each other as crosstalk may occur. Use receivers & transmitters Version 1.02 or later. • Verify wired edges are using a gate edge converter-type module. Miller Edges must have a wire with blue tape. The blue tape indicates that a resistor is built in. • Check N.C. wiring (verify wires are not disconnected or shorted) • Review wiring diagrams. Especially path to SENSOR COM • Make sure SENSOR settings S1, S2, and S3 are correctly assigned. Refer to <i>External Entrapment Protection Sensors: What the Installer Needs to Do on page 27.</i>
ALERT	ALERT 1 Forced Open	2 pulses per second for 30s	Set FA 1 in the User Menu, to enable this option. The operator will attempt to re-close itself if forced off the close limit switch, the buzzer sounds for 30 seconds. Check for attempted unauthorized access, external pressure trying to open the gate or a mis-adjusted/failed closed limit switch.
ALERT	ALERT 2 Drift Closed	2 pulses per second for 10 seconds	Set F0 1 in the User Menu, to enable this option. If a gate should begin to drift closed it automatically reopens (for up to 4s) once it leaves the full open limit. If it is not back on the open limit at the end of 4s, an audible alert occurs. Check for misadjusted/failed open limit, misadjusted brake valve, outside pressure (wind, fallen trees) or cylinder leakage affecting drift issue.
ALERT	ALERT 3 EXCESS DRIFT	Gate drift in transit - Advisory only. The alert appears and is being prevented from re-opening.	Will self-clear after an open or close input.
ALERT	ALERT 4 THERMAL Overload	2 chirps per second every 15 seconds	The motor windings have exceeded a preset temperature generally due to excessive current. Verify: <ul style="list-style-type: none"> • The motor connections are correct for the supply voltage • Running voltage is within 10% of rated • High starting currents last 2 seconds or less; if not and voltage during start is correct, on 1Ø units you can replace the start switch/capacitor • Motor running current (all phases) is at or below rated (at normal pressures) • When the motor is cool, open the motor connection box, disconnect the 2 small wires going into the motor, and use an ohmmeter to check continuity of these wires. They should be a short circuit; if not, replace the motor.
ALERT	ALERT 5 Both Lim ACTIVE	2 chirps per second every 15 seconds	The STC is seeing both limits tripped at the same time. For HydraWedge SM50, check for a stuck limit switch or debris caught in limit switch area and repair any wiring issues. On electromechanical gate operators and StrongArmCrash, reset the limits through the Installer Menu item, LL Learn Limits.
ALERT	ALERT 6 Lim not released	2 chirps per second every 15 seconds	Is the pump developing pressure? Are the brake valves set properly? Is there hardware holding the gate? <ul style="list-style-type: none"> • Check fluid levels and brake valve settings.
ALERT	ALERT 7 Freq SHIFT FAULT	2 chirps per second every 15 seconds	Hy5x detector has detected a frequency change outside the normal range. Check the loops and the integrity of the loop installation.
ALERT	ALERT 8 LOOP SHORTED	2 chirps per second every 15 seconds	Hy5x detector has detected a short circuit in the loop. Temporarily switch detector to be sure the loop is at fault and then repair it.
ALERT	ALERT 9 LOOP OPEN	2 chirps per second every 15 seconds	Hy5x detector has sensed that the loop has become an open circuit. Check all connections and/or use an ohmmeter to find out where the break is.
ALERT	ALERT 10 I2C BUS ERROR	2 chirps per second every 15 seconds	Communication issue between the Hy5x and the Smart Touch Controller; reset and try again. Replace the Hy5x if the problem continues.

Type	Alert/Fault/Error Display	Buzzer Chirp Sequence	Possible Cause & Suggested Corrective Action
ALERT	ALERT 11 DETECTOR FAULT	2 chirps per second every 15 seconds	Unknown fault; perform the megaohm test and fix the loop if necessary. Replace the Hy5x if the problem continues.
ALERT	ALERT 12 ON TOO LONG	2 chirps per second every 15 seconds	The detector believes there has been a vehicle on the loop for more than 5 minutes. <ul style="list-style-type: none"> • Is there something metal on (or near) the loop? • Is the sensitivity adjustment set too high? • Is the roadway solid? If the underground loop moves it will give false readings. • There may be a problem with the loop itself. Check with a megohm meter. New loops should read 100 mega-ohms or better, between 50 and 100 operation are generally OK, below 50 mega-ohms install a new loop.
ALERT	ALERT 13 STIFF GATE	2 chirps per second every 15 seconds	The STC detects a gate that, over time, is requiring more power to move it. Usually caused by degrading gate hardware or debris in a slide gate track. This alert appears in the history log. It does not affect opening or closing the gate. <ul style="list-style-type: none"> • Check and correct gate hardware as required. • Check motor brushes for excessive wear.
ALERT	ALERT 14 STUCK GATE	2 chirps per second every 15 seconds	The STC detects that it cannot move the gate because of possible broken gate hardware or ice/snow buildup. <ul style="list-style-type: none"> • Manually move the gate. Verify that it moves easily and is unobstructed throughout gate travel. • Check and correct gate hardware, as required.
ALERT	ALERT 17 BAD COIN BATTERY	2 chirps per second every 15 seconds	Turn off AC power and replace the 3V coin battery that controls the internal clock. Use a CR2032 coin battery.
ALERT	ALERT 18 CHANGE BATTERY	1 chirp a minute	Batteries are not taking a charge. The STC has detected that the 24VDC UPS batteries need to be replaced. NOTE: The buzzer will chirp every minute until the UPS batteries are replaced.
ALERT	ALERT 19 FALSE SLOWDOWN	2 chirps per second every 15 seconds	Appears only on gate operators with VFD. Slowdown switch tripped and released (less than 1 second) in middle of run. Check for loose wires, limits and misaligned rails or limit ramps.
ALERT	ALERT 20 EXT LOCK FAILED	2 chirps per second every 15 seconds	An interlock contact is closed, indicating that the gate latch (lock) is engaged, preventing the operator from starting. Check the interlock terminal and wiring.
ALERT	ALERT 21 DRIVE TRIP	2 chirps per second every 15 seconds	Gate travel will not occur until the alert is cleared. Any open or close command resets the alert and starts the gate moving, unless the VFD is experiencing a fatal error. If you cannot clear the error alert by pressing the open or close button, contact HySecurity.
ALERT	ALERT 22 INTLOCK FAILURE	2 chirps per second every 3 seconds	Appears when the RS-485 communication connection is lost for more than 5s between interlocked (dual gate) or sequenced gate operators. Check cable connections and wiring. Make sure both operators are working properly and have compatible software versions. The alert auto clears when communication between the two operators is restored. If the operator on site is a singular gate and the display code ALERT 22 appears, access the Installer Menu. Verify the Installer Menu items: DG (Dual gate) and SG (Sequential gate) are both set to zero.

Type	Alert/Fault/Error Display	Buzzer Chirp Sequence	Possible Cause & Suggested Corrective Action
ALERT	ALERT 24 EXT RELAY FAULT	2 chirps per second every 15 seconds	The Hy8Relay (extended relay module) is not being recognized. Alert noted in diagnostic log. Check the wiring: <ul style="list-style-type: none"> • Make sure the slide switch on the side of the extended relay module is set at "Normal." • (Y) Data + is connected to "A" DUAL GATE. • (G) DATA - is connected to "B" DUAL GATE. • Connector cable (4-pin) attaches to RS-485. If Hy8Relay module is not connected, access the Installer Menu. Check that the extended user relays are set to zero. STC = R4 to RB (7-segment display) SDC = R3 to R9 (32 character display) STC = R4 to R11 (32 character display)
ALERT	ALERT 25	N/A	HyNet Only. The HyNet coin battery is dying. Turn off AC power to the HyNet and replace the existing coin battery with a CR1220 coin battery. Turn On power to the HyNet. The ALERT should reset and disappear from the display.
ALERT	ALERT 26	2 chirps per second every 15 seconds	Only appears in HydraSupply XL. When valve closures or IES trips do not detect limit switch triggers or, if the appropriate limit switch is not reached within 10s of receiving an operate command and the pressure switch is open, then Alert 26 – Lim Not Reached will be declared. If the barrier moves by pressing an operate command, the display resets and the ALERT 26 timer rearms.
ALERT	ALERT 27	2 chirps per second every 15 seconds	Only appears in HydraSupply XL. The fluid level in the accumulator is low. An EFO may not trigger properly. Have service personnel check the HydraSupply XL. Cycle the barrier and watch the pressure gauge. If the pressure is low, the blocking plate does not rise or the motor times out, check hoses for leaks. If necessary, recharge the accumulator. While ALERT 27 appears on the display, a renewed close command will attempt to run the barrier, but the alert will not clear unless the close limit is reached or a reset is pressed.
ELD OOLD IOLD SLD RLD	"Vehicle Loop Detectors"		Appears in sequence with another display code which pertains to the loop issue. Refer to the other display code for more information. ELD = Exit Loop Detector OOLD = Outside Obstruction Loop Detector IOLD = Inside Obstruction Loop Detector SLD = Shadow Loop Detector RLD = Reset Loop Detector
FAULT	FAULT 1 MOTOR RUN TIME	1 chirp once every 15 seconds	The STC has detected the motor is on longer than the maximum run time selected. Check and replace drive belt on applicable gate operators. Increase Max Run Timer in the Installer Menu.
FAULT	FAULT 2 FAL2	2 chirps per second once per minute	"Monitored" means the Controller must see the photo eye N.C. contact change from open to close after receiving the command to run, but before starting the motor. FAULT 2 indicates the controller did not see this sequence when the gate received a run command. Check the wiring. Refer to the wiring diagram associated with the attached sensor. See <i>Wiring HySecurity Sensors: Smart Touch</i> on page 109. Be sure the eye "common" wire is wired properly to the SENSOR COM terminal.
FAULT	FAULT 3 LOW VOLTAGE SAG	2 chirps per second once per minute	The 24V control voltage is monitored in lieu of line voltage. Low incoming line voltage will cause low control voltage. Verify that the control transformer is connected properly, (white – not used, red for 208V, orange for 230V and blue for 460V). Check the line voltage as the motor starts with a meter that has min/max hold capability. If the line voltage drops more than 10% below nominal (187 on 208VAC, 207 on 230VAC, or 416 on 460VAC) the voltage is dropping too low and must be corrected. This condition is often caused by loose connections or the wire size being too small. If the wire is too small, it must be replaced.

Type	Alert/Fault/Error Display	Buzzer Chirp Sequence	Possible Cause & Suggested Corrective Action
FAULT	FAULT 5 LIMIT FAILED	2 chirps per second once per minute	50VF series only. Not applicable for StrongArm M30/M50. Slow down to stop limit took too long. Possible bad limit switch. <ul style="list-style-type: none"> • Verify limits and placement of slow down limit ramps. • With drive wheels clamped, test Open (GATE OPENING appears on display). Test Close (GATE CLOSING appears on display).
FAULT	FAULT 14 STUCK GATE	2 chirps per second once per minute	The STC has tried 3 times to overcome a stuck gate. The gate is non-operational while this fault is triggered. Caused by broken gate hardware or ice/snow buildup. Check and correct gate hardware as required. Press RESET to clear fault.
ERROR	ERROR 1 Direction Error	3 chirps per second once per minute	Close Limit tripped after running Open or Open Limit tripped after running Closed. Assess cables and wire connections. <ul style="list-style-type: none"> • Make sure wires are connected to the proper terminals. Make sure gate handing is appropriate. • Swap connections of hydraulic hoses, if necessary. Refer to <i>Gate Handing</i> on page 22.
ERROR	ERROR 2 IES Disconnect	3 chirps per second once per minute	<ul style="list-style-type: none"> • The IES sensor could be bad, check to see that the NC contact is intact. • Check that you have the most current sensor; visit our website and view the technical bulletins in the Tech Support area. The sensor wire could be loose; you may want to tighten the female connectors with some pliers. • Verify the version of the software by pressing the Reset button. The software version appears on the display. Make a note of it. The software version should be h4.50 or h5.50 (or later). • If necessary, update the software using a PC laptop and S.T.A.R.T.
ERROR	ERROR 3 HY5 COMM ERROR	3 chirps per second once per minute	One or more detectors are not communicating properly. Remove detectors, reset the controller, and re-install detectors one at a time until faulty detector or loop is found.
ERROR	ERROR 4 DUAL GATE	3 chirps per second once per minute	Indicates a problem with the communication between the two gate operators in a bi-parting (primary/secondary) gate system. Check the software versions by pressing Reset or cycling power. The version number flashes on the display (examples, h4.54 or h5.56). The software versions on the Primary and Secondary gate should be the same. If not, upload current software version using S.T.A.R.T. and a PC laptop computer. <ul style="list-style-type: none"> • Verify the Installer Menu item DG (DUAL GATE) is set to DG2 in Primary and set to DG1 in Secondary gate operator. • Make sure the wires are twisted and shielded. See <i>Dual Gate Wiring Connections</i> on page 62. • Be sure the low voltage wire runs, which include the bi-parting gate communication wires, are separate from any high voltage wires runs. Interference occurs if wire runs are mixed or too close to each other. The error automatically clears when the communication fault is resolved.
ERROR	ERROR 6 DRIVE BOARD	3 chirps per second once per minute	Internal error between the STC board and the VFD. Check cable connections and wiring. Make sure both units are working properly.
ERROR	ERROR 7 MENU CHECKSUM ERR7	3 chirps per second once per minute	Contact HySecurity.
ERROR	ERROR 8 RPM SENSOR	3 chirps per second once per minute	Check wiring from the hydraulic cylinder to the STC.
ERROR	ERROR 9 BATT DISCONNECT	3 chirps per second once per minute	Only applies to DC Power Supply connection. Contact HySecurity.

Type	Alert/Fault/Error Display	Buzzer Chirp Sequence	Possible Cause & Suggested Corrective Action
ERROR	ERROR 10 SLOWDOWN SWITCH	3 chirps per second once per minute	VFD only. The operator tripped the fully Open or Close limit before the Slowdown limit tripped. Check: Slowdown limit wiring and adjustment Adjustment of the limit ramps to verify that the limit switch is being tripped. Manually trip the slowdown limit. OPEN SLOWDOWN or CLOSE SLOWDOWN should appear on the display which indicates that it is working properly.
FAIL	FAIL Program Data Err FAIL	3 chirps per second once per minute	Try turning off the power to the operator and having the customer re-seat all of the various connectors and cables. Upload the latest software release. If the fail does not go away, contact Technical Support.

ACCESS THE EVENT LOG THROUGH THE USER MENU

NOTE: While you are viewing the event log, the gate operator is in Menu mode and cannot run open or close.

- To enter the User Menu, press the Menu key twice.
 - Press Next and scroll until "LG 0 (OFF)" appears in the display.
 - Press Select. LG blinks.
 - Press Next to change the number to 1,
LG 1 (ON)
VIEW EVENT LOG
 - Press Select. The most recent event recorded in the log appears.
 - To scroll through the event log, press Next or Prev.
- NOTE:** Hold down Next or Prev to scroll quickly toward the top or bottom of the event log.
- To exit, press Menu. The display resets to LG 0 (OFF).
 - Press Menu again to exit the User Menu and return to Run/Program mode.



Month / Day	Time (HH:MM)	Event Type
03/17	15:27	ALE5
Description: ALERT 5: BOTH LIMITS TRIPPED		

NOTE: Over 300 events can be recorded before the software begins overwriting the existing log history.

The event log is also accessible through S.T.A.R.T. software with the use of a PC laptop and interface cable. Refer to the [S.T.A.R.T. User Guide](#).

ELECTRICAL ISSUES

A general set of troubleshooting procedures are provided in the following paragraphs. Use a voltmeter to take the measurements described in the steps. If at any point in the process, a result different than what's expected occurs, stop and identify the problem.

AC-Powered Gate Operators

PROBLEM 1: Pushed the OPEN and CLOSE button, but the motor is not running.

1. Verify the incoming voltage and phase at the incoming power terminals matches the voltage and phase on the nameplate of the motor. They must match!
2. Verify the 24VAC transformer has the proper connection to the incoming power (the black wire is always connected); White – 115VAC*, Red = 208VAC, Orange = 230VAC, Blue = 480VAC.
3. Verify the primary tap wires match line voltage connected to operator. Measure the line voltage carefully to distinguish between 208V and 230V branch circuits or between 390V and 460V branch circuits. A label on top of the transformer identifies the various voltage taps. This connection must match the voltage on the operator nameplate.

NOTE: Primary taps do not exist on battery operators.

4. Verify the 24VAC is present at the Red and Green wires from the control transformer to the Power Supply Board by measuring the bottom of the power supply board at the -ACC+ connectors.
5. Verify that the main power wires are at least the minimum wire size specified in *Wire Sizing and Runs* on page 17. Be certain that the branch circuit wire size versus the distance of the run from the main panel is large enough to avoid excess voltage drop.
6. Verify 24VDC power is present on the Power Supply Board between the +24VDC terminals above the terminal strip and any screw connection on the terminal strip.
7. Be sure a 20A circuit (protected with a 20A inverse time breaker) is provided.
8. Check and make sure the operator is electrically grounded per NEC Article 250 and local codes.
9. Verify the 24VDC is present at the +24VDC and common terminals located along the lower edge of the Smart Touch Controller board. (RADIO OPTIONS, etc.)
10. Verify that the "Heart Beat" LED is blinking green.
11. Verify the display is operational on the LCD and VFD display.
12. With the knowledge that the power is correct and the electric motor runs, check the STC display. If an error, alert or fault code appears, refer to *Table 8: Troubleshooting Codes* on page 86 to determine possible resolutions.

MECHANICAL ISSUES

Gates that run smoothly and operate well significantly improve the life of the gate operator's motor and component parts. Refer to *Mechanical Maintenance* on page 99.

On site gate movement issues can usually be resolved in the short term by manually moving the gate open and close. See *Releasing the Gate: Manual Operation* on page 10.

HYDRAULIC ISSUES

The speed at which the operator moves the gate is determined by the size of the hydraulic pump and software settings.



Attempting to slow gate speed by changing a valve setting will cause inefficiency and increased heating of the hydraulic system, which will degrade system performance and also may result in premature system failure.

NOTE: If the gate speed must be changed, contact your HySecurity distributor or HySecurity Tech Support.

Extremely cold weather is unlikely to seriously affect the gate speed because HySecurity employs a special grade of hydraulic fluid (Uniflow), which maintains a linear viscosity over a broad temperature range. This high quality fluid, combined with other design considerations, allows HySecurity to rate its operators for service in ambient temperatures of -40°F to 158°F (-40°C to 70°C).

If the gate speed of your operator has been affected by cold weather, perform the following:

1. Verify the gate hardware is not impaired by ice.
2. Verify that the reservoir is filled with Uniflow fluid.

NOTE: Consider adding a heater in extreme cold weather regions. A biodegradable fluid option does exist, but it does not have the same fluid viscosity at extremely low temperatures. The biodegradable fluid option has a temperature rating between -10°F and 158°F (-23°C and 70°C).

TYPICAL PROBLEMS AND TROUBLESHOOTING PROCEDURES

A few typical problems and their associated troubleshooting procedures are provided to facilitate identification and resolution.

PROBLEM 1: Pressing the Open and Close buttons produce no response (nothing happens).

1. Verify the line voltage is present and matches the operator's input voltage requirement + 10%.
2. Verify the control voltage is present at the Power Supply Common and 24VDC terminals. It may be necessary to reset the circuit breaker (black button) on the transformer.
3. If an external Stop button is not used, verify a jumper wire connects Common to Stop.
4. Verify there are no Faults or Errors being reported on the LCD display.
5. Jump COM to the OPEN or CLOSE INPUT and verify that the LED lights on the STC board which indicates that the input is active and working properly. To help in diagnosing the problem, take note of what other inputs light up and check the display for codes.

PROBLEM 2: Hydraulic pump is running and the hydraulic pressure is between 0 - 700 PSI, but the gate is not moving.

The Smart Touch Controller reports system malfunctions on its LCD display and the buzzer will emit a series of chirps at defined intervals. Review the table of Alerts, Faults and Errors listed in *System Diagnostic Messages* on page 85.

To check the status of all inputs on the terminal strip, the LED tact button must be pushed.

If the power is three-phase, verify counter-clockwise Electric Motor rotation. To reverse rotational direction, switch any two AC lines.

NOTE: The VFD Motor Controller displays trip and fault codes. Check to see if any error codes appear on the VFD display. Most VFD issues are resolved through the STC software and modbus interface.

1. Check the hydraulic fluid level by removing the plug in the pump reservoir. If necessary, add fluid at this location until the level is about ½ inch below the filler hole.
2. Unplug the hydraulic hoses and run the pump; if the pressure is low, adjust the Pressure Relief Valve.
3. If the Pressure Gauge does not respond to adjustment of the Pressure Relief Valve, completely remove the valve and depress the plunger at the nose end with a blunt tool (e.g., an Allen wrench) and blow on it to remove any debris.

PROBLEM 3: Hydraulic pressure is above 700 PSI

1. Verify that the quick connects at the hose ends are fully seated on the valve stems.
2. Check the flow control valve, it must not be turned too far clockwise. See *Typical Problems and Troubleshooting Procedures* Instructions on page 94.

PROBLEM 4: The gate only opens or only closes.

1. Verify that no external device is commanding the gate to open or close by watching the LEDs associated with each input.
2. If the gate only opens, the directional valve is probably stuck and needs to be checked for debris and cleared.
3. If the gate only closes, the solenoid coil may not be energizing or it may be defective.
4. Carefully, replace the valve.

PROBLEM 5: The gate panels move in the wrong direction.

1. Check hose connections to verify the correct order red to red and brass to brass. Note that newer gate operators manufactured after 2012, may not have color bands on the quick disconnects.
2. With the system engaged to open, verify that the open valve coil develops a strong pull. (This can be tested by removing the nut retaining the coil and grasping the coil to feel its magnetism.)

PROBLEM 6: A run command causes PEC to appear on display.

1. Check that the photo eye is not blocked. If it is, remove the blockage and realign the photo eye. Refer to Photo Eye Alignment on page 56.
2. If you have a battery-powered photo eye, check that the batteries are viable and fresh.
3. If needed, realign the photo eye.

PROBLEM 6: I have a bi-parting gate system or twin models and the gate panels won't synchronize.

1. Air trapped in the hydraulic system can cause slow or jerky movement and prevent the panels from synchronizing.
1. On twin models, make sure leaf delay (LC or LO) in the Installer Menu is not set.
2. Refer to General Maintenance and read the instructions for bleeding air from the SwingRiser hose which is found in the Hydraulic section.

PROBLEM 7: The gate panels move very slowly and seem to shudder throughout gate travel.

1. Air trapped in the hydraulic system can cause slow or jerky movement..
2. Refer to General Maintenance and read the instructions for bleeding air from the SwingRiser hose which is found in the Hydraulic section.

PROBLEM 8: Gate speed

The speed in which a hydraulic operator moves a gate is determined by the size of the pump and the size of the actuator components. Just like a gear box, this speed is not adjustable. Attempting to slow a gate by changing any valve setting will cause a great deal of inefficiency and heat. If the speed of a gate must be changed, contact your HySecurity distributor.

PROBLEM 9: Gate speed in extremely cold weather

Extremely cold weather is unlikely to seriously affect the speed of the gate, because HySecurity employs a special grade of hydraulic oil which maintains a very linear viscosity over a broad range of temperatures. Because of this high quality oil and other design considerations, we rate our operators for service in ambient temperatures of - 40°F to 158°F (- 40°C to 70°C). If the speed of your operator has been affected by cold weather, verify that the gate hardware is not impaired by ice and verify that the reservoir it is filled with UNIFLOW oil. In severe conditions, consider adding a heater. SwingRiser heaters are available from your distributor.

Page intentionally left blank

General Maintenance

SMART TOUCH ANALYZE AND RETRIEVE TOOL (S.T.A.R.T.)

HySecurity provides Smart Touch Analyze and Retrieve Tool (S.T.A.R.T.) software to help HySecurity gate operator users and installers conduct the following field service activities:

- Configure installer and user menu settings
- View the operator history (event) log
- Display monitored inputs for operator diagnostics
- Load Smart Touch Controller (STC) software



With S.T.A.R.T. software loaded on your laptop computer, you have an invaluable management tool for all HySecurity operators. The RS-232 serial port (found on the Smart Touch Controller), allows you to download system diagnostics and upload system configurations using the S.T.A.R.T. software. Instructions for downloading S.T.A.R.T. are on the website.

What You Need

HySecurity Serial RS-232 communication cable with USB adapter and current USB driver.

- Laptop computer with Windows PC operating system (XP, Vista, Win7, Win8, or Win 10)
- Minimum 128MB of RAM
- Minimum 5MB of hard drive disk space
- VGA graphics card (minimum resolution of 800 x 600)

Installing S.T.A.R.T. Software

Read the [S.T.A.R.T. User Manual](#), and then take the following steps to download S.T.A.R.T. software:



The latest version of S.T.A.R.T. is encrypted. An error message will appear stating that the file is corrupt if you try to load new operator code using out-dated S.T.A.R.T. software. Be sure to “uninstall” any outdated versions of S.T.A.R.T. from your laptop and install the latest version.

1. Bring up your web browser and type <https://www.hysecurity.com> in the command line.
2. Click Technical Support (left column) on the HySecurity home page.
3. Click Download: Smart Touch software.
4. Enter your user name and password. If you do not have a user name, register as an online member.
5. Click S.T.A.R.T. Software for Smart Touch and SmartDC to being the software download.
6. Read the End User License Agreement and, if you agree to the terms, click, “**I accept**” (bottom of page).

7. Save the START< >_setup.exe file to your desktop.
8. Double-click the file to begin the installation.
9. Click RUN. A setup window appears.
10. Follow the step-by-step instructions to complete the installation.*
11. When the download is complete, log off the HySecurity website. Shortcuts for the S.T.A.R.T. and STC History Logs should appear on your laptop's desktop.*

***NOTE:** Confirm you have administrative rights by clicking the following on your computer screen: Windows start ->Control Panel ->User Accounts ->User Accounts. See if your name appears as an administrator. If you are the only user of a computer, you are by default the administrator. If not, you may need to consult with your company's system administrator prior to downloading the HySecurity S.T.A.R.T. program.

SOFTWARE MAINTENANCE

The software on the STC board is periodically being enhanced with new features that create an easier install and improve the on-board diagnostic tools. Be sure to check the HySecurity website for the latest version of software and operator code before heading out for field maintenance.

ELECTRICAL CONTROLS

NOTICE: Before servicing, turn off all power switches.

No routine maintenance is needed for the electrical system or controls. If the environment is very sandy or dusty, or has many insects, be certain to seal all holes in the electrical enclosure. Blow the dust out of the electric panel with compressed air. Use the *Table 8: Troubleshooting Codes* on page 86 to assess and fix error, alert, and fault codes. If it is necessary to call a distributor for assistance, be sure to have your model and serial number ready. Other helpful information includes the name of the job, approximate date of installation, and the service record of the operator, especially if any work has been done recently.

Clock Battery Replacement

A lithium coin battery supports the clock, so the date and time is retained even when the main power is turned off. Replace the battery about every five years (or as needed) with a DL 2025, DL 2032, or CR 2025, or CR 2032 battery.

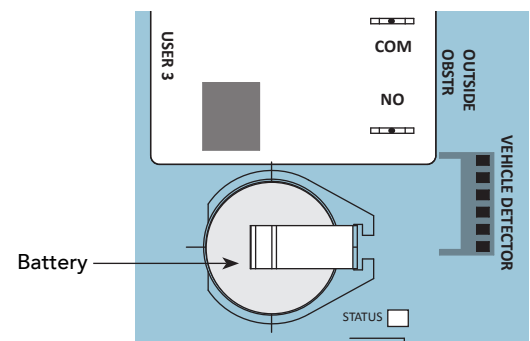

MECHANICAL MAINTENANCE

NOTICE: Before checking the internal mechanisms of the operator, turn off all power switches.

The mechanical maintenance for the HySecurity gate operator is not in depth or difficult, but should be performed on a routine basis.

Schedule regular maintenance:

- ❑ Check for signs of rust. The operator chassis is zinc plated which is corrosion-resistant, but some environments may increase the rate of corrosion. If any areas of rust are found, reduce the spread of corrosion by treating the areas with a rust inhibitor.
- ❑ Grease hydraulic cylinders using NLGI #2 Grade Moly EP lithium base grease only and apply it with a standard grease gun. Grease other bearing locations per *SwingRiser Operator Maintenance Schedule* on page 108.
- ❑ Replace worn-out batteries.
- ❑ Maintain gate hardware in good-working order.

Operator Post

The operator post is the workhorse of the gate. Schedule regular maintenance on the operator post to include the following:

Smooth gate operation: Open and close the gate several times. Check for consistent speed and smooth stops. If adjustment is necessary, refer to Adjustment of the Flow Control Regulating Valve.

Indexing arm: To hold the gate in the correct position, the indexing arm may need to be adjusted to align the locking pin with its receptacle. Adjustment is usually required only after the gate has been hit by a vehicle or otherwise damaged.

To adjust, refer to Mounting the Gate Panel, Index Arm, and Locking Pin Assembly.

The most reliable operation occurs when the indexing arm is adjusted to over-extend the gate closure. The goal is to have the locking pin strike its receptacle firmly. The added pressure in the slight over-extension of the gate aids in keeping the locking pin aligned in its receptacle.

UHMW bearings and shims: Inspect the white UHMW plastic bearings (inside the upper and lower portions of the square post). See the photo in the Cut-away View. The bearings are designed to wear during normal operation and must be inspected at regular intervals and re-shimmed or replaced, as necessary.

- If the gap between the bearing and the inner tube exceeds 1/8-inch (3mm), the bearing needs to be re-shimmed. See *Reshimming the Bearings*.
- If the bearing is extensively worn and 1/4-inch (6mm) or less of plastic bearing material remains, replace the bearing. Replace both the upper and lower bearings by following the steps in *Replacing the Bearings*.

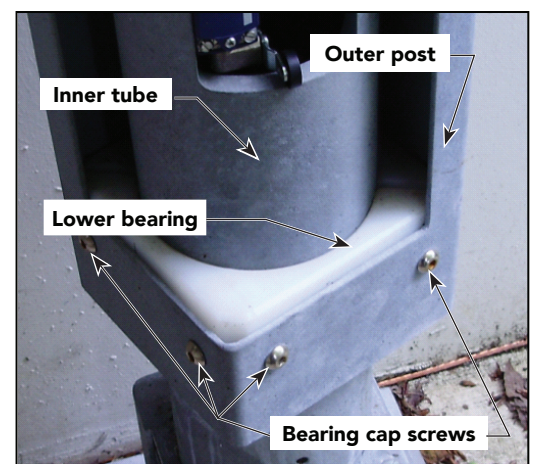

Cut-away view of SwingRiser post

NOTE: If you plan to replace the bearings, a replacement part kit must be ordered from HySecurity. The kit includes the upper and lower UHMW bearings and 16 shims.

Reshimming the Bearings

To add shims, you need to order the Shim Kit. It includes four 0.020 and four 0.060 shims. Refer to the HySecurity Price Book for the appropriate part number.

Important aspects to consider when you are shimming bearings:

- One half of the bearing is usually worn more than the other. Use different shim thicknesses (0.020 or 0.060) to keep the inner tube centered inside the post.
- The weld seam inside the post may prevent the shim from sliding behind the bearing cleanly. If this happens, cut 1 inch out of the middle of a shim and install the two slotted pieces on each side of the weld.

To install shims, take the following steps:

1. To access the upper bearing, close the gate.
2. Turn off the gate operator's power source. This ensures that the gate will not move while you are installing the shims.

IMPORTANT: Measure the thickness of the material remaining in the upper bearing. Be sure to measure the thinnest portion of the bearing. If the thickness is $\frac{1}{4}$ -inch or less, do not use the shims. Instead, replace both the upper and lower bearings. See *Replacing the Bearings*.

3. Use a jack screw to lift and block the gate panel. This transfers the weight off the bearings.
4. Loosen, but do NOT remove the four screws in the outer post that secure the worn portion of the bearing. There are four $\frac{1}{4}$ -20 tapped holes adjacent to the screws. Bolts ($\frac{1}{4}$ - 20) may be screwed into these holes to aid in adjusting the gap while shimming.
5. Make a shim packet with 0.060 and 0.020 shims and close the gap tolerance to under 0.020 of an inch. Use a feeler gauge to measure the gap.

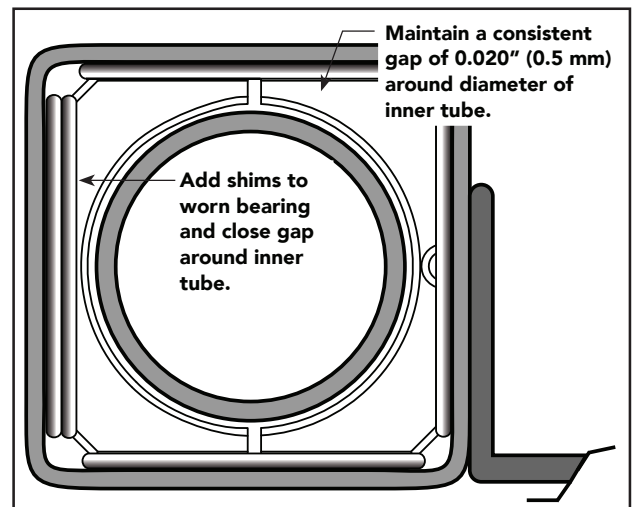
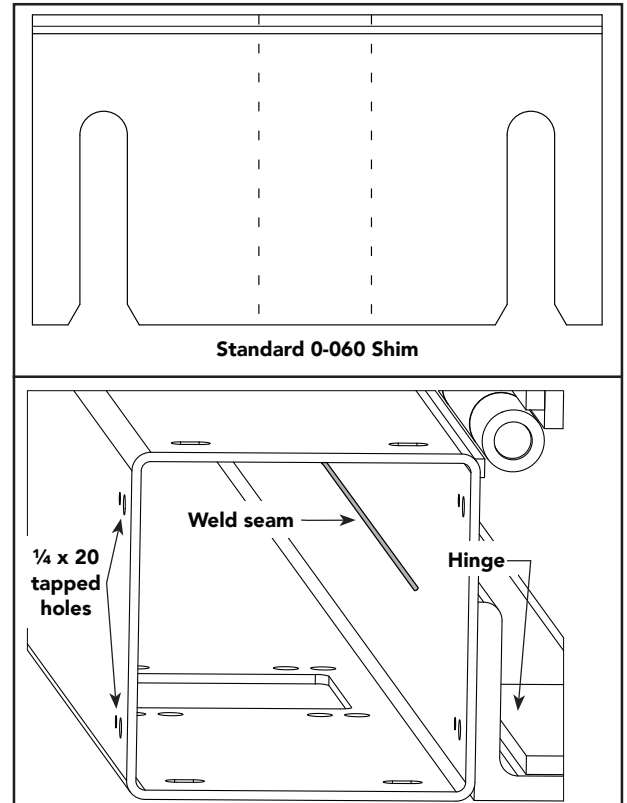

- Force the shim pack into the space between the worn bearing (A) and the square post. If the gap between the inner tube and the bearings (both portions A and B) remains higher than 0.020-inches, loosen the screws that secure portion B and force equal-sized shim packets between bearing (B) and the outer post.

IMPORTANT: Keep the bearings centered and maintain a consistent gap around the diameter of the $\frac{3}{4}$ " (19 mm) inner tube. Another way to measure for consistent gap tolerance is shown in the illustration. If the distance between the outside of the post and the outside diameter of the tube equals $\frac{3}{4}$ " (19mm) and the bearings are centered, a consistent gap should exist around the inner tube. It is likely that the gap is within the needed 0.020 tolerance.

- Re-tighten the screws to secure the re-shimmed bearings.
- Remove the block from the gate.
- Turn the power back on.

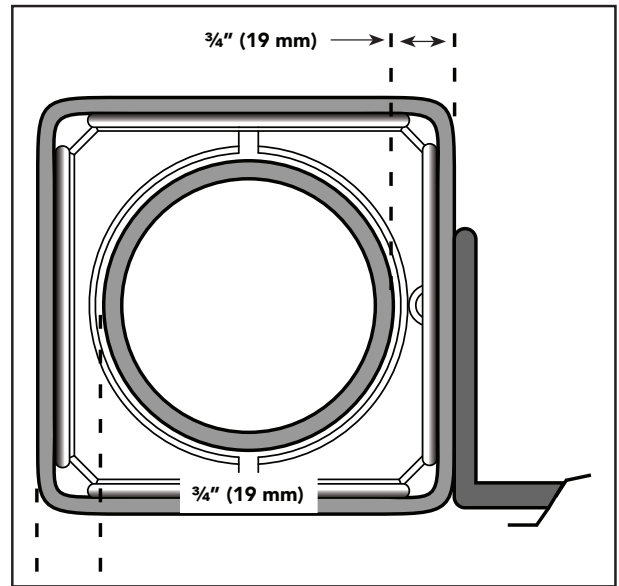

Replacing the Bearings

To replace the bearings, you need to order the replacement part kit. You may want to order replacement fasteners as well. You will need eight cap screws per bearing.

Part #	Name	Description
MX001718	SwingRiser Bearing and Shim Kit, Upper & Lower	Includes upper and lower post bearings and 16 shims. This kit can be used on operators manufactured from 2/2008 to the present.
MX001089	Nickel-plated cap screws (3/8 x 16 x 1-inch)	Replacement fasteners. If needed, order eight cap screws per bearing.

NOTE: If you are working on a SwingRiser manufactured prior to January 2008, refer to the Technical Bulletin: SwingRiser Maintenance – Bearing Replacement and Shimming.

Important aspects to consider when you are replacing bearings:

- Locate the weld seam inside the square post. It should run along the side that is attached to the gate hinges. The notched portion of the bearing half must be installed so that the notch aligns with the weld seam. If the weld seam is not evident inside the post, place the bearing so the notch is on the hinge side.
- Shims are inserted at the factory with 0.0 to 0.020-inch clearance in relation to the post. Replacement bearings need to be shimmed to a similar clearance.
- When installing new bearings, use an equal number of shim packets on opposite sides. The packets may be composed of 0.060 and 0.020 shims.
- Always start with a .060" shim on each of the four outside edges when installing a new rectangular bearing.

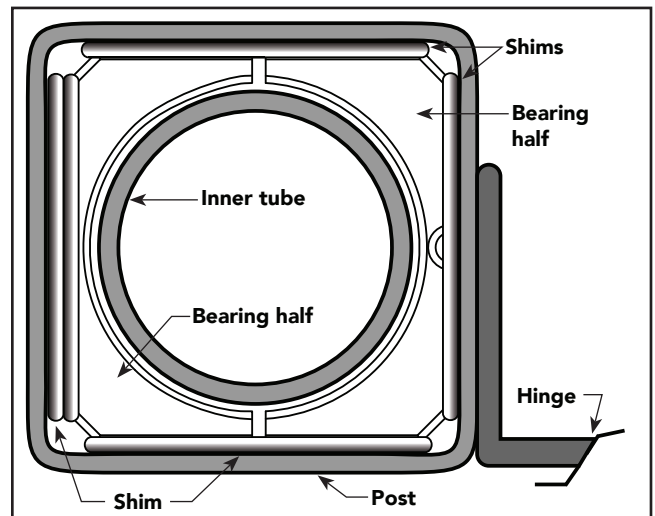
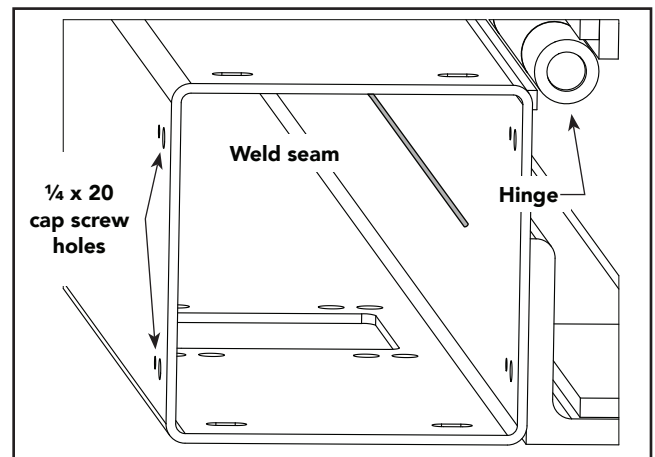

To replace the bearings, take the following steps:

NOTE: Refer to SwingRiser Bearings Chart to determine what replacement kit you need to order.

1. To access the upper bearing, close the gate.
2. Turn off the gate operator's power source. This ensures that the gate will not move while you are installing the bearings.
3. Use a jack screw to lift and block the gate panel. This transfers the weight off the bearings.
4. Loosen the post screws and remove any shims surrounding the bearings.
5. Alleviate the possibility of the bearing falling into the post's interior by using two self-tapping screws and some string. Fasten a separate strand to each screw. Turn the screw into each half of the UHMV plastic bearing until each screw is secure.
6. Remove the four screws in the outer post that hold the worn half of the bearing in place. Pull on the string to remove the bearing from inside the post, and then perform the same step for the other half of the bearing.
7. Use the screw and string technique on the two new bearing halves. Make sure the notch in the bearing is aligned with the post's weld seam.
8. Replace both bearing halves and use the fasteners removed in step 6 to hold them in place. Do not fully tighten the fasteners until the shims have been properly installed.
9. Shim each side evenly so the distance between the outside edge of the post and the inner tube is equal to $\frac{3}{4}$ -inch (19mm). Make sure the bearing halves are centered in the post and the gap surrounding the inner tube is consistent.
10. Remove the block from the gate.
11. Turn the power back on.
12. Open the gate to access the lower bearing.
13. Repeat steps 2 through 11 to replace the lower bearing.

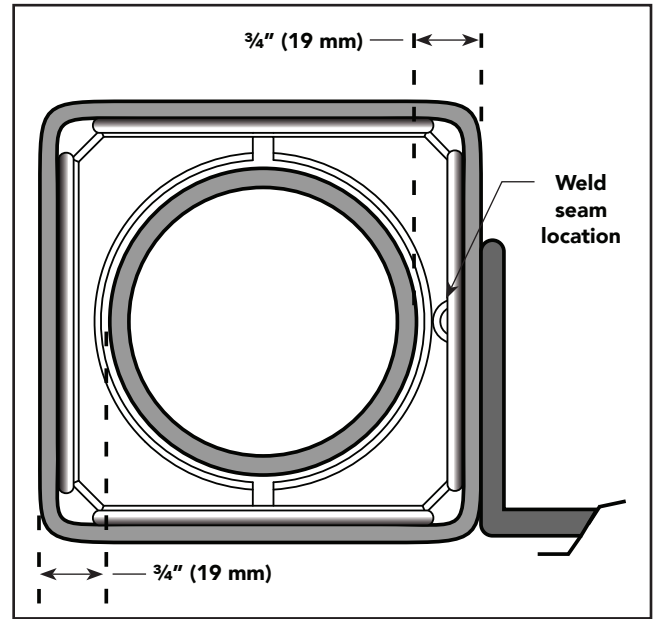

SwingRiser Index Arm Assembly

Two spacers (5/8-inch nuts) have been added to the SwingRiser index arm assembly. The stabilizing index arm directly affects the cam and its path inside the support post. When the index arm is held securely in its mounting bracket, the outcome increases the longevity of SwingRiser components.

For assembly instruction, review the illustration below and the drawings in the *SwingRiser: Index Arm & Locking Pin OverView on page 126*.

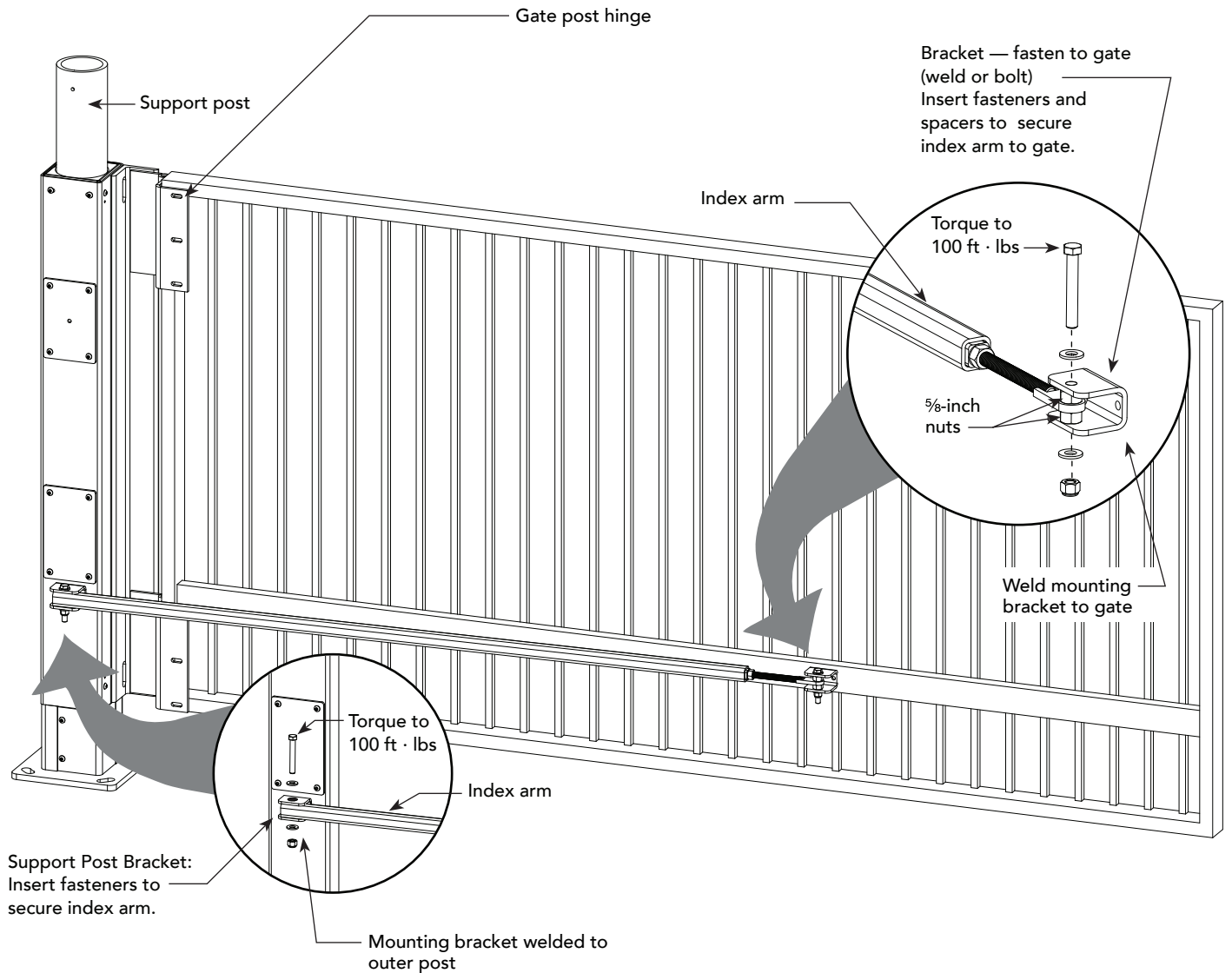

HYDRAULIC SYSTEM MAINTENANCE

Fluid Level: Under normal conditions, hydraulic systems do not consume fluid. Check the system thoroughly for leaks, before adding any fluid. If fluid needs to be added:

1. Remove the metal plug from the tank.
2. Use HySecurity Uniflow hydraulic fluid; part number MX000970. Gallon sold by our distributors.
3. Fill to within ½ inch of the plug level, and then replace plug.

NOTICE: Never use brake fluid. It will severely damage the hydraulic system. Use of any fluid other than fluid recommended by HySecurity may void the operator warranty.

Look for leaks: Occasionally there may be slight seeping at the fittings after some usage. Tightening of the fittings usually corrects the problem. If leaking persists, replace "O" rings, fittings or hoses, if required. No further leaks should occur.

To Change Fluid: Unlike a gas engine, the fluid inside a hydraulic system does not foul, so fluid changes do not need to occur often. HySecurity recommends draining the reservoir and replacing the fluid at five-year intervals. Fluid breakdown caused by heat is the main concern. If the unit is subjected to high use, or you are using the HySecurity biodegradable fluid option (especially in a warm climate), change the fluid more frequently.

To change the hydraulic fluid,

1. Remove the reservoir from the pump pack.
2. Completely empty it.
3. Wipe the reservoir clean and clean the debris screen.
4. Re-assemble the pump unit and refill it with new Uniflow hydraulic fluid.
5. To avoid overfilling, slowly pour the fluid through the filler port near the reservoir's top until the fluid is within one inch of the port's opening.
6. Replace the plug and wipe up any spilled fluid. Spilled fluid dries to a sticky and messy consistency.

Cold Weather Issues:

1. Check that your reservoir is filled with our Uniflow high performance fluid.

Excessive ice buildup can partially or totally jam gate operation. Operate the gate manually, while clearing the ice buildup.

If the operator is located in an area of extreme snow conditions, regular maintenance to dig the operator out may be required. A heater option may help.

NOTE: A biodegradable fluid option does exist, but it does not have the same fluid viscosity at extremely low temperatures. Uniflow fluid temperature rating is between -40°F and 158°F (-40°C and 70°C). The biodegradable fluid has a temperature rating between -10°F and 158°F (-23°C and 70°C).

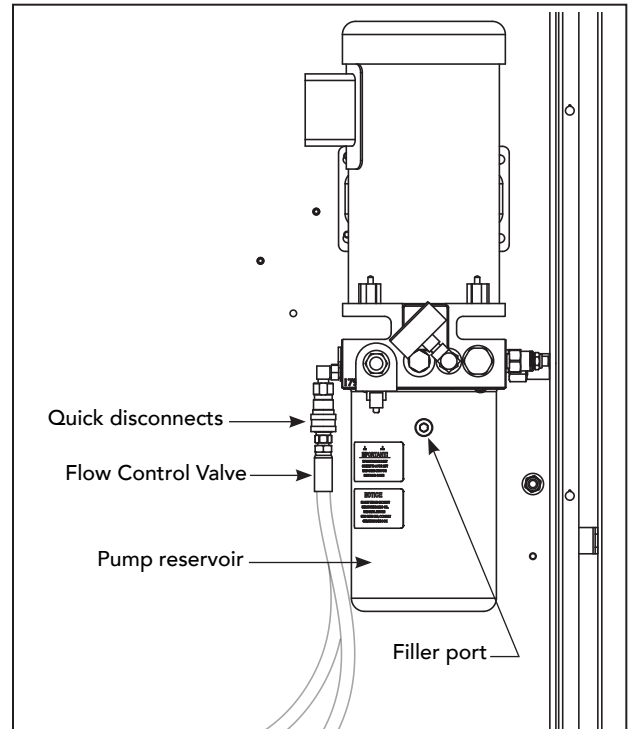

Adjusting the Pressure Relief Valve

The Pressure Relief Valve governs the maximum system hydraulic pressure. It is located on the backside of the pump. The pressure relief valve is factory set and may need to be adjusted depending on the gate weight.

Pressure relief valve adjustments establish the threshold for the inherent entrapment sensor (IES). The optimal pressure setting produces uniform gate travel and trips the IES when the gate encounters an obstruction.

See *Pressure Relief Valve – All Hydraulic Operators*: on page 25 and follow the instructions.

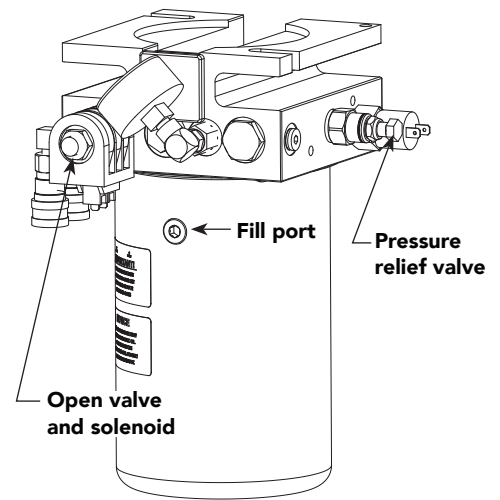

Open Valve

The open valve is solenoid operated and, when energized, directs the hydraulic flow to open the gate. No adjustment of this valve is possible or necessary. The black solenoid coil mounts on its valve stem.

Adjustment of the Flow Control ValveA Flow Control Valve with color bands is used on older operators. A flow control valve without color bands is now used in the production of SwingRiser operators.

If you have a flow control valve without color bands, use the following steps to restrict hydraulic fluid flow back to the pump pack. This action can fine tune the closing speed of the gate.

NOTE: To affect closing speed adjustments on a broader scale, change the pump pack size and the motor's horsepower.

Adjusting the Flow Control Valve



Before adjusting the flow control valve, the SwingRiser posts must be installed, plumb, and wired to the HydraSupply. The gate must be secured on the posts with its index arm attached, adjusted, and tightened. Note that over-tightening the flow control valve causes the gate operator to draw more motor horsepower than necessary or desirable. Over time this aspect can cause additional stress and wear on the hydraulic power unit and void the warranty.

Use the flow control valve to fine-tune the gate's closing speed. As the gate slows (optional locking pin rests into its locking receptacle), use the fine-tuning of the flow control valve to make proper adjustments. The valve affects how quickly the hydraulic fluid flows to the pump pack, effectively changing the closing speed of the gate.

NOTE: The flow control valve is for fine-tuning the closure speed on the gate. To affect closing speed adjustments on a broader scale, change the pump pack's size and the motor's horsepower.

Two different methods exist for flow control adjustments. Older SwingRiser operators have color bands, newer operators do not. Make sure you are following the correct steps.

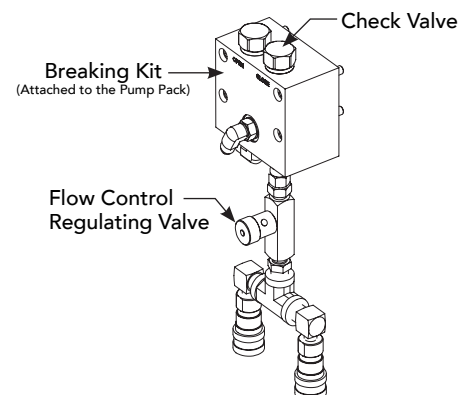

Adjustment of the Flow Control Valve without Color Bands

If you have a flow control valve with color bands, DO NOT use the following steps. Take the steps in *Adjustment of the Flow Control Valve with Color Bands*.

1. Start with the operator in the closed position. When the gate is closed, GATE CLOSED appears on the display.
2. Using a 5/64-inch hex key, loosen the small set screw located on the flow control regulating valve.
3. Press the OPEN button on the keypad. Let the operator run until it stops on the open limit.
4. Press CLOSE. As the gate moves in the closed direction, slowly turn the flow control regulating valve in one of the following directions to adjust the closing speed:
 - Clockwise – restricts the hydraulic fluid flow back to tank, increases pressure and, to a small extent, slows the closing speed
 - Counterclockwise – increases the hydraulic fluid flow back to tank, reduces pressure and boosts closing speed
5. Make adjustments so the gate closes smoothly and does not over-swing or slam into or against the lock socket.
6. Run a few open and close cycles to make sure the flow control adjustment is set properly.

NOTE: Check the pressure gauge as the gate closes and opens. Make sure the steady state pressure is slightly higher as the gate closes than when it opens. The flow control regulating valve is only to be used for fine adjustments. The valve affects the hydraulic fluid flow to the pump pack tank which, in turn, slightly affects the closing speed of the gate. To make larger scale adjustments to gate closing speed, you need to change the size of the pump pack and the motor.

7. With the gate stopped in the closed position, tighten the small set screw that was loosened in step 2.
8. Follow the bleeder tool instructions to bleed air out of the hydraulic lines.

Adjustment of the Flow Control Valve with Color Bands

SwingRiser gate operators employ the use of a flow control valve to allow slight adjustments in the closing speed of the gate.

To adjust the close flow control valve correctly, take the following steps:

1. Pre-set the valve set such that only two of the color bands (red & blue) below the adjusting knob are exposed.
2. Run the gate in the close direction and turn the flow control valve clockwise until you have achieved a proper gate closing speed and the locking pin sets gently into position.
3. Other important adjustments are necessary for correct locking. See *SwingRiser Index Arm Assembly on page 104*.
4. Be sure to tighten the set screw on the adjusting knob to lock your adjustment

BLEEDING AIR FROM SWINGRISER HOSES

Air trapped in the hydraulic systems of SwingRiser (HRG) operators can cause slow and/or jerky operation. In SwingRiser Twin (HRG 222) systems (two gate panels operating from a single hydraulic supply), air can prevent the two panels from synchronizing.

If these symptoms are appearing in your operator, you may need to bleed the air from the hoses between the hydraulic supply and the operator post.

In SwingRiser Twin systems, both posts must be bled at the same time. The gate will be inoperative during the bleeding process. If traffic needs to pass, remove the index arm and pivot the gate on the mounting hinges manually.

Tools required:

- 7/32" Allen wrench (for cover plate screws)
- Bleeder tool assembly, refer to the HySecurity Price Book for the part number.
A single gate requires one Bleeder tool. A twin gate system requires two Bleeder tools.
- Two electrical jumper cables

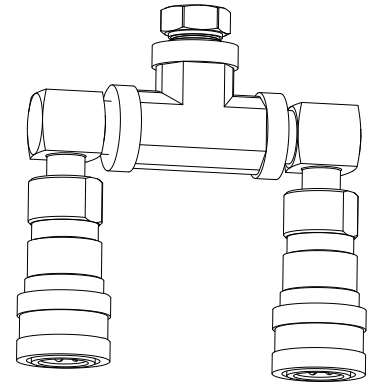

Bleeder Tool

Detailed instructions on how to use the bleeder tool are shipped with it. You can also find the instructions online by logging into your distributor or installer site and accessing [Technical Support Resources](#), [Replacement Part Instructions](#).

SWINGRISER OPERATOR MAINTENANCE SCHEDULE

Name of part	What to do	Check at these recommended monthly intervals				
		1	3	6	12	24
Gate and hardware	Check for damage and wear *1	X				
Anchor bolts	Check for tightness *2			X		
Large Hydraulic cylinder	Grease end pin (50,000 cycles) *3				X	
Hydraulic cylinder (inside)	Grease end pin (100,000 cycles) *4				X	
Fluid level	Check for loss fluid *5				X	
Hydraulic fluid	Drain and replace fluid *6					X
Clock battery	Replace *7					X

Special Notes:

- *1. Your gate and gate hardware will require more maintenance than your HySecurity operator. A damaged gate or worn hardware may cause slow or erratic operation and will result in excess drive wheel wear. Lubricate gate hardware more frequently and check for smooth operation by opening the toggle clamping mechanism and then pushing the gate manually. One person should easily be able to push all but the largest of gates. Damaged or warped gate panels should be straightened or replaced.
- *2. Check the anchor bolts are tight and the cover secure.
- *3. Grease the large hydraulic cylinder end pin as regular maintenance every 50,000 cycles or 1 year (whichever comes first).
- *4. Grease the two serk fittings on the hydraulic cylinder trunion bearing (inside, near base of the cylinder) regularly, every 100,000 cycles or 1 year (whichever comes first).
- *5. The fluid level should remain no less than one inch below the filler hole. Refer to maintenance instructions for fluid filling. Loss of fluid is not normal and indicates a leak that must be located and repaired. Use Uniflow fluid, part MX000970, if additional fluid is required.
- *6. Every two years, drain the hydraulic fluid and refill the reservoir. Use Uniflow fluid only, part MX000970.
- *7. Replace the Smart Touch Controller battery with DL 2025 / DL 2032 or CR 2025 / CR 2032.

Wiring HySecurity Sensors: Smart Touch

Wiring diagrams are provided on the following pages. The diagrams illustrate how to connect sensors and program the gate operator. HySecurity Smart Touch gate operators can monitor entrapment protection sensors per UL 325 - 2015 Standard of Safety using software version h4.50 (or later).

The site designer or installer must determine which external entrapment protection sensors will be installed with the gate operator to create a UL 325 compliant installation site. For additional information, review [Gate Safety on the HySecurity website](#).

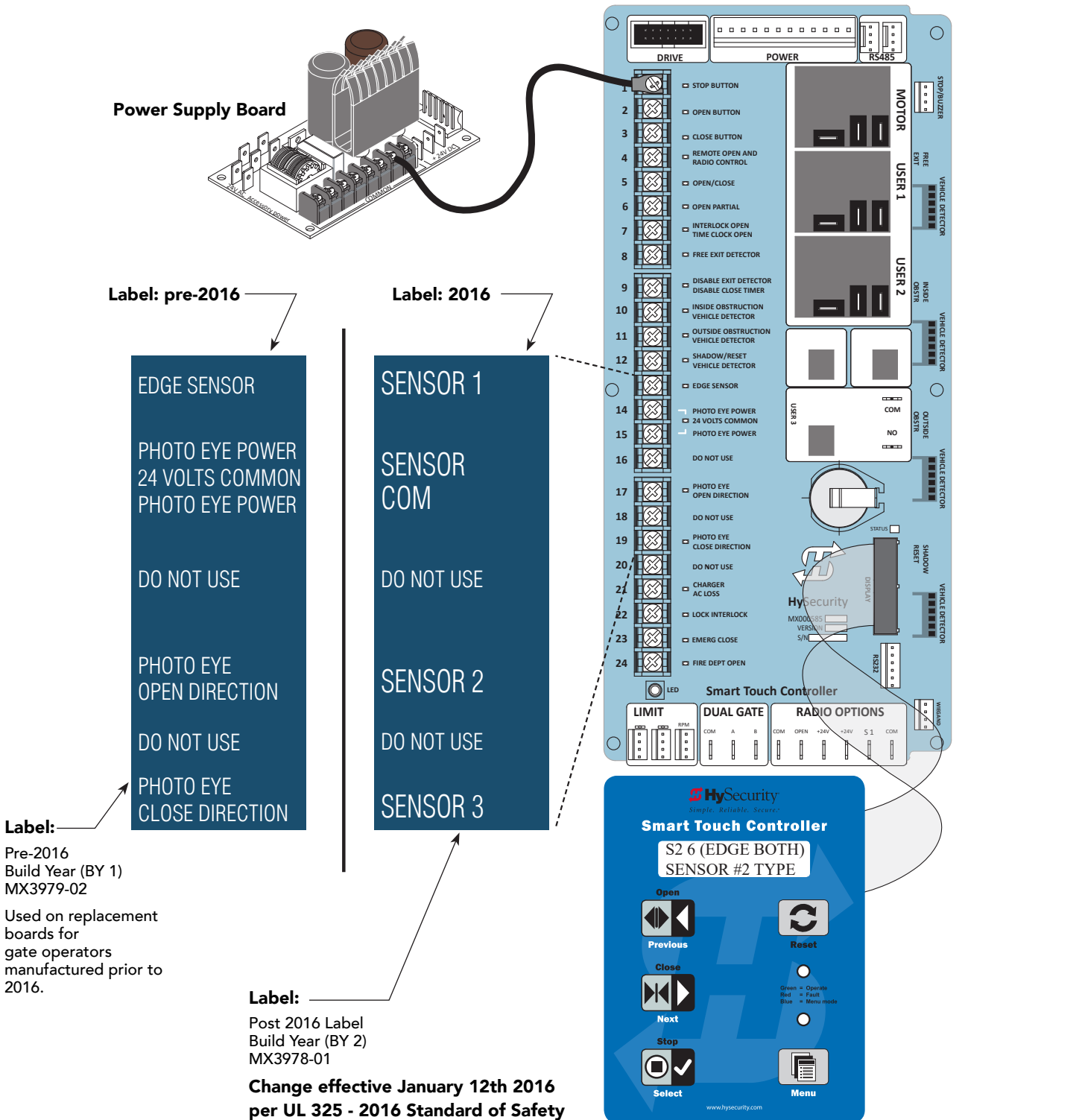

WIRING TIPS FOR SENSOR COM TERMINAL: SMART TOUCH

Two SENSOR COM terminals exist (Terminal 14 and Terminal 15). If using multiple sensor devices, use a wire nut as a junction and pigtail to SENSOR COM. Or, install a separate terminal block and jumper outputs to one lead for either SENSOR COM terminal.



All external entrapment protection sensors must be NC sensor outputs and wired to the SENSOR COM terminal for monitoring and powering purposes. The sensor becomes actively powered when the gate operator receives a run command.

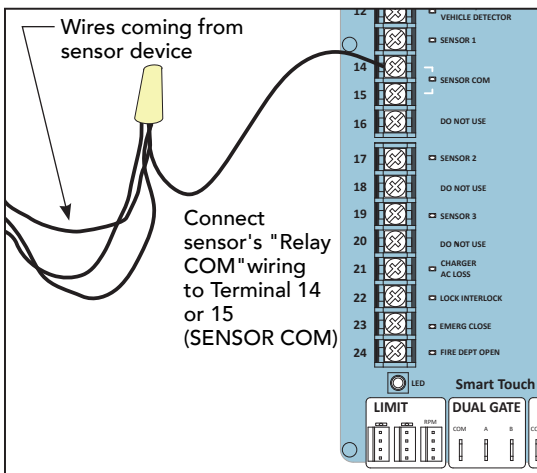

Wire nut and pigtail to SENSOR COM

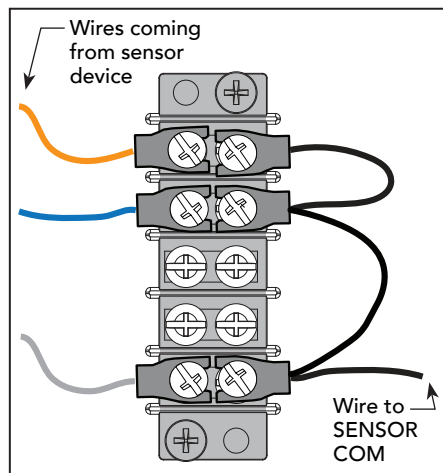

Add terminal block

NOTE: LEDs next to the sensor connections will be lit when NO POWER is being applied. To temporarily supply power to the sensors. See *Photo Eye Alignment Feature* on page 82. When PE is turned ON, the LEDs turn off. If they do not turn off, check for wiring issues such as a short or misapplied relay COM connections. See *Supply Power to the Sensors* on page 30.

MENU MODE NAVIGATIONAL TIPS

Press the Menu buttons to access Menu mode. The gate will not run while in Menu mode. The buttons on the display keypad perform certain functions while in Menu Mode. Refer to the chart.

To change data appearing in the display	To navigate through the Selections	To choose what appears on the display	To navigate between menu items
Press Select . Two left characters blink.	Press Next or Previous . Continue pressing Next to view all selections.	Press Select . Blinking characters become static.	Press Next or Previous . Advance - press Next Previous - press Previous

SMART TOUCH: WIRED EDGE SENSOR WITH GEM (-104)

1. Turn OFF power.
2. Connect the Green NC relay wire from GEM-10 to Sensor 1, 2, or 3.
3. Connect Red & Green wires from GEM-104 to SENSOR COM on Controller (or Power Supply Board, STC).
4. Connect Red wire from GEM-104 to +24V on Controller (or Power Supply Board, STC).
5. Connect Black & White wire from GEM to 10K resistor in edge sensor.
6. Turn ON power and access the Installer Menu. Configure SENSOR setting accordingly (i.e. Edge Open, Edge Close, or Edge Both). See *Table 4: Installer Menu Settings for SENSOR Inputs* on page 29.

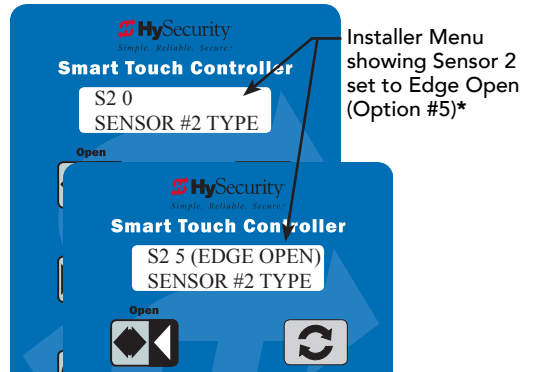

All external entrapment protection sensors must be NC sensor outputs and wired to the SENSOR COM terminal for monitoring and powering purposes. The sensor becomes actively powered when the gate operator's motor runs.

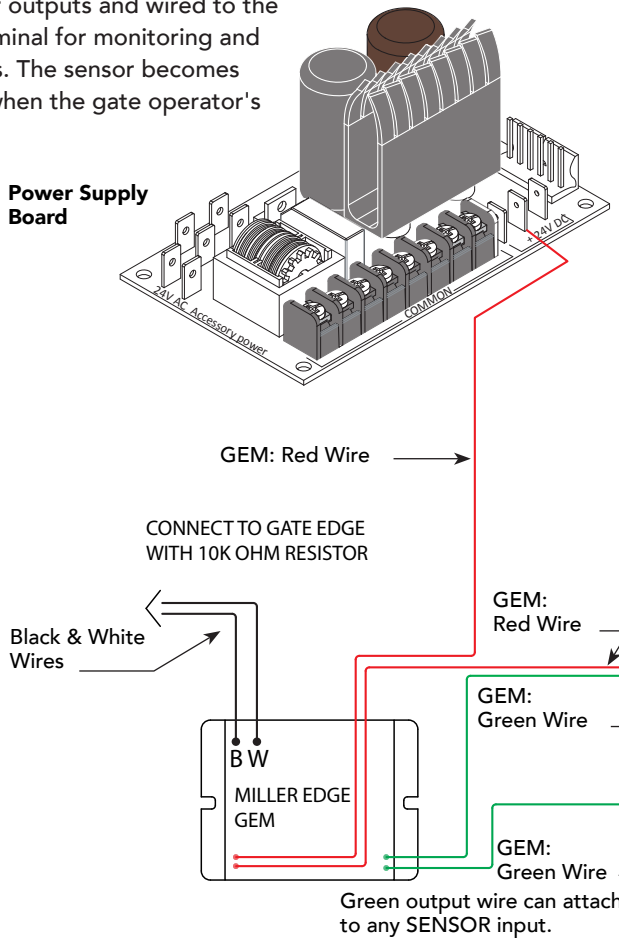

***NOTE:** Make sure whichever wired input used (SENSOR 1, 2, or 3) is the same Sensor # configured through the Installer Menu.

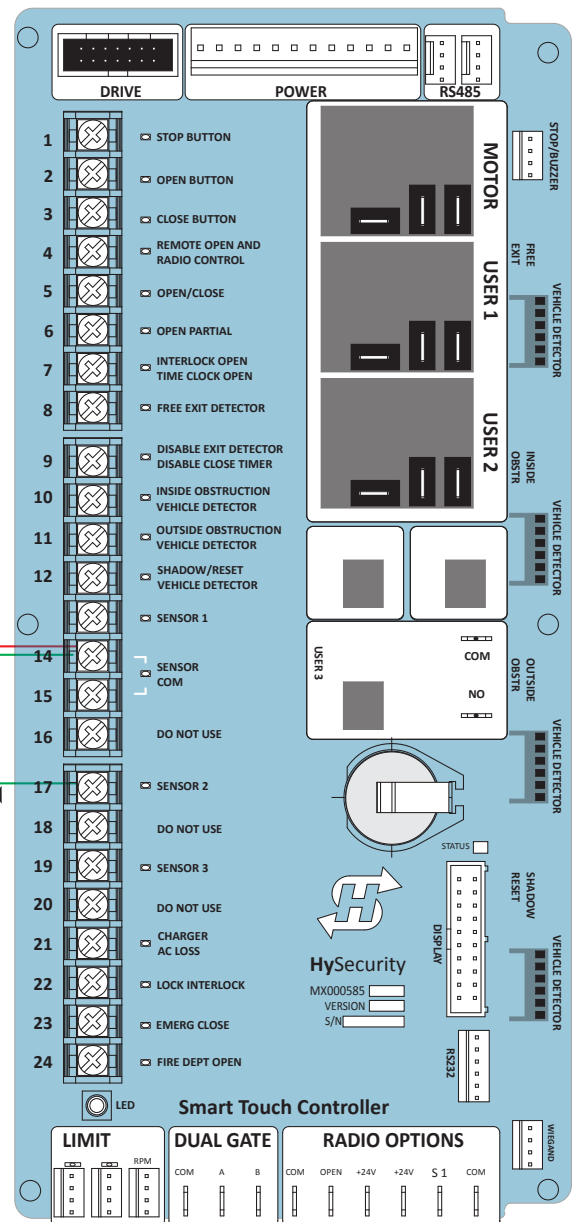

SMART TOUCH: PHOTO EYE THRU BEAM (EMX IRB MON)

1. Connect photo eye wiring.
NOTE: Run a jumper between photo eye -24V (POWER INPUT) and COM terminals on the Receiver.
2. Turn ON power.
3. Access the Installer Menu and configure SENSOR setting according to the entrapment area that the photo eye is monitoring. Refer to table on page 29.

***NOTE:** Make sure whichever wired input used (SENSOR 1, 2, or 3) is the same Sensor # configured through the Installer Menu.

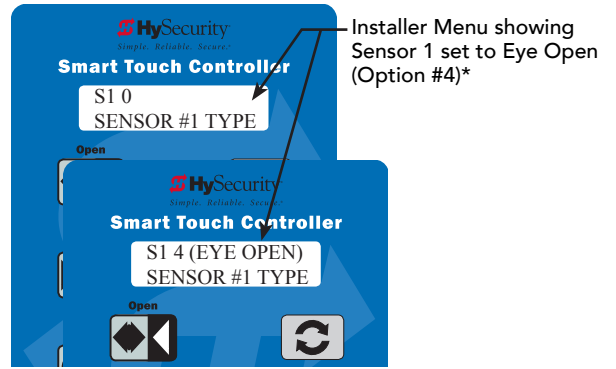

EMX IRB MON Photo Eye Transmitter

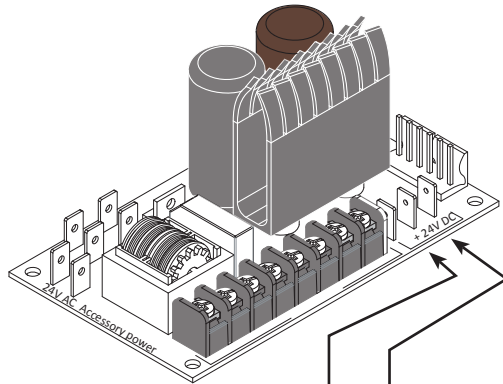
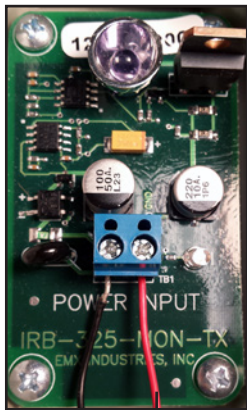

Power Supply Board



EMX IRB MON Photo Eye Receiver

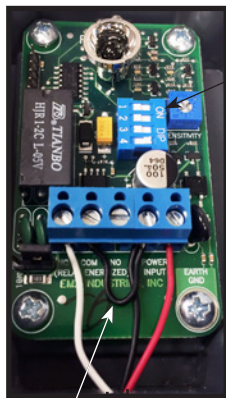

CAUTION

- Set DIP Switches
- 1 = OFF
 - 2 = OFF
 - 3 = OFF
 - 4 = ON

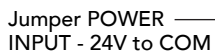

COMMON / NEG. to SENSOR COM

NC Relay

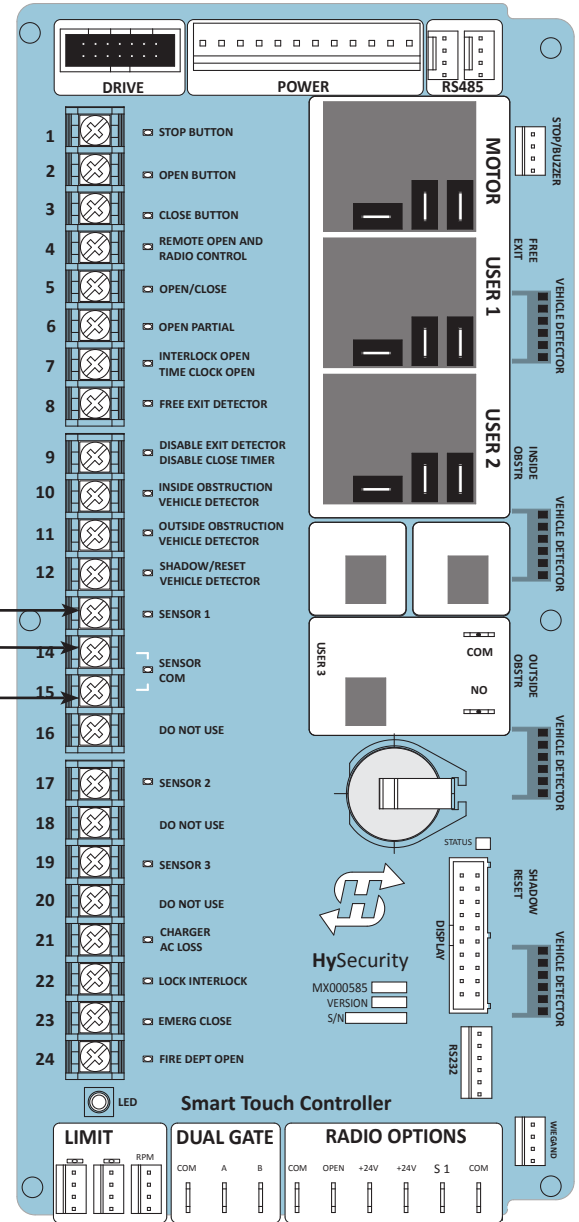

CAUTION

DIP switches must be set as shown otherwise the photo eye will not operate correctly. If you receive an Alert, "!ACTION BLOCKED" "Photo Eye Open" PEO or "Photo Eye Close" PEC, take steps to align the photo eye. Refer to *Photo Eye Alignment Feature* on page 82.

SMART TOUCH: PHOTO EYE / REFLECTIVE (E3K R10K4)

1. Set Photo Eye switch to LIGHT ON. See NOTE.
1. Connect photo eye wiring.
NOTE: Run a jumper between photo eye -24V and Relay COM (C2) terminals. See photo.
2. Turn ON power.
3. Access the Installer Menu and configure SENSOR setting according to the entrapment area that the photo eye is monitoring. Refer to table on page 29.

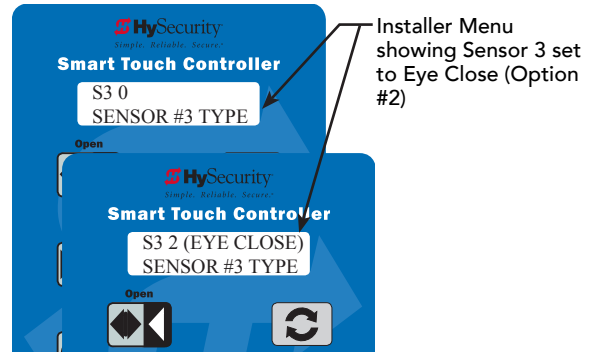

All external entrapment protection sensors must be NC sensor outputs and wired to the SENSOR COM terminal for monitoring and powering purposes. The sensor becomes actively powered when the gate operator's motor runs.

Power Supply Board

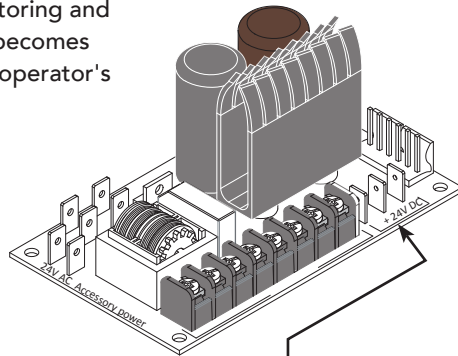

Omron (E3K R10K4) Reflective Photo Eye

NOTE: Light/Dark switch must be set to LIGHT ON.



Do NOT connect the 10K resistor to HySecurity gate operators. Follow the instructions on this sheet to avoid FAULT 2.

+24V

Jumper -24V to Relay COM (Terminal 6, C2)

Relay NO (Terminal 5, NO2)

COMMON / NEG. to SENSOR COM

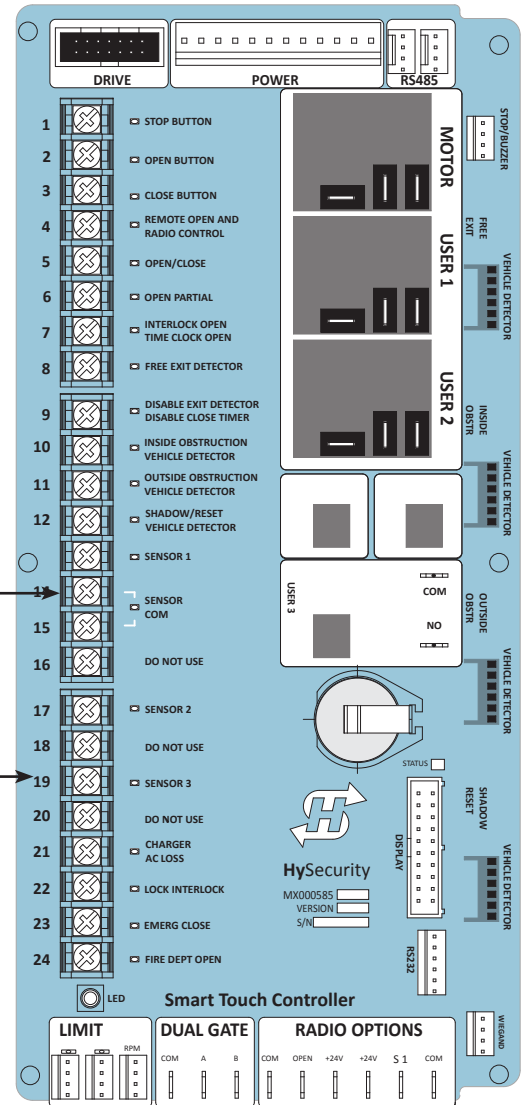

NOTE: If you receive an Alert, "!ACTION BLOCKED" "Photo Eye Open" PEO or "Photo Eye Close" PEC, take steps to align the photo eye. Refer to Photo Eye Alignment Feature on page 82.

SMART TOUCH: THE SOLUTION, MIM-62 (MULTI-INPUT MODULE)

1. Turn OFF AC power.
2. Input channels 1 and 2 must be used and are always assigned to OUTPUT A.
3. All other input channels may be configured to either A or B.

NOTE: If different sensor types are connected to the same output, then program the Controller SENSOR type for EDGE options.

4. Turn ON power.
5. Access the Installer Menu. Configure SENSOR setting according to the types of sensors wired to the Smart Touch Controller.

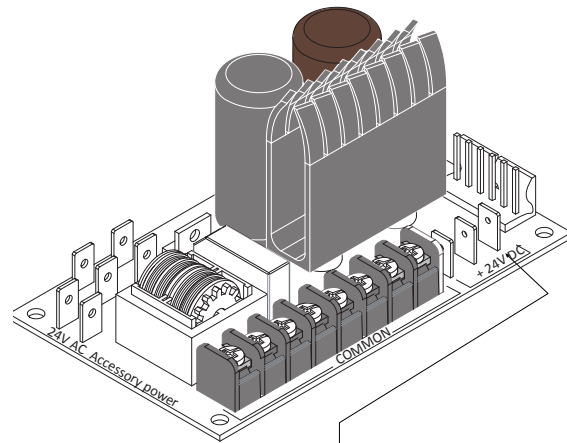

Power Supply Board

Connect either output (P/NC wire) to SENSOR 1, 2, or 3.

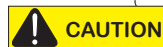
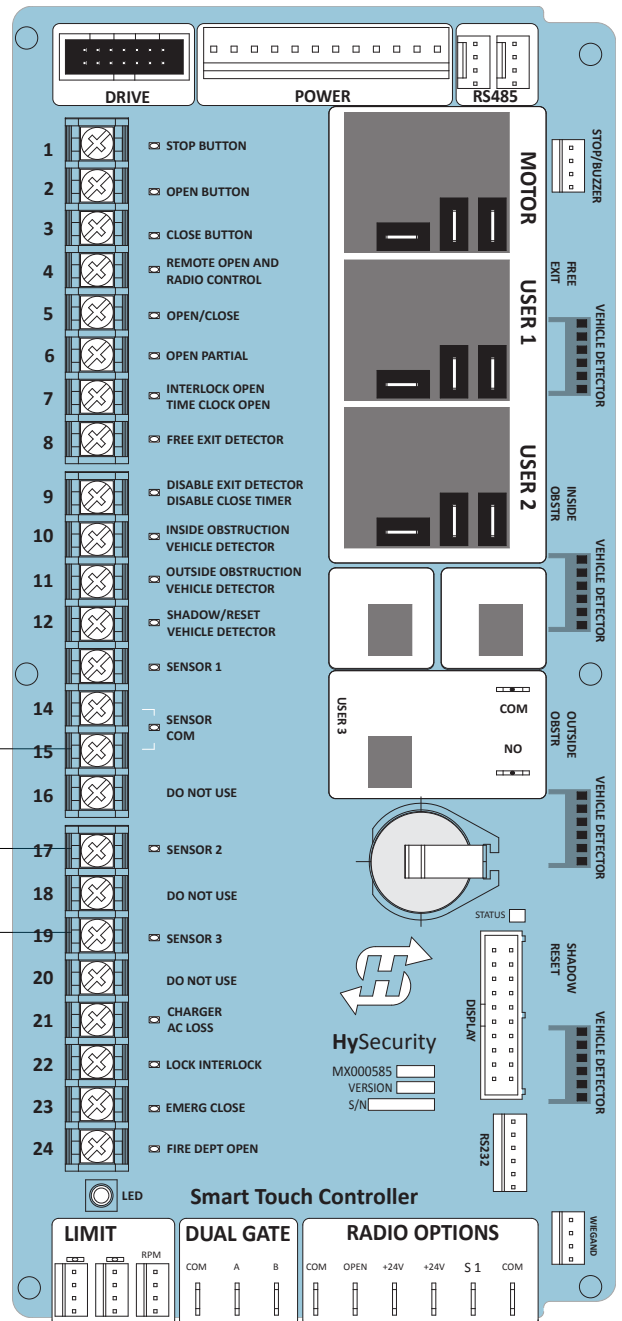
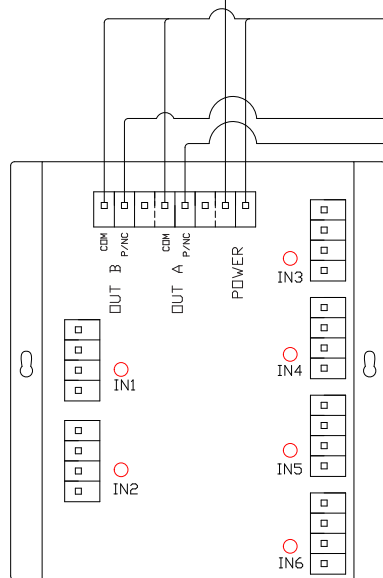

All external entrapment protection sensors must be NC sensor outputs and wired to the SENSOR COM terminal for monitoring and powering purposes. The sensor becomes actively powered when the gate operator's motor runs.

SMART TOUCH: PHOTO EYE / REFLECTI-GUARD (RG-R)

1. Connect photo eye wiring.
NOTE: Run a jumper between photo eye -24V and CM terminals.
2. Turn ON power.
3. Access the Installer Menu and configure SENSOR setting according to the entrapment area that the photo eye is monitoring. Refer to table on page 29.

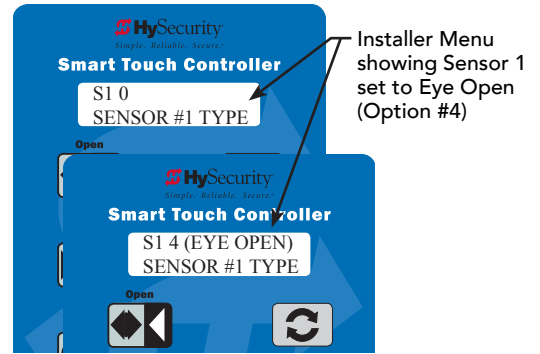

All external entrapment protection sensors must be NC sensor outputs and wired to the SENSOR COM terminal for monitoring and powering purposes. The sensor becomes actively powered when the gate operator's motor runs.

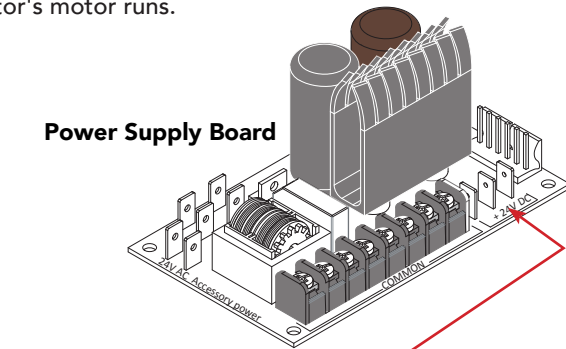

+24V

Reflecti-GUARD Photo Eye

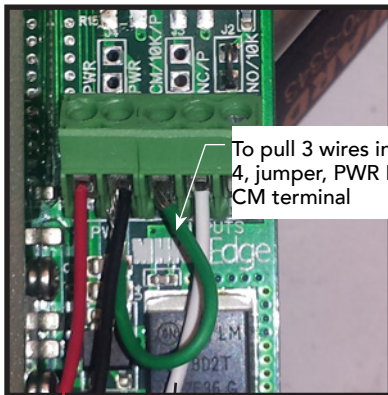

To pull 3 wires instead of 4, jumper, PWR Relay to CM terminal

Connect NC relay wire to SENSOR 1, 2, or 3.

COMMON / NEG. to SENSOR COM

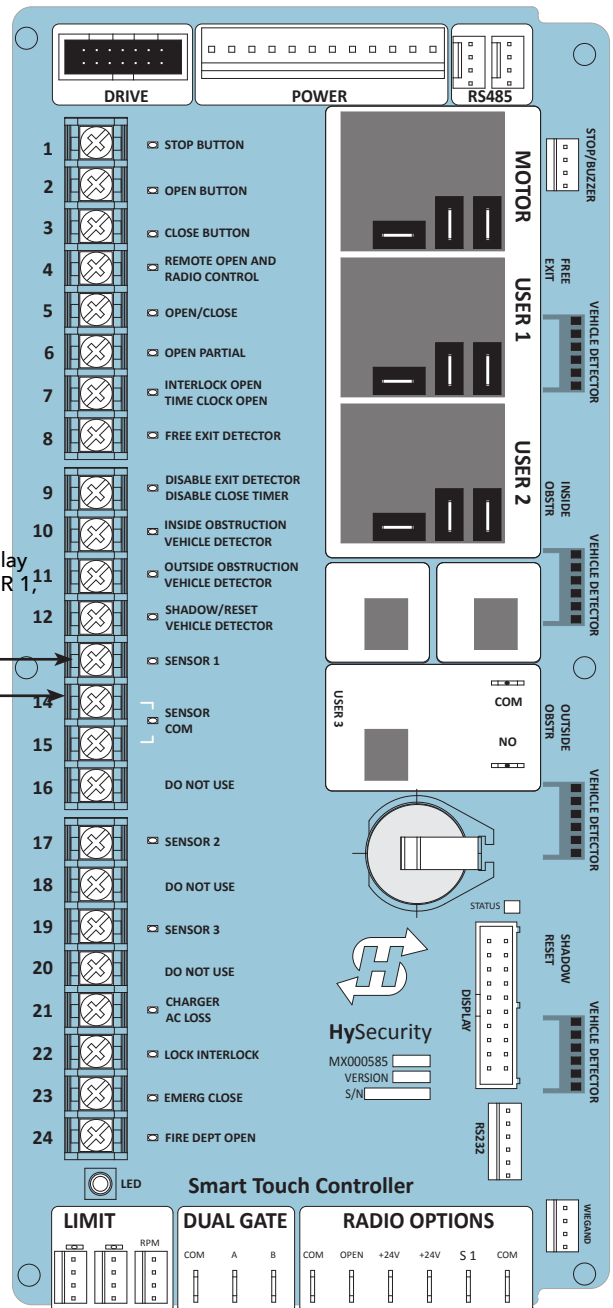

NOTE: If you receive an Alert, "!ACTION BLOCKED" "Photo Eye Open" PEO or "Photo Eye Close" PEC, take steps to align the photo eye. Refer to *Photo Eye Alignment Feature* on page 82.

SMART TOUCH: WIRELESS EDGE, WIRELESS GATE LINK

A transmitter (MGL-TX20) and receiver (MGL-RX20) are required.

1. Turn OFF power.
2. Connect the wiring per the diagram shown.
3. Turn ON power and access the Installer Menu.
4. Configure SENSOR setting accordingly (i.e. Edge Open, Edge Close, or Edge Both). Refer to table on page 29.

Installer Menu showing SENSOR 2 set to EDGE OPEN (Option #5) and SENSOR 3 set to EDGE CLOSE (Option #3)

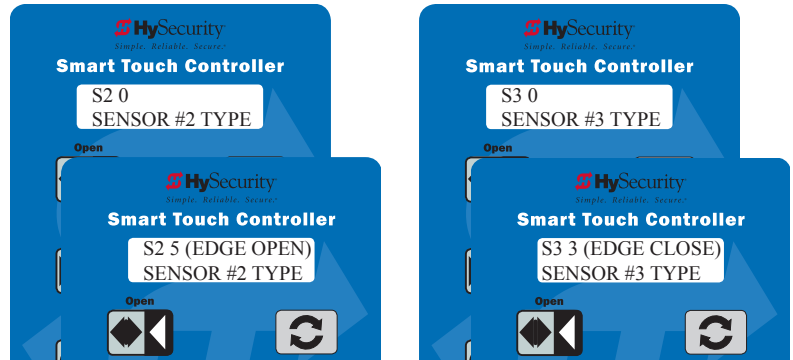

Power Supply Board

All external entrapment protection sensors must be NC sensor outputs and wired to the SENSOR COM terminal for monitoring and powering purposes. The sensor becomes actively powered when the gate operator's motor runs.

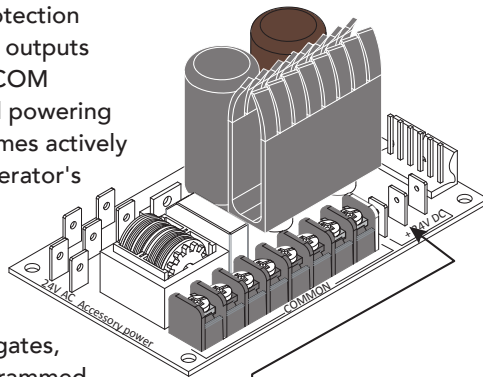

NOTE: In bi-parting swing gates, CH1 and CH2 may be programmed to the same SENSOR # TYPE on one controller, but each CH must be connected to separate SENSOR inputs. Always make sure that a gate edge is installed on each bi-parting swing gate.

Be aware. Issues with radio interference cause false trips. Placing the antenna high and reducing environmental "noise" is critical to proper wireless transmission. Avoid placing the receiver sets within 100 feet of each other as crosstalk may occur.

NOTE: Use Miller Gate Edges that have a wire marked with Blue Tape. The Blue Tape indicates a resistor is built in. Use receivers and transmitters, labeled Version 1.02 or later.

Miller Edge LEARN mode. Press the LEARN button on the Receiver for 2 seconds until the amber light blinks continuously. Press the Edge or Test button on the Transmitter to complete the LEARN mode process and sync the receiver and transmitter.

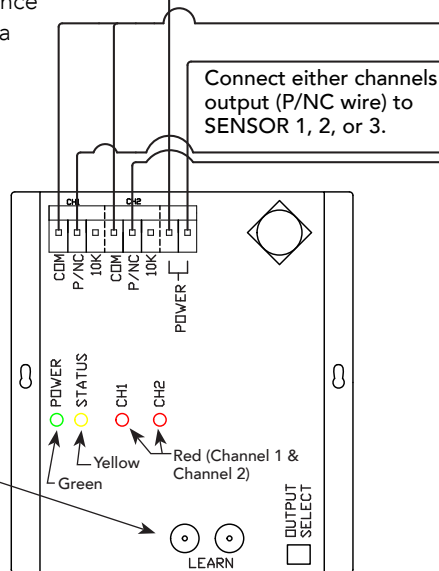

**Wireless Edge Link (Receiver)
MGL - RX20**

Signal received from battery-powered Transmitter (MGL - TX20)

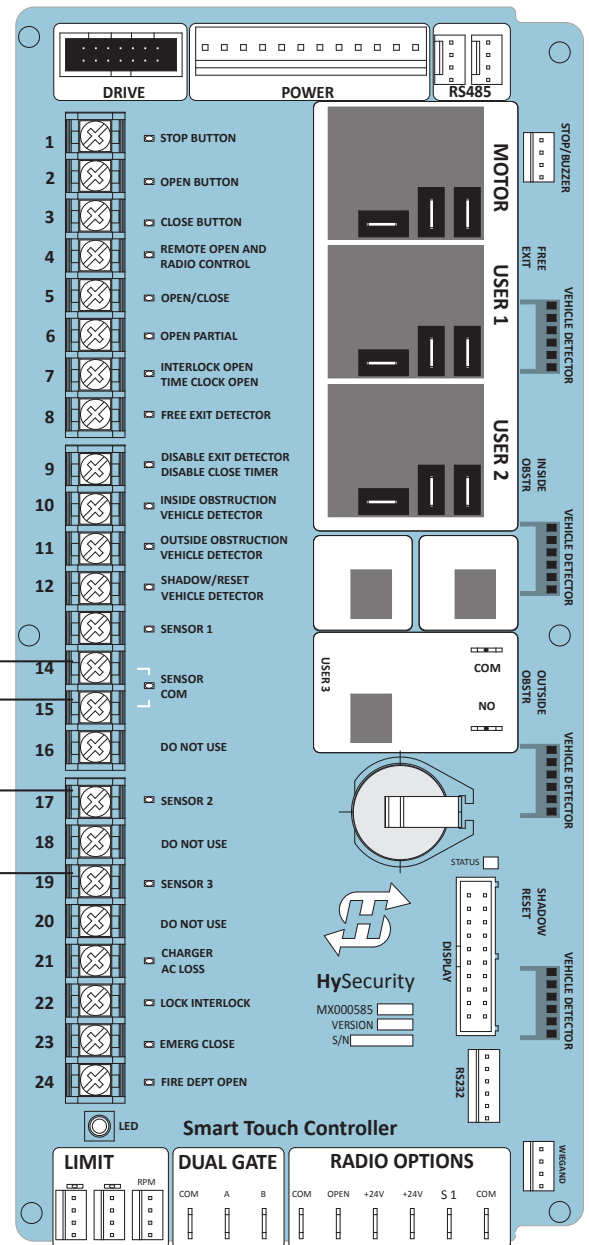

SMART TOUCH: WIRED EDGE WITH GEM-104 & PHOTO EYE

The wiring diagram illustrates a wired edge sensor with GEM-104 interface module and a photo eye connection. Don't forget to set the Installer Menu settings for the Smart Touch Controller (STC). See example on the next page.

See *Photo Eye Alignment Feature* on page 82.

EMX IRB MON Photo Eye Transmitter

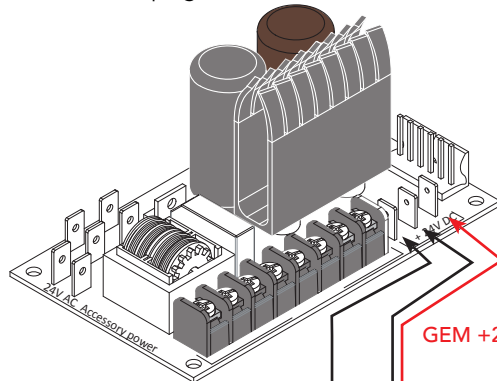

Power Supply Board



Set DIP Switches

- 1 = OFF
- 2 = OFF
- 3 = OFF
- 4 = ON

NOTE: DIP switches must be set as shown otherwise the photo eye will not operate correctly.

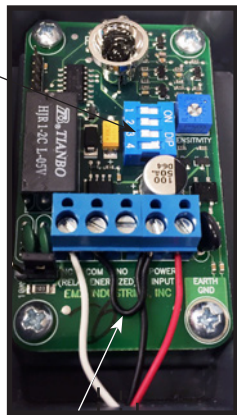

EMX IRB MON Photo Eye Receiver

Jumper POWER INPUT - 24V to COM

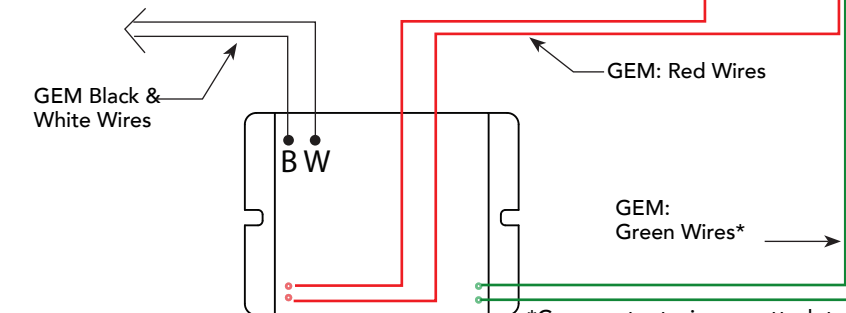

*Green output wire can attach to any SENSOR input.

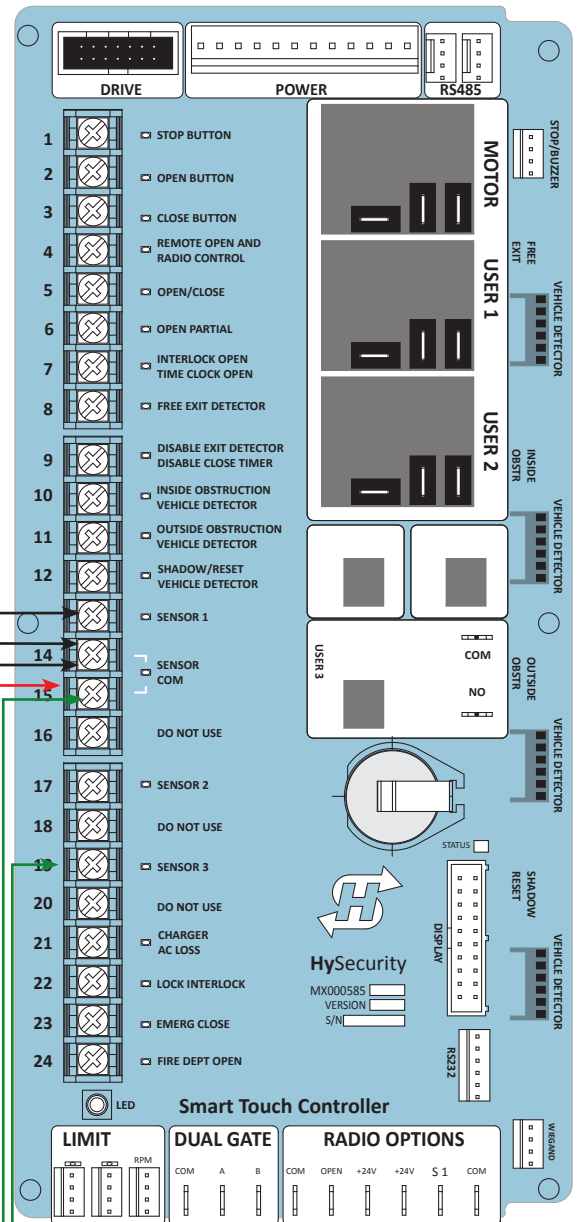

All external entrapment protection sensors must be NC sensor outputs and wired to the SENSOR COM terminal for monitoring and powering purposes. The sensor becomes actively powered when the gate operator's motor runs.

SMART TOUCH: WIRELESS EDGE GATE LINK & PHOTO EYE

The wiring diagram illustrates a wireless edge receiver and a photo eye connection. See *Photo Eye Alignment Feature* on page 82.



Connect all contact and non-contact sensors to same power source. Example, Do NOT connect photo eyes to +24VDC and gate edges to +12VDC. Incompatible electricity flow. A FAULT 2 will appear.

EMX IRB MON Photo Eye Transmitter

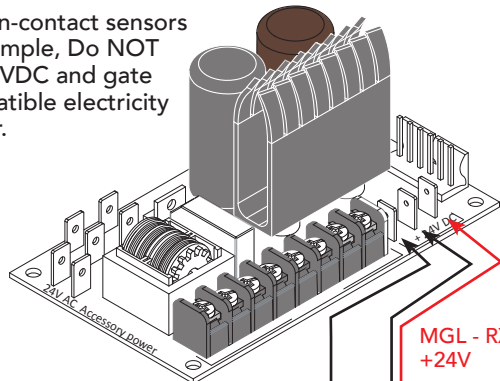

Power Supply Board

Photo Eye Transmitter +24V

COMMON / NEG. to SENSOR COM



Set DIP Switches

- 1 = OFF
- 2 = OFF
- 3 = OFF
- 4 = ON

NOTE: DIP switches must be set as shown otherwise the photo eye will not operate correctly.

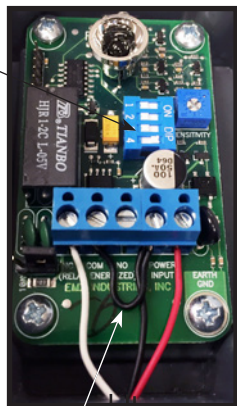

EMX IRB MON Photo Eye Receiver

+24V

Jumper POWER INPUT - 24V to COM in Receiver

Miller Edge 2 Channel Wireless Receiver (MGL - RX20)

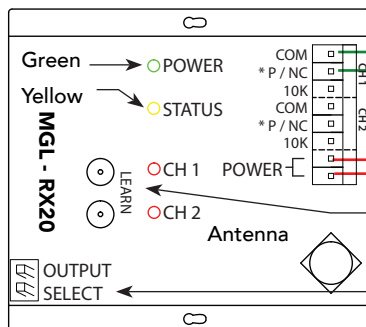

COM attaches to SENSOR COM

*Sensor wire (P/ NC) can attach to any SENSOR input.

CH 1 and CH 2 "LEARN" buttons. To identify and sync to one active transmitter, follow manufacturer's installation instructions. Use receivers & transmitters Version 1.02 or later.

DIP switches for CH1 and CH2. Verify dip switch is set to "R" for each channel used. HySecurity uses NC "Relay" sensors. Do NOT select "P" as the output. P = "Pulse" device.

Configure Installer Menu items: SENSOR 1, 2, & 3

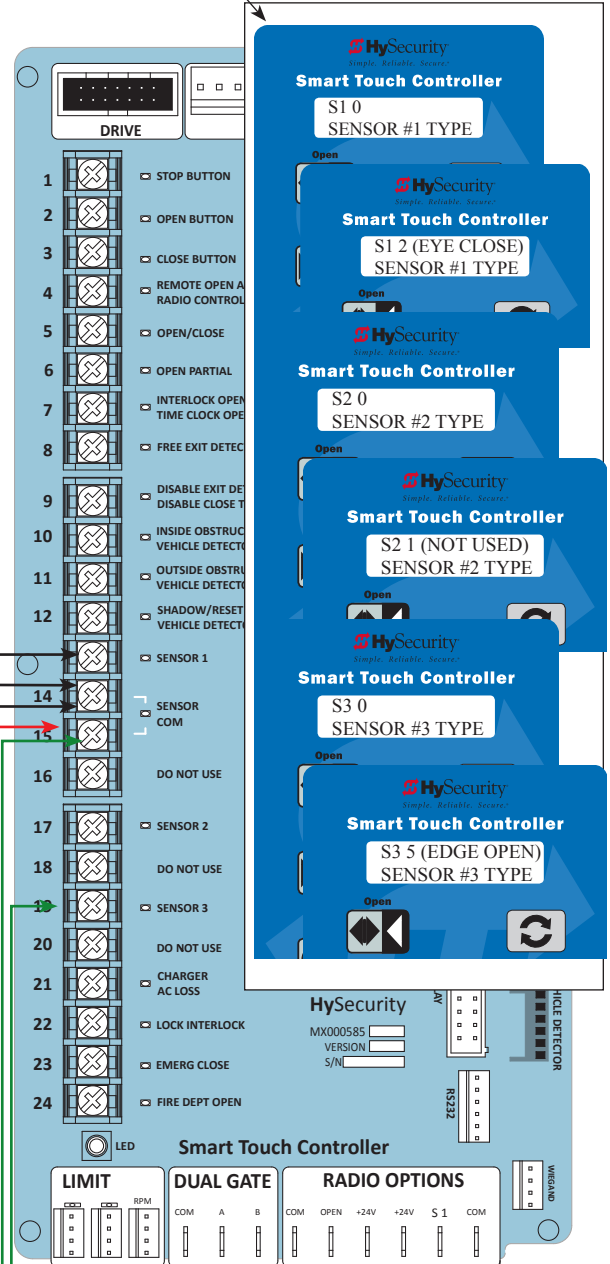

All external entrapment protection sensors must be NC sensor outputs and wired to the SENSOR COM terminal for monitoring and powering purposes. The sensor becomes actively powered when the gate operator's motor runs.

SwingRiser Installation Drawings

Drawings pertinent to SwingRiser installation are found in this section. For additional information and order forms, refer to the [HySecurity website](#). Before installing the SwingRiser, read this manual thoroughly. Site design and installation is the responsibility of the site specifier and installer. The information provided in these pages is for reference only.

SWINGRISER: GATE SWING AND PILLAR / POST VIEWS

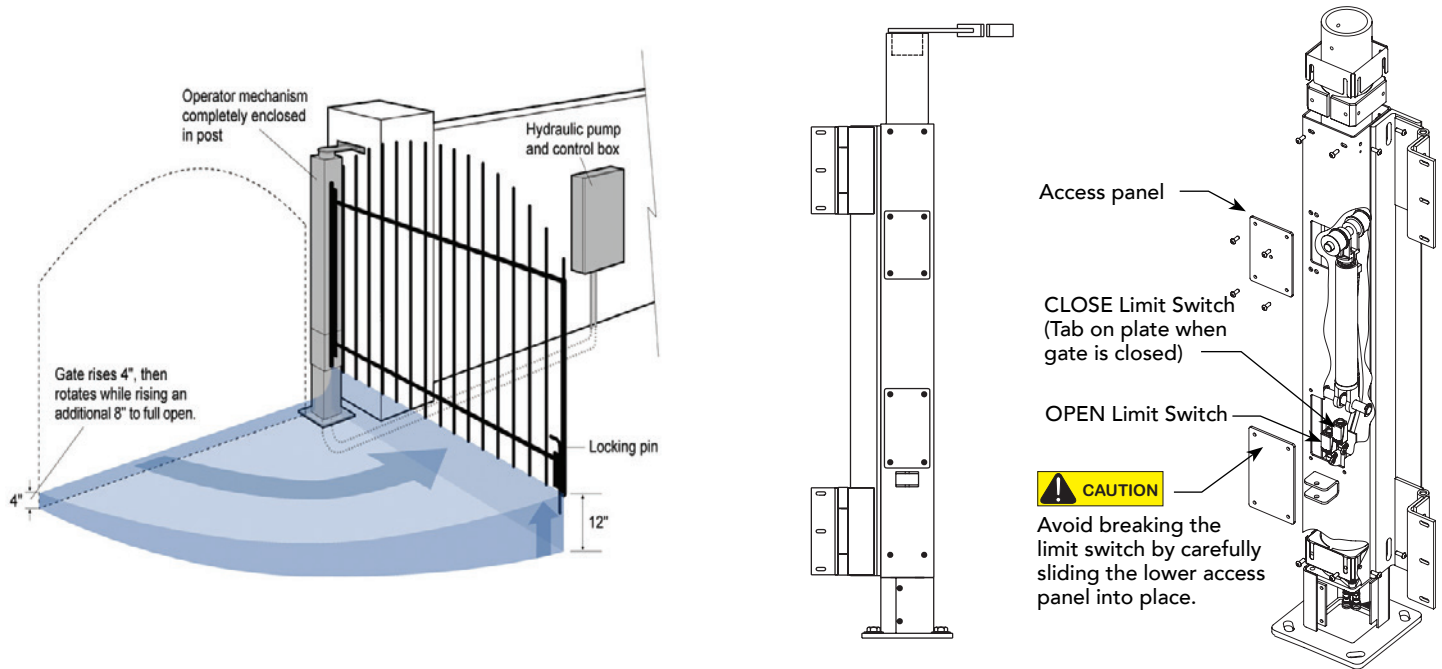

SwingRiser Posts: Double Hinge

SWINGRISER TWIN: SITE SKETCH

See *Site Planning Samples* on page xiv.

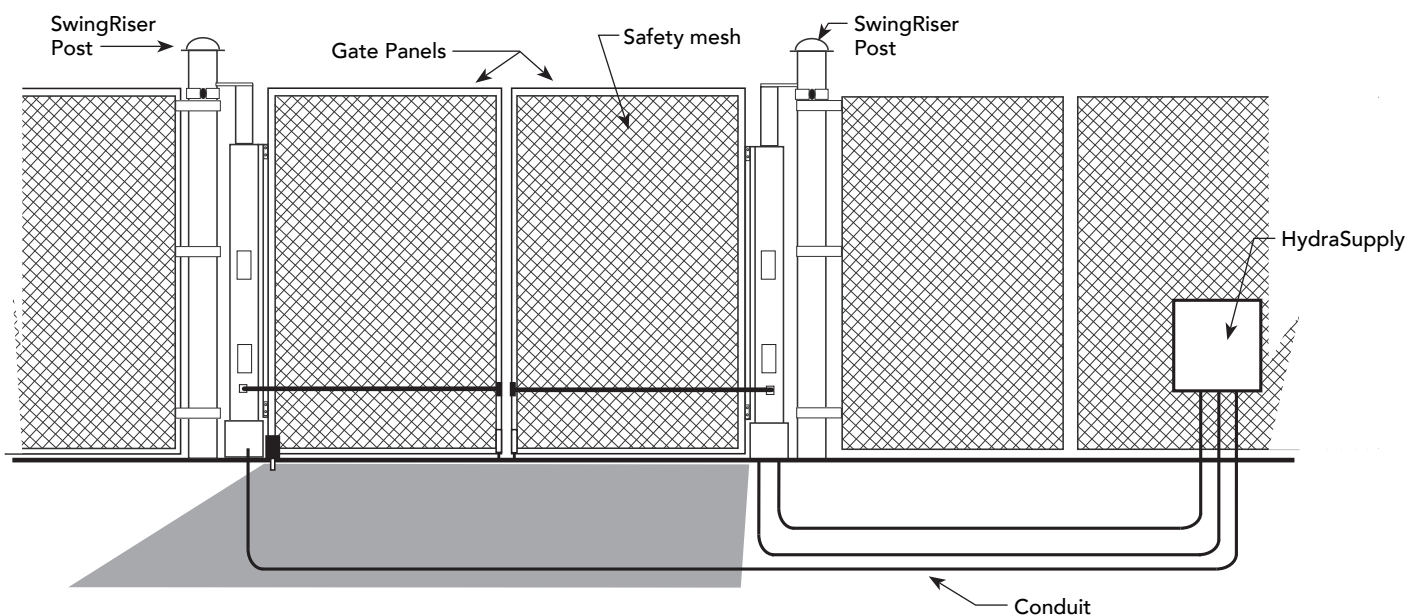

SWINGRISER POST: TOP CAP OPTIONS

A variety of top caps exist for wall or post mounts. The different types are illustrated in the SwingRiser order form. Be sure to order the appropriate Top Cap for your site.

4" Pipe Bracket

Use Restricted To 1000LB,
12' Long Gate Panels Max.

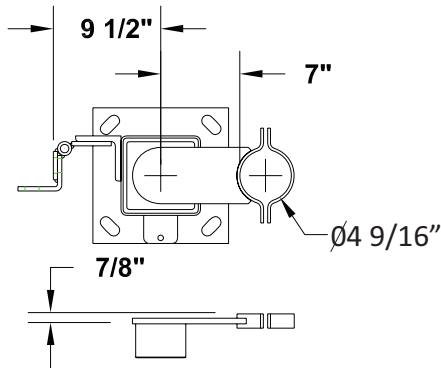

6" Pipe Bracket

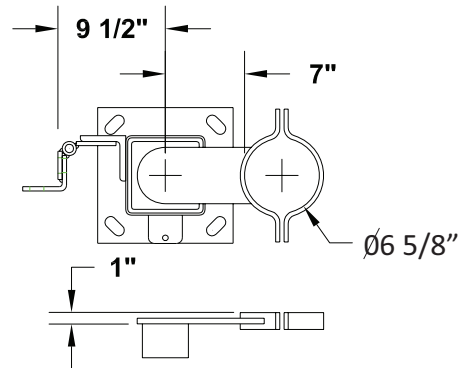

Pilaster Bracket

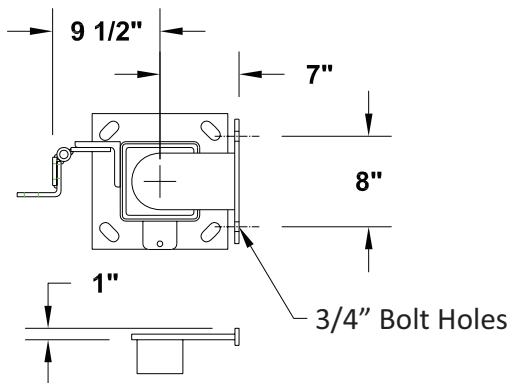

6" Sq Tube Bracket

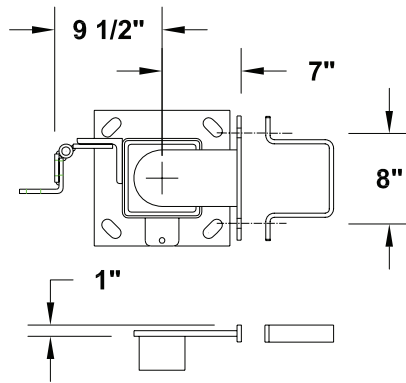

8" Pipe Bracket

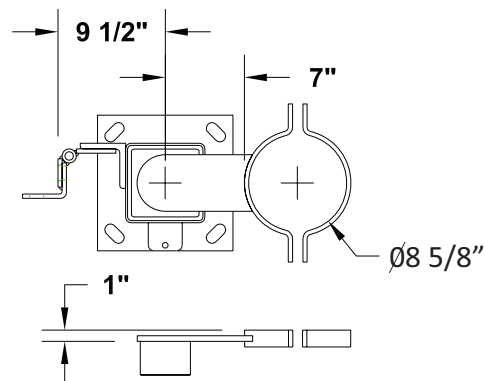

SWINGRISER POST: COMPONENTS

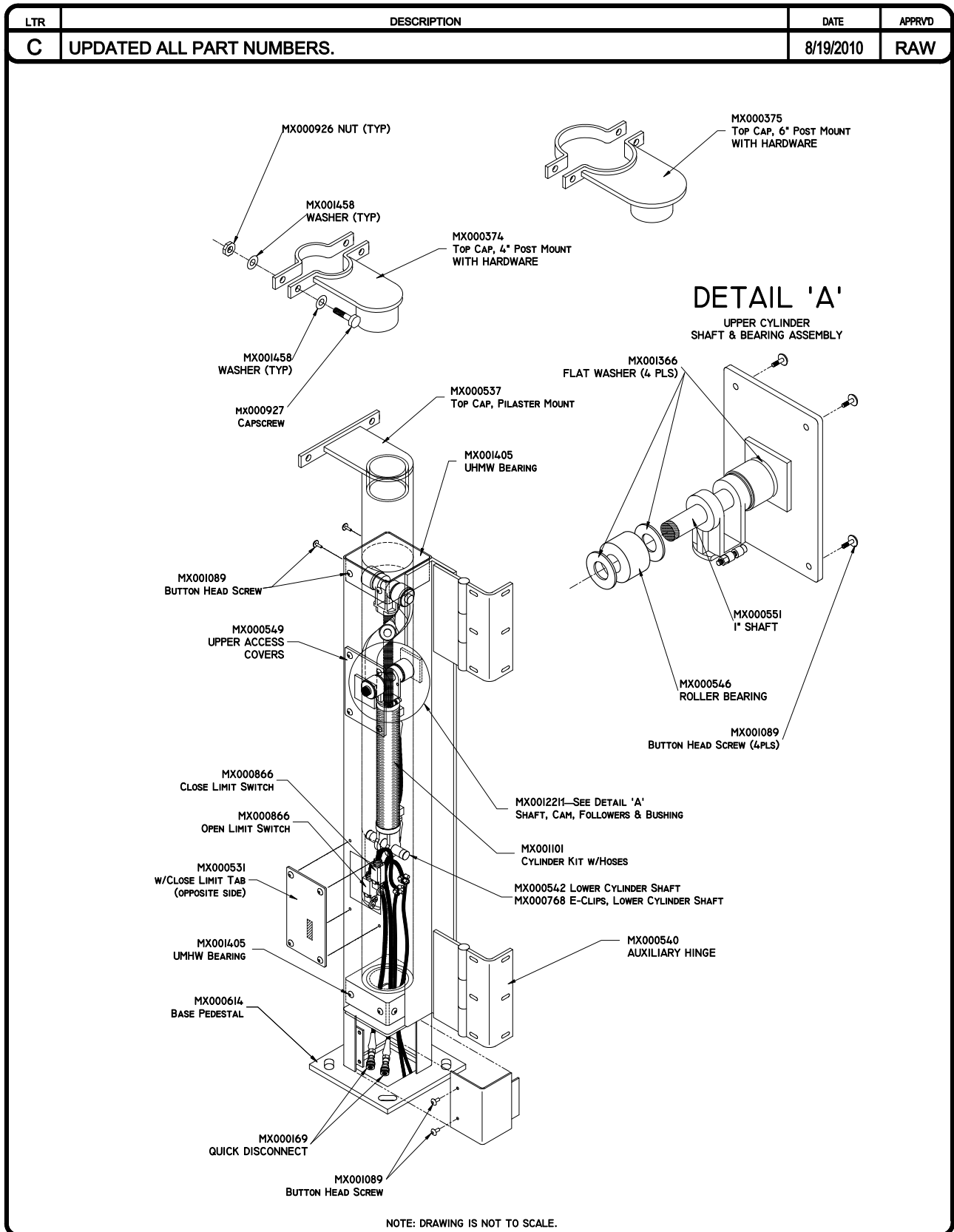

 <small>HySecurity Kent, Washington</small>	DOCUMENT TITLE	DRAWN	DATE	DOCUMENT NUMBER:	REV
	<h2 style="margin: 0;">SwingRiser</h2> <h3 style="margin: 0;">(HGR SWING GATE POST), TYP</h3>	—	10/05/1999	HR14	C
		CHECKED	DATE		
		APPROVED	DATE	SHT 1 OF 1	

SWINGRISER POSTS & INSTALLATION REFERENCE

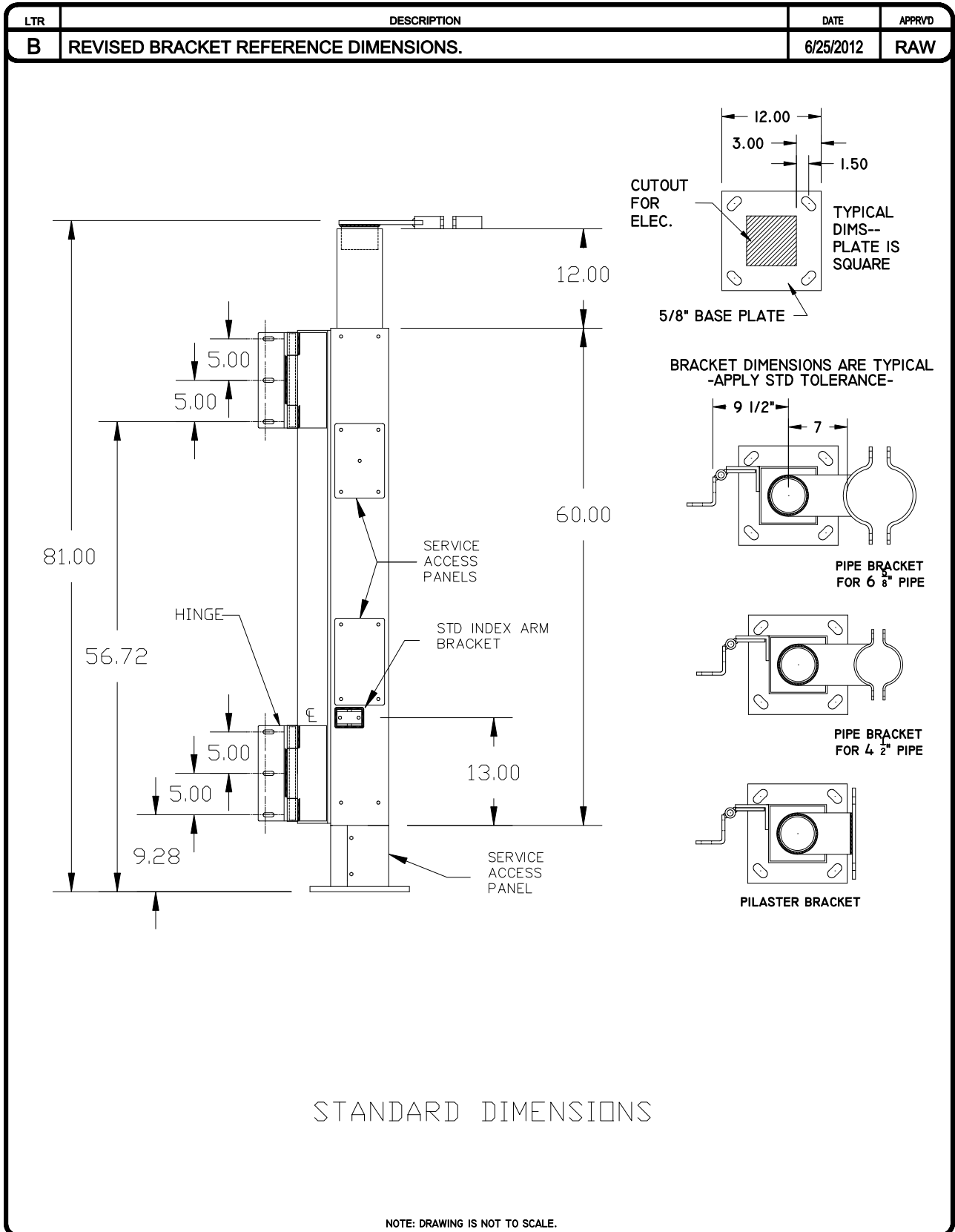

 HySecurity Kent, Washington	DOCUMENT TITLE	DRAWN	DATE	DOCUMENT NUMBER:		REV	
	SwingRiser DETAIL, (HRG POST) MODEL A	CMK	05/01/0000	HR39		B	
		CHECKED	DATE	THIRD ANGLE PROJECTION		SHT	OF
		APPROVED	DATE			1	1

SWINGRISER POSTS & GATE SITE: OVERVIEW

Illustrations show:

- Concrete pad dimensions
- Clearance requirements
- Anchor bolt locations
- Support post dimensions

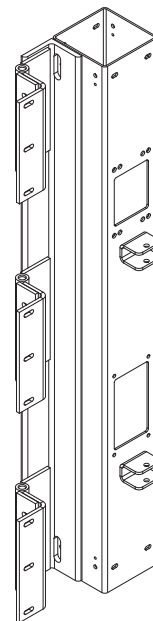
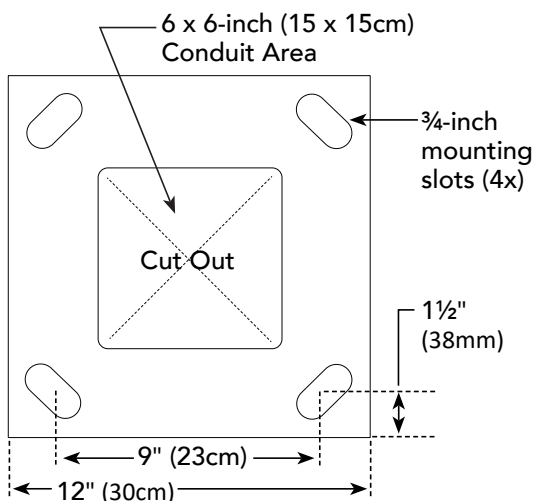
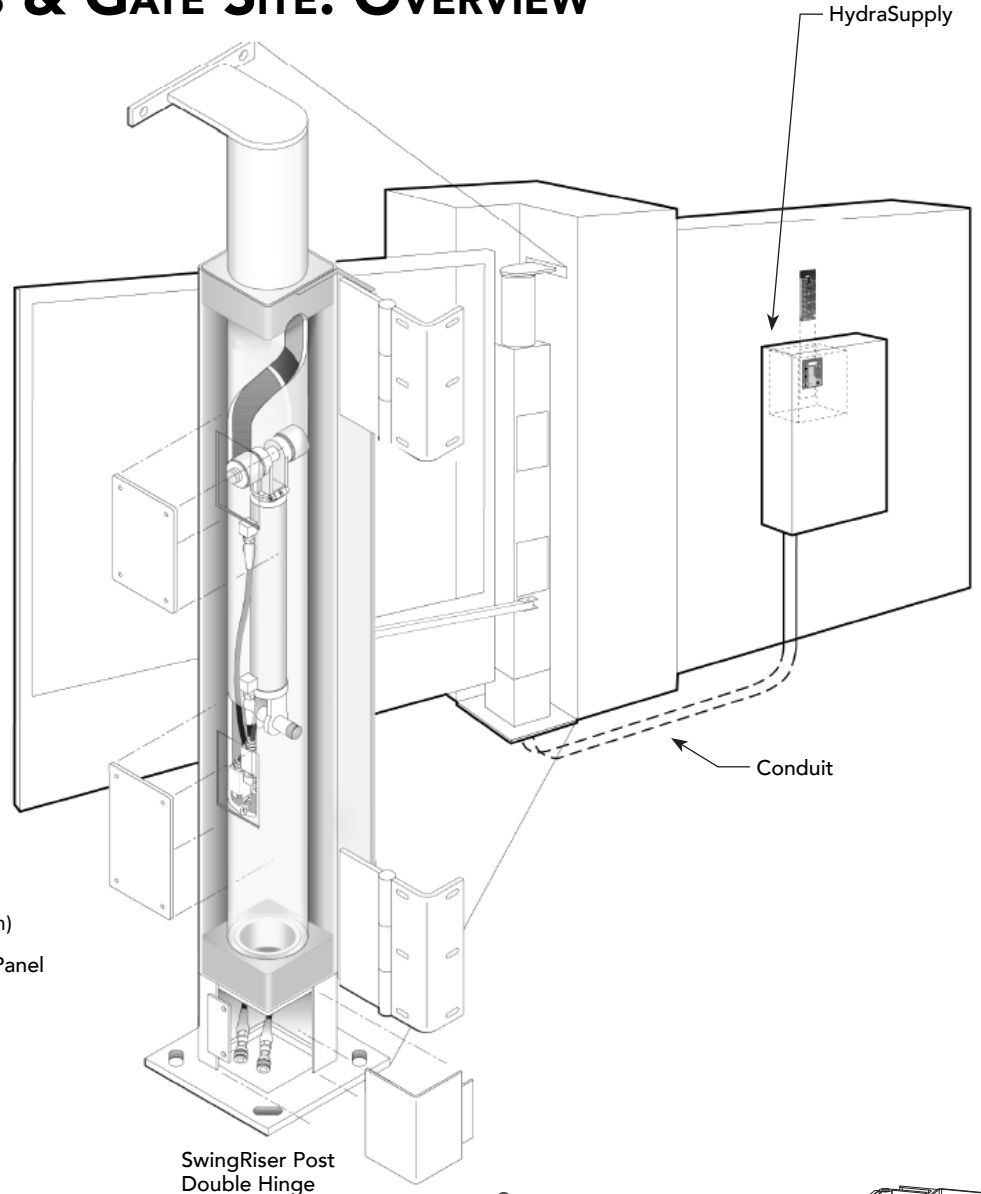
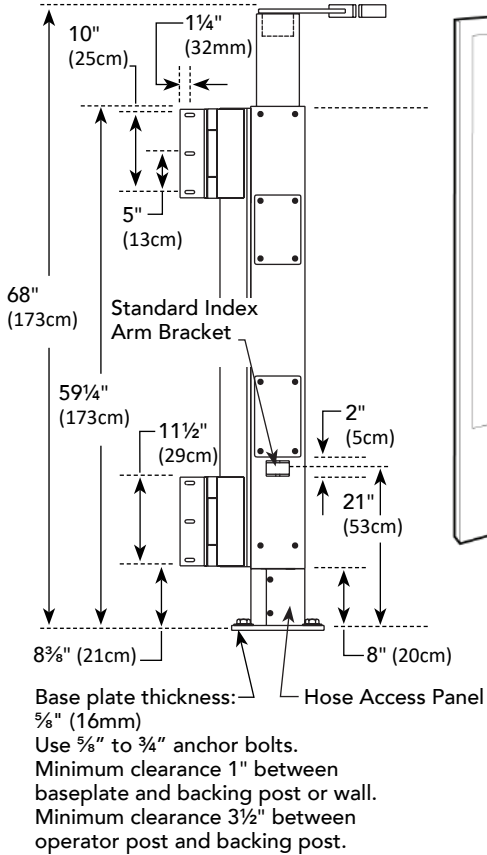

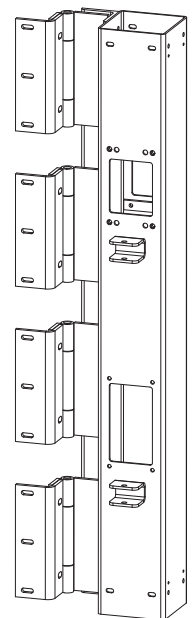

SwingRiser Post Triple Hinge

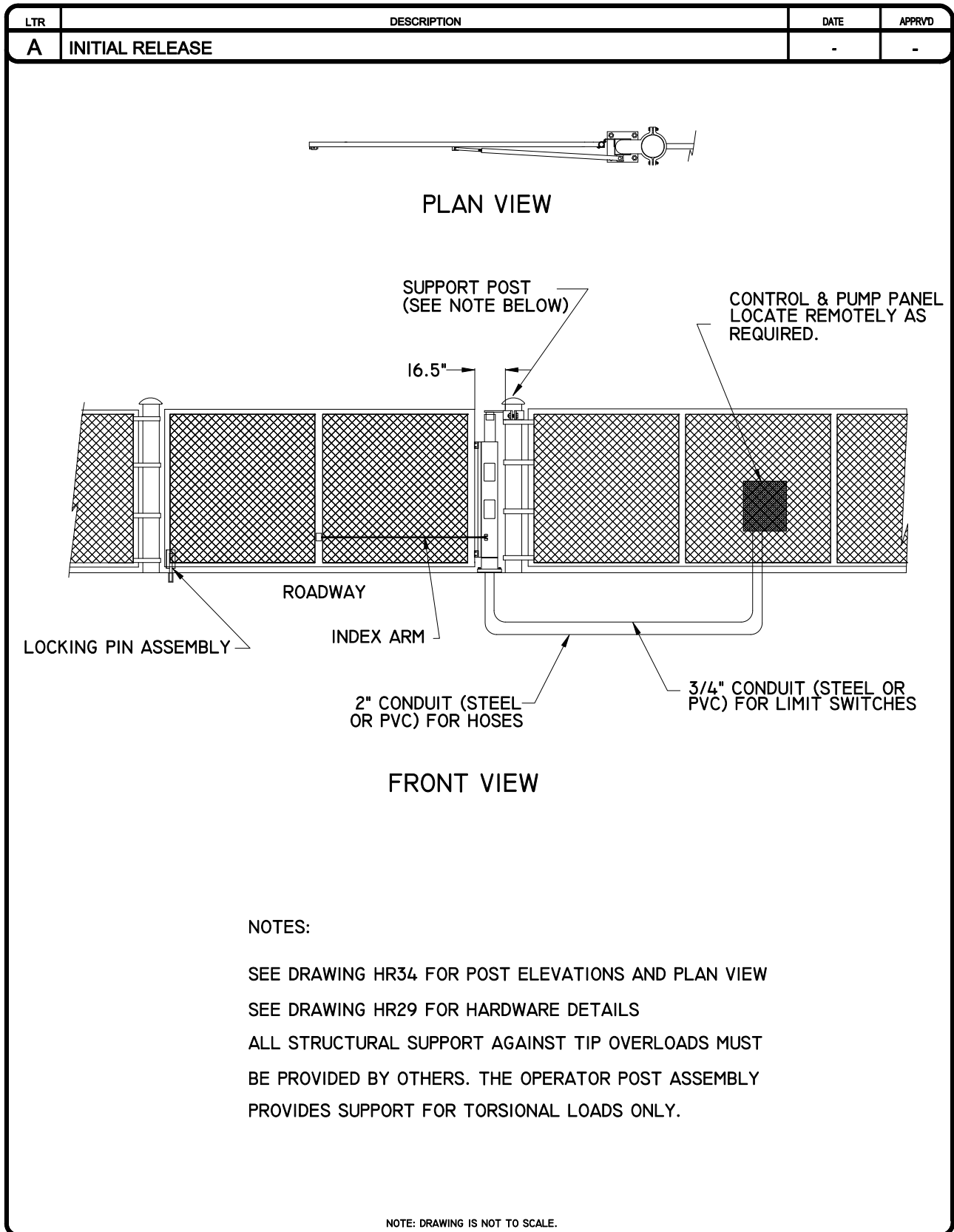

SwingRiser Post Quad Hinge

SWINGRISER SINGLE (HRG220): INSTALLATION REFERENCE



	DOCUMENT TITLE	DRAWN	DATE	DOCUMENT NUMBER:	REV
	SwingRiser Installation Reference (HRG 220) Single Gate Operator	STEVO	03/14/2001	HR32	A
		CHECKED	DATE	THIRD ANGLE PROJECTION	
		APPROVED	DATE	SHT	OF
		1	1		

SWINGRISER TWIN (HRG 222): INSTALLATION REFERENCE

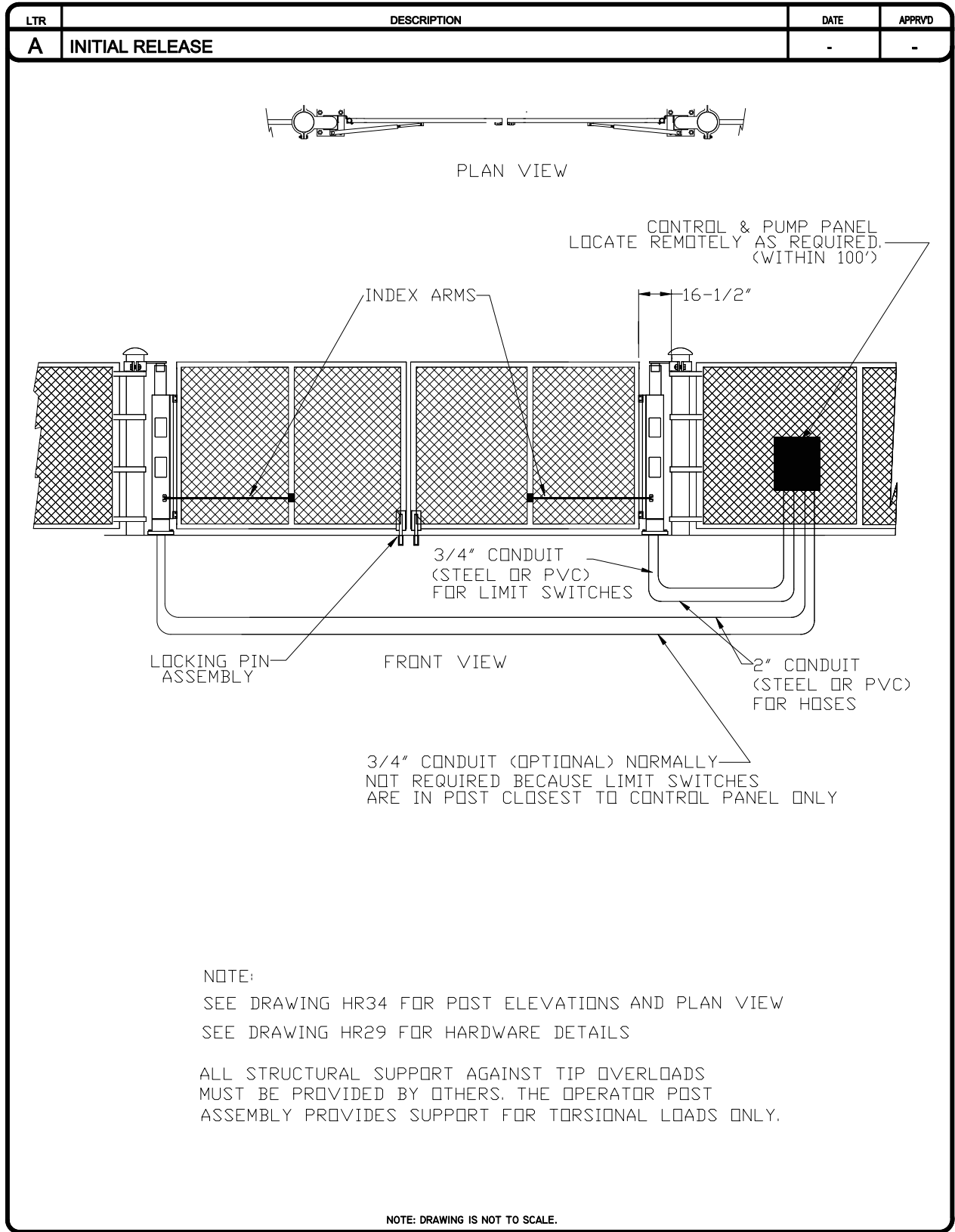

NOTE:

SEE DRAWING HR34 FOR POST ELEVATIONS AND PLAN VIEW
 SEE DRAWING HR29 FOR HARDWARE DETAILS

ALL STRUCTURAL SUPPORT AGAINST TIP OVERLOADS
 MUST BE PROVIDED BY OTHERS. THE OPERATOR POST
 ASSEMBLY PROVIDES SUPPORT FOR TORSIONAL LOADS ONLY.

 <small>HySecurity Kent, Washington</small>	DOCUMENT TITLE	DRAWN	DATE	DOCUMENT NUMBER:	REV
	SwingRiser Installation Reference (HRG 222) Twin Gate Operator	STEVEO	03/14/2001	HR33	A
		CHECKED	DATE		
		APPROVED	DATE	<small>THIRD ANGLE PROJECTION</small>	

SWINGRISER: INDEX ARM & LOCKING PIN OVERVIEW

LTR	DESCRIPTION	DATE	APPRVD
B	ADDED ARM ATTACHMENT MOUNT DIMENSION.	06/27/2014	RAW

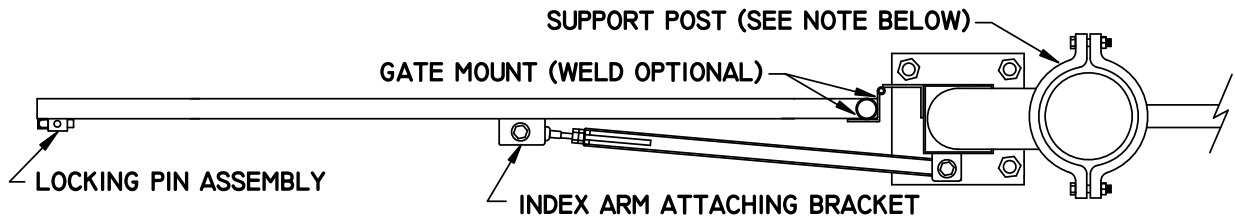

PLAN VIEW, GATE PANEL, OPERATOR POST, INDEX ARM AND LOCKING PIN

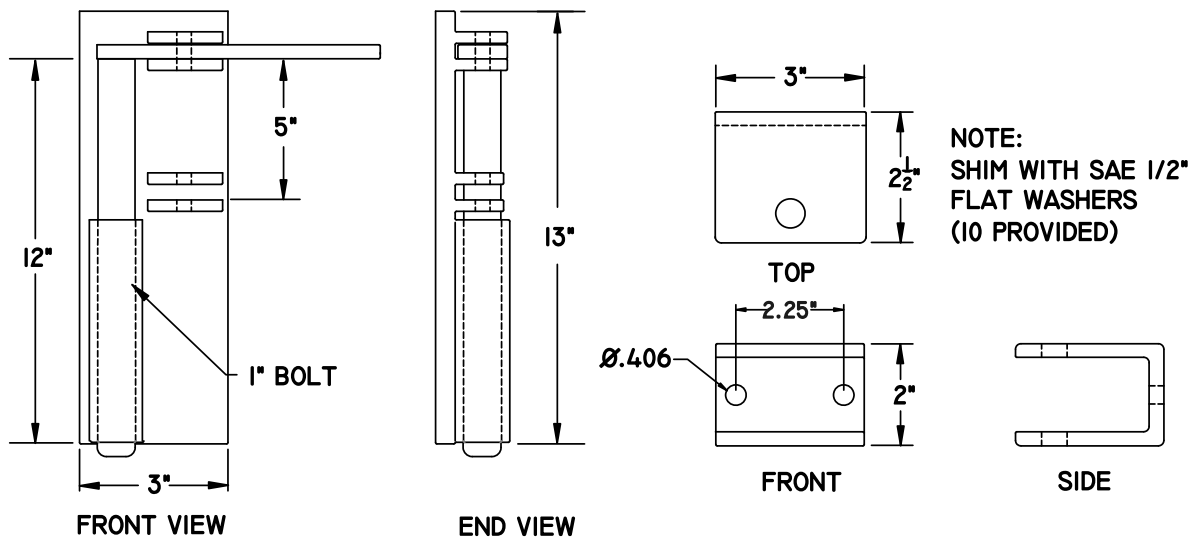

LOCKING PIN ASSEMBLY

ATTACHING BRACKET (GATE MOUNTED)

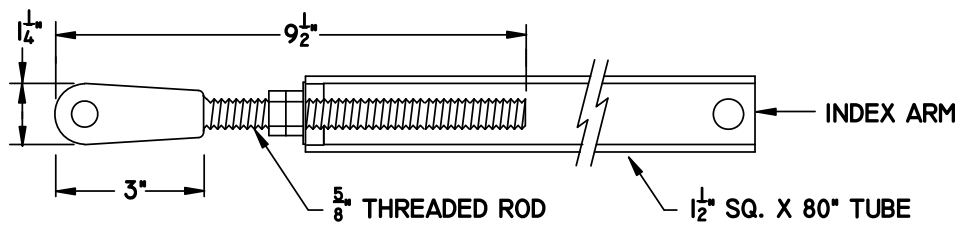

INDEX ARM EXTENTION

NOTE:
ALL STRUCTURAL SUPPORT AGAINST TIP OVERLOADS MUST BE PROVIDED BY OTHERS. THE OPERATOR POST ASSEMBLY PROVIDES SUPPORT FOR TORSIONAL LOADS ONLY.

NOTE: DRAWING IS NOT TO SCALE.

	DOCUMENT TITLE	DRAWN	DATE	DOCUMENT NUMBER:	REV
	INDEX ARM BRACKET AND LOCKING PIN FOR HRG OPERATOR	D.B.	05/08/00	HR29	B
		CHECKED	DATE		
		APPROVED	DATE	THIRD ANGLE PROJECTION	SHT OF
				1	1

SWINGRISER: POST MOUNT LOCKING PIN INSTALLATION

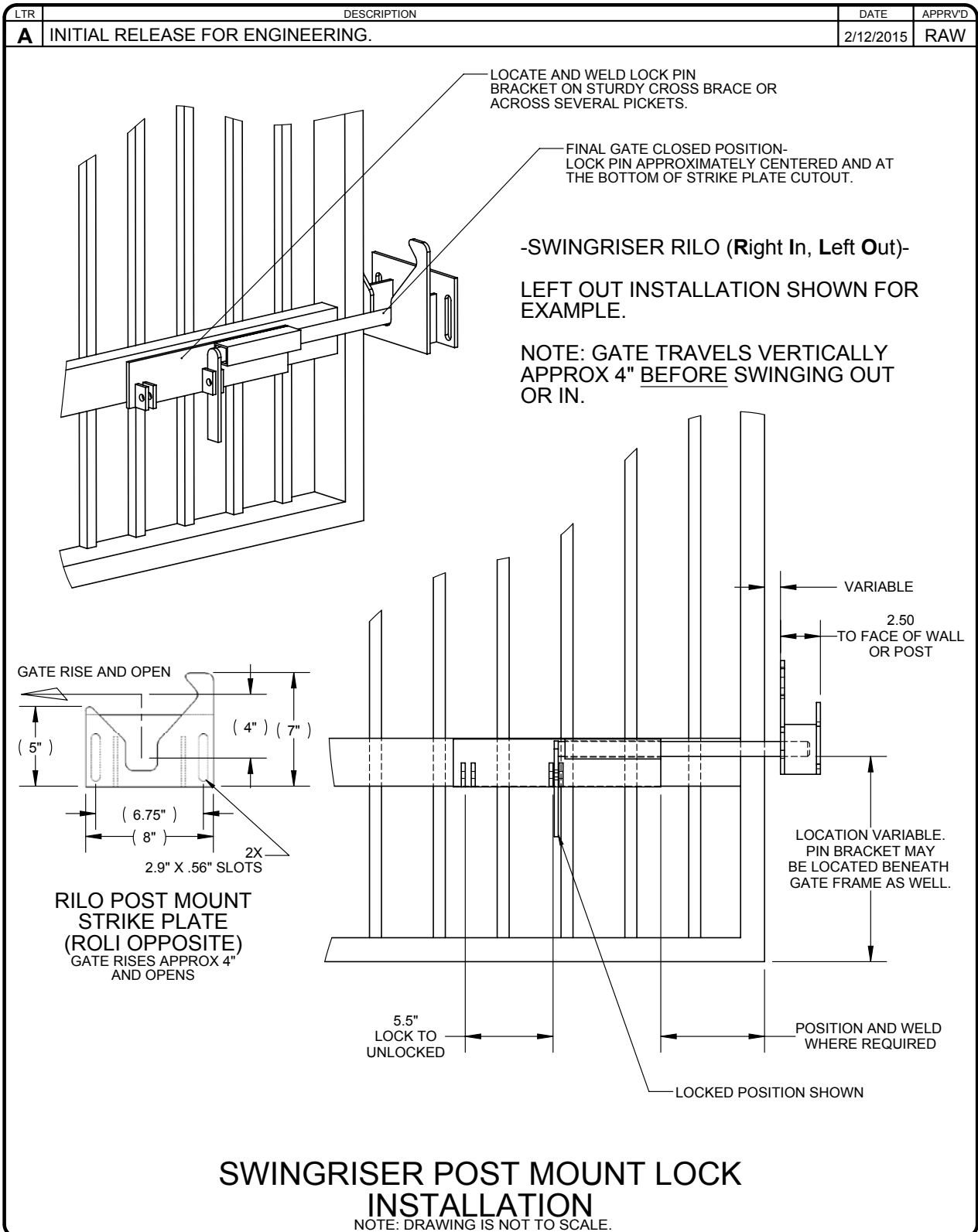

 HySecurity Kent, Washington	DOCUMENT TITLE	DRAWN	DATE	DOCUMENT NUMBER:	REV
	SWINGRISER LOCK INSTALLATION REFERENCE	RAW	6/18/2013	HR50	A
		CHECKED	DATE		SHT 1 OF 2
		APPROVED	DATE	THIRD ANGLE PROJECTION	

SWINGRISER: GROUND LOCKING PIN INSTALLATION

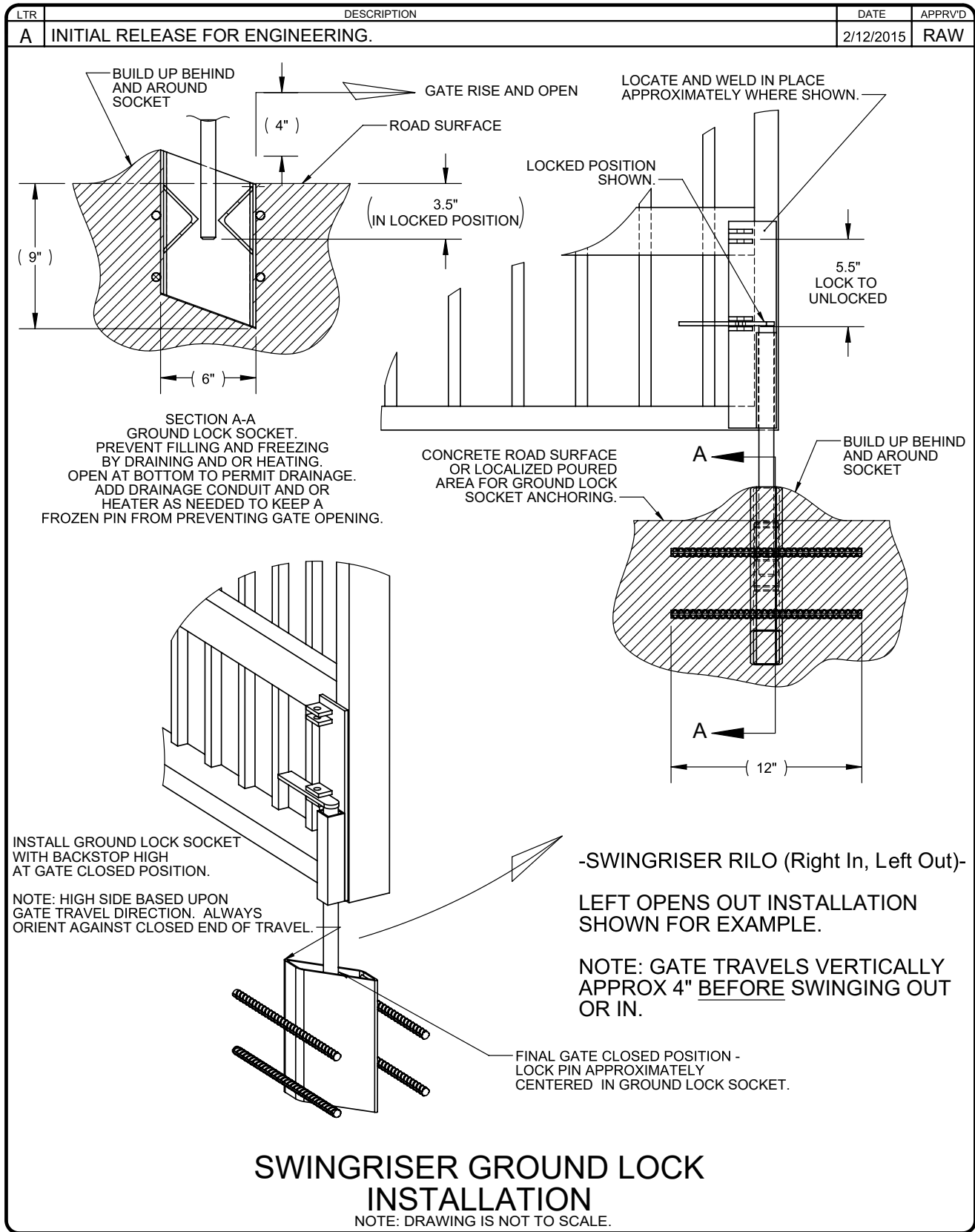

 HySecurity Kent, Washington	DOCUMENT TITLE	DRAWN	DATE	DOCUMENT NUMBER:	REV	
	SWINGRISER LOCK INSTALLATION REFERENCE	RAW	6/18/2013	HR50	A	
		CHECKED	DATE	THIRD ANGLE PROJECTION	SHT	OF
		APPROVED	DATE		2	2

SWINGRISER: HYDRASUPPLY INSTALLATION OVERVIEW

Wall or post-mount the HydraSupply cabinet (Type 3R). If planning a post mount, mounting holes need to be drilled (U-bolts, fasteners, and unistrut are not provided). Cabinet may also be wall-mounted with anchor bolts.

NOTE: The mounting holes on the top and bottom flanges are 5/16-inch diameter.

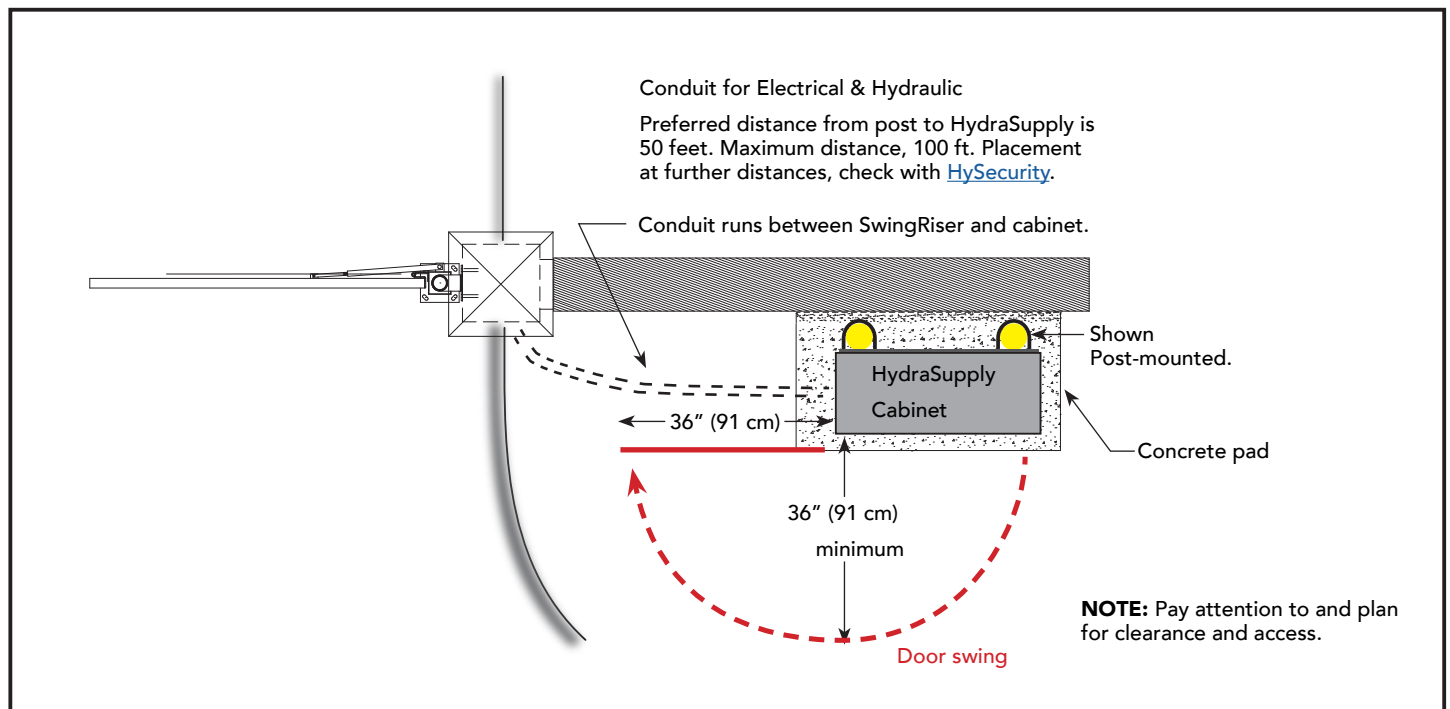
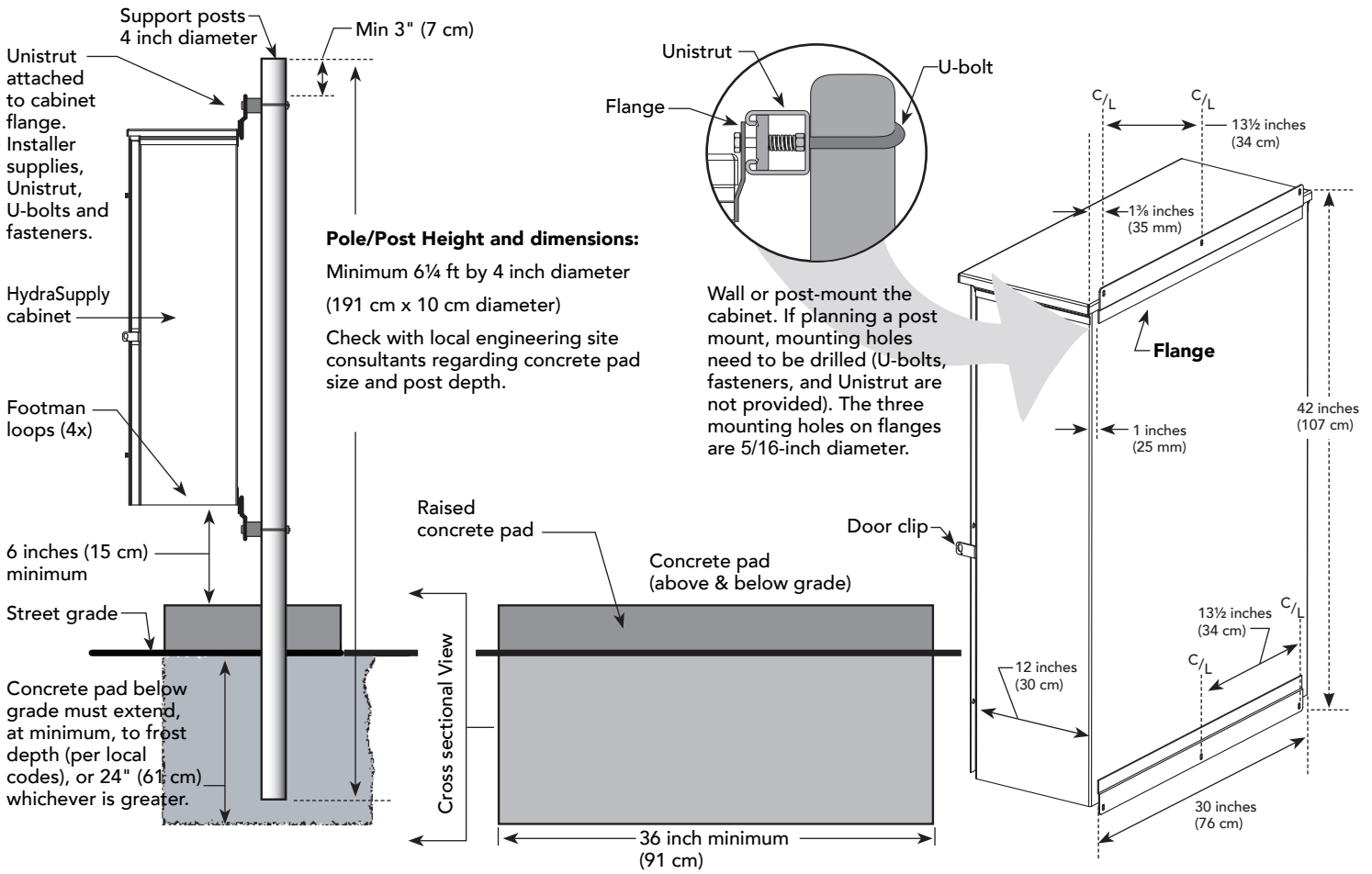

Page intentionally left blank

WARRANTY

1. Warranty.

HySecurity Gate, Inc. ("HySecurity") warrants that at the time of sale each of its products will, in all material respects, conform to its then applicable specification and will be free from defects in material and manufacture.

The following additional durational warranties apply to HySecurity products, depending on whether (1) the product is purchased through an authorized HySecurity distributor and (2) whether a timely and complete product registration is submitted to HySecurity.

It is therefore important that you register your product with HySecurity, online at www.hysecurity.com/warranty, within the 60-day period described below.

1(a) HySecurity Products Purchased Through Authorized Distributors and Properly Registered

For any gate operator product that is purchased from an authorized HySecurity distributor (this excludes product purchased through internet resellers or any distributor not authorized by HySecurity), if the product registration is completed by the Dealer/Installer/End User within 60 days of the date of purchase, the following warranty terms will apply. HySecurity warrants that the product will remain serviceable for the following periods:

- a. Hydraulic industrial gate operators hydraulics, controls, and mechanical components: Five Years or 500,000 gate cycles (whichever occurs first) after the date of installation,
- b. Hydraulic wedge operator hydraulics and controls: Five Years or 500,000 cycles (whichever occurs first) after the date of installation. Wedge mechanical components: Two Years after the date of installation,
- c. Electromechanical Slide and Swing operators: Five Years or 500,000 cycles (whichever occurs first) after the date of installation, except single family residential usage, where the warranty term shall be Seven Years after the date the product was shipped from HySecurity,
- d. Electromechanical surface mount wedge operator electronics: Two Years or 500,000 gate cycles (whichever occurs first), after the date of installation,
- e. Electromechanical Barrier Arm Operators: Two years or 1,000,000 gate cycles (whichever occurs first) after the date of installation,

provided that the preceding Five Year warranty period in (a), (b) and (c) will not extend beyond seven years from the date that the product was shipped from HySecurity, and the Two Year warranty period in (b), (d) and (e) will not extend beyond four years from the date that the product was shipped from HySecurity.

The preceding warranty durations do not apply to the products or components described below (f-i), which have a shorter warranty period.

- f. Hydraulic gate operator drive wheels including XtremeDrive™ wheels and rack: Two Years from date of installation.
- g. AC and DC power supplies, chargers and inverters and HyNet™ Gateway: Two Years from date of installation, except batteries.
- h. Batteries: One Year from date of shipment from HySecurity.
- i. Components subject to normal wear including, but not limited to, chains, belts, idler wheels, sprockets and fuses: One Year from date of installation.

1(b) HySecurity Products Not Purchased Through an Authorized Distributor or Not Properly Registered within 60 Days

For any product that is not purchased from an authorized HySecurity distributor or for which the product registration was not completed by the Dealer/Installer/End User within 60 days of the date of purchase, the following One-Year Limited Warranty will apply: HySecurity warrants that the product will remain serviceable for the following periods, which begin on the date that the product was shipped from HySecurity:

- a. All gate operators: One Year or 100,000 gate cycles whichever comes first.
- b. AC and DC power supplies, chargers or inverters: One Year.
- c. HyNet™ Gateway: One Year.
- d. Hydraulic gate operator drive wheels: One Year.

1(c) Replacement Parts

HySecurity warrants that replacement parts (whether new or reconditioned) will remain serviceable for One Year from the date that the product was shipped from HySecurity or the remaining period of the Gate Operator warranty, whichever is longer.

1(d) Limitations and Exclusions Applicable to Each of the Preceding Warranties.

The preceding warranties shall not apply to equipment that has been

- (1) installed, maintained, or used improperly or contrary to instructions;

- (2) subjected to negligence, accident, vandalism, or damaged by severe weather, wind, flood, fire, terrorism or war; or (3) damaged through improper operation, maintenance, storage or abnormal or extraordinary use or abuse. Any modification made to products will void the warranty unless the modifications are approved in writing by HySecurity in advance of the change (this exclusion does not apply to normal installation of approved accessories and/or protective devices or sensors). It is the responsibility of the distributor, installer, or End User to ensure that the software version in the product is maintained to the latest revision level.

The preceding warranties do not extend to accessories when those items carry another manufacturer's name plate and they are not a part of the base model. HySecurity disclaims all warranties for such accessory components, which carry only the original warranty, if any, of their original manufacturer. HySecurity hereby assigns its rights under such manufacturer warranties—to the extent that such rights are assignable—to Buyer.

These warranties extend to HySecurity's Distributors, to the Dealer/Installer, and to the first End User of the product following installation. They do not extend to subsequent purchasers.

2. Exclusion of Other Warranties.

The warranties contained in Section 1 are the exclusive warranties given by HySecurity and supersede any prior, contrary or additional representations, whether oral or written. Any prior or extrinsic representations or agreements are discharged or nullified. HYSECURITY HEREBY DISCLAIMS AND EXCLUDES ALL OTHER WARRANTIES—WHETHER EXPRESS, IMPLIED, OR STATUTORY—INCLUDING ANY WARRANTY OF MERCHANTABILITY, ANY WARRANTY OF FITNESS FOR A PARTICULAR PURPOSE, ANY LIABILITY, FOR INFRINGEMENT, AND ANY IMPLIED WARRANTIES OTHERWISE ARISING FROM COURSE OF DEALING, COURSE OF PERFORMANCE, OR USAGE OF TRADE.

3. Buyer's Exclusive Remedies for Any Nonconformity.

If a HySecurity product fails to conform to the warranties in Section 1, Buyer must notify and order replacement parts from the Distributor through which the product was purchased within a reasonable time and in no event more than thirty (30) days after the discovery of the nonconformity. HySecurity will investigate and, in the event of a breach, will provide, within a reasonable period of time, one of the following: (1) repair or replacement of any nonconforming products or components or (2) refund of the price upon return of the nonconforming items. HySecurity reserves the right to supply used or reconditioned material for all warranty claims. HySecurity will not be considered to be in breach of or default under this Warranty because of any failure to perform due to conditions beyond its reasonable control, including any force majeure. This warranty does not cover any incidental expenses, including fines or penalties, temporary security, labor, shipping, travel time or standby time that are incurred for inspection or replacement of any nonconforming items. As a condition of warranty coverage, warranty claims must be submitted in accordance with the procedures described on the HySecurity form, "RMA Procedures."

THE REMEDY SELECTED BY HYSECURITY IN ACCORDANCE WITH THIS PARAGRAPH SHALL BE **THE EXCLUSIVE AND SOLE REMEDY OF BUYER FOR ANY BREACH OF WARRANTY.**

4. Exclusion of Consequential and Incidental Damages.

HYSECURITY SHALL NOT BE LIABLE FOR ANY INCIDENTAL, SPECIAL, OR CONSEQUENTIAL DAMAGES, WHETHER RESULTING FROM NONDELIVERY OR FROM THE USE, MISUSE, OR INABILITY TO USE THE PRODUCT OR FROM DEFECTS IN THE PRODUCT OR FROM HYSECURITY'S OWN NEGLIGENCE. This exclusion applies regardless of whether such damages are sought for breach of warranty, breach of contract, negligence, or strict liability. This exclusion does not apply to claims for bodily injury or death.

5. Severability.

If any provision of this warranty is found to be invalid or unenforceable, then the remainder shall have full force and effect.

6. Proprietary Rights.

HySecurity retains and reserves all right, title, and interest in the intellectual property rights of its products, including any accompanying proprietary software. No ownership of any intellectual property rights in the products or accompanying software is transferred to Distributor, Dealer/Installer or End User.

7. Applicable Law.

This warranty will be interpreted, construed, and enforced in all respects in accordance with the laws of the State of Washington, without reference to its choice of law principles. The U.N. Convention on Contracts for the International Sale of Goods will not apply to this warranty.

SPECIFICATIONS

	1,000 lb gate, 14 second open		1,600 lb gate, 19 second open		3,000 lb gate, 30 second open	
	Single Leaf	Twin	Single Leaf	Twin	Single Leaf	Twin
Model	SwingRiser 14	SwingRiser 14-Twin	SwingRiser 19	SwingRiser 19-Twin	SwingRiser 30	SwingRiser 30-Twin
Part #	HRG 220-A ST	HRG 222-A ST	HRG 220-B ST	HRG 222-B ST	HRG 220-C ST	HRG 222-C ST
Duty Cycle	Continuous					
Horsepower	1 hp	2 hp	1 hp	2 hp	1 hp	2 hp
Drive	Hydraulic					
Gate Length Max.	Up to 9 ft (3 m) wide	Up to 9 ft (3 m) wide each leaf	Up to 16 ft (5 m) wide	Up to 16 ft (5 m) wide each leaf	Up to 16 ft (5 m) wide	Up to 16 ft (5 m) wide each leaf
Gate Weight Max.	1,000 lb (453 kg)	1,000 lb (453 kg) / leaf	1,600 lb (726 kg)	1,600 lb (726 kg) / leaf	3,000 lb (1,361 kg)	3,000 lb (1,361 kg) / leaf
Open/Close Time	14 seconds		19 seconds		30 seconds	
Temperature Rating	-40° to 158° F (-40° to 70° C) No heater necessary					
1 Phase Power	115/208/230V 60Hz 110/220V 50Hz	208/230V 60Hz 220V 50Hz	115/208/230V 60Hz 110/220V 50Hz	208/230V 60Hz 220V 50Hz	115/208/230V 60Hz 110/220V 50Hz	208/230V 60Hz 220V 50Hz
3 Phase Power	208/230/460V or 575V** 60Hz, 220/380/440V 50Hz					
Communication	RS-232, RS-485, Ethernet/fiber using optional HyNet™ Gateway accessory					
User Controls	Smart Touch Controller with 70+ configurable settings. Smart Touch keypad and display or a PC using S.T.A.R.T. software.					
Relays	Three configurable user relays: one 30VDC, 3A solid state and two 250VAC, 10A electromechanical. Optional Hy8Relay™ for 8 additional relay outputs					
Finish	Zinc flame sprayed					
Enclosure	HydraSupply: Type 3R, 30w x 42h x 12d inch (76w x 107h x 30.5d cm)					
ETL Listed (UL325)	Usage Class I, II, III, IV					
Warranty	5 year					

UPS Backup Power Options

DC Power Supply*	SwingRiser 14 UPS	SwingRiser 14-Twin UPS	SwingRiser 19 UPS	SwingRiser 19-Twin UPS	SwingRiser 30 UPS	SwingRiser 30-Twin UPS
AC Power Supply with HyInverter*	SwingRiser 14 with HyInverter	—	SwingRiser 14 with HyInverter	—	SwingRiser 14 with HyInverter	—

*The operator's normal duty cycle and the actual number of gate cycles available from battery depends upon gate resistance to travel, cycle length, battery size, state of charge and health, ambient temperature, accessory power draw and frequency of gate cycles during power outage. A 3/4 hp motor is standard on SwingRiser 19 UPS (HRG 220-B DC ST) and SwingRiser 30 UPS (HRG 220-C DC ST)

**575V 3Ø is special order

To enable fully automatic operation, this gate operator requires a MINIMUM of one external entrapment protection sensor to monitor potential entrapment zones in either the open or close direction of travel.

Copyright Notice

© Copyright 2017 by HySecurity Gate, Inc.

All rights reserved. No part of this manual may be reproduced by any means (photocopier, electronic, or mechanical), without the express written permission of HySecurity Gate, Inc. Federal copyright law prohibits the reproduction, distribution, or public display of copyrighted materials without the express written permission of the copyright owner, unless fair use or other exemption under copyright law applies. Additionally, HySecurity Gate, Inc. makes no representations or warranty with respect to this manual. We also reserve the right to make changes in the products described without notice and without any obligation to notify any persons of any such revision or change.

Trademarks

SlideDriver, StrongArm, SwingRiser, StrongArm CRASH, StrongArm M30, StrongArm M50, HydraLift, HydraSwing, HydraWedge SM50, HydraSupply XL, HydraSupply, HyNet, Hy8Relay, HyInverter AC, HyCharger DC, SlideWinder, Smart Touch, S.T.A.R.T., SwingSmart DC, SlideSmart DC, StrongArmPark DC, WedgeSmart DC, Smart DC and the HySecurity logo are trademarks or registered trademarks of HySecurity Gate, Inc.

UL and UL logo are trademarks of UL LLC and ETL is a trademark of Intertek.

Intertek provides the ETL Listed Mark.

Products called out in *Wiring HySecurity Sensors* are trademarks or registered trademarks of Miller Edge, Inc., OMRON Corporation, and Encon Electronics.