

Programming and Operations Manual

HydraLift™

10, 10F, 20, 20F

Vehicular vertical lift gate operator with Smart Touch Controller

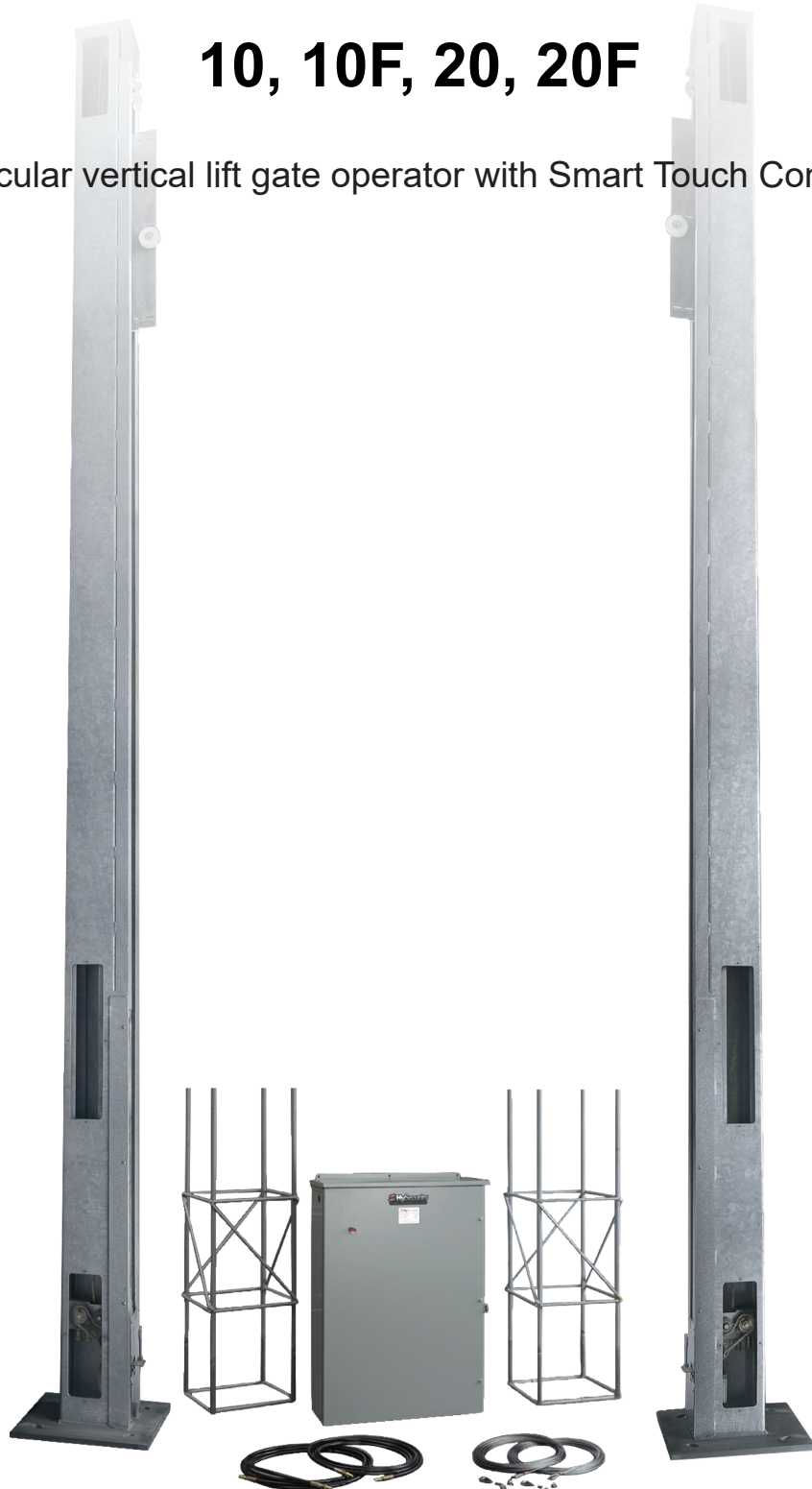

(This page intentionally blank)

TABLE OF CONTENTS

HydraLift:

- Table of Contents 3**
- Introduction 5**
- Models and Features 6**
 - Stopping the Gate 7
 - Starting the Gate 7
- Safety Information 9**
- Installation Preparation & Process 17**
 - Installation Preparation Checklist 17
 - Installation Process Overview 17
- HVG Pump and Electrical Panel 18**
 - HVG 420 Post Plan and Dimensions 19
 - HVG 460 Post Plan and Dimensions 20
 - Field Hose Measurements for HVG Operators 21
- Installation 22**
 - Limit Switch Setting/Wiring 25
 - Hose Connections 26
 - Manual Operation 27
- Operations 27**
 - Mechanical & Hydraulic Adjustments 28
 - Smart Touch Controller 29
 - STC Installation Configuration 30
 - STC Wiring Control Inputs 31
 - Smart Touch Controller Inputs 31
- Dual Gate 33**
- STC Controller User Menu 34**
 - Initial Power Up 34
 - System Data and User Menu Settings: 34
- User Menu Function Descriptions 38
 - Installer Menu Function Descriptions 39
 - User Programmable Output Relays 1-3 42
 - Clock Functions 44
 - Setting the Time and Date 44
- Entrapment Protection Device Schem. 45**
 - UL 325 Device Standard Requirements 46
 - Secondary Pedestrian Entrapment 47
 - Gate Reversing Edge Sensor Installation 48
 - General Information: 49
 - Compatibility: 49
 - Installation: 49
 - Configuration: 49
 - Connection: 49
 - Supervised Connection: 49
- Install Photo Eye (Non-Contact) Sensors 49**
 - Photo Eye Function: 50
 - Alignment: 50
 - Detector Basics 51
 - Loop Configurations 51
 - Rules to Follow for Security Gate Applications 51
- Detector Installation Guide 51**
 - Detector Logic 52

- Loop Diagnostics 52
- Test #1: 52
- Test #2: 52
- Vehicle Detector Loop Layout 53**
 - Vehicle Detector Installation Options 54
 - Hy5B Vehicle Detector Installation 55
 - Standard 11 Pin Box Type Vehicle Detector Install 56
 - Frequency: 57
 - Changing the Loop Frequency: 57
- Detector & Loop Fault Diagnostics 57**
 - Call Strength Level: 58
 - Standard and Anti-tailgate modes 59
 - Vehicle Detector Config & Anti-Tailgate 59
 - STC 24hr/7day Timer Connection 60
 - Selecting AM/PM or Military Time 60
 - Setting the Time 60
 - Programming 24 hours or 7 day schedules 60
 - Reviewing Programs 61
 - Manual Override 61
 - STC 24hr/7day Timer Connection 61
 - Connecting a Radio Receiver 62
 - Trouble With Gate Movement in General: 63
 - Electrical Problems in General: 63
 - Specific Types of Problems: 63
- Troubleshooting 63**
 - Operator Post 67
 - Hydraulic System 67
- General Maintenance: 67**
 - Electrical Controls 68
 - Pressure Relief Valves Adjustment Procedures 68
 - Vertical Gate Operator Maintenance Schedule 69
 - Maintenance Schedule 69
 - D.C. Operator Wiring & Control Config 71
 - Battery Connection Diagram 72
 - Wire Size Schedules 74
 - HVG Pump Packs - Parts Breakout 76
 - HVG EX Pump Packs - Parts Breakout 77
 - Parts Breakout – HVG Control Box 78
 - Parts Breakout - DC Power Supply 79
- Appendix A - French Translations 83**
- Warranty 87**
- Specifications 88**

NOTICE

Visit <https://hysecurity.com/technical-support/> for installation manuals, replacement part instructions, part diagrams and more.

MODELS AND FEATURES

- HVG 420—1000 lb. capacity.
- HVG 460—2000 lb. capacity.
- Gate widths to 80 feet possible.
- Reliable Hydraulic Mechanism.
- Rated for continuous duty.
- Both towers are driven.
- Sixteen-foot opening height standard.
- 24 foot tower standard,
- Custom heights available.
- Gate is fully counterweighted with concealed weights.
- Extremely low maintenance.
- Operates within its own footprint.
- Power pack and electric panel are designed to be remotely located within one hundred feet.
- Operator post is treated with an industrial galvanized finish to provide excellent corrosion resistance.
- All components are designed for easy removal during service.
- The hydraulic system features the latest technology, modular manifolds and individually replaceable cartridge valves.
- Fully compatible with all standard access control equipment.
- Accessories include heaters, timers, detectors, photo eyes, gate edges, release for manual operation, hand pumps, and master/slave units.
- Extended five-year Limited Warranty

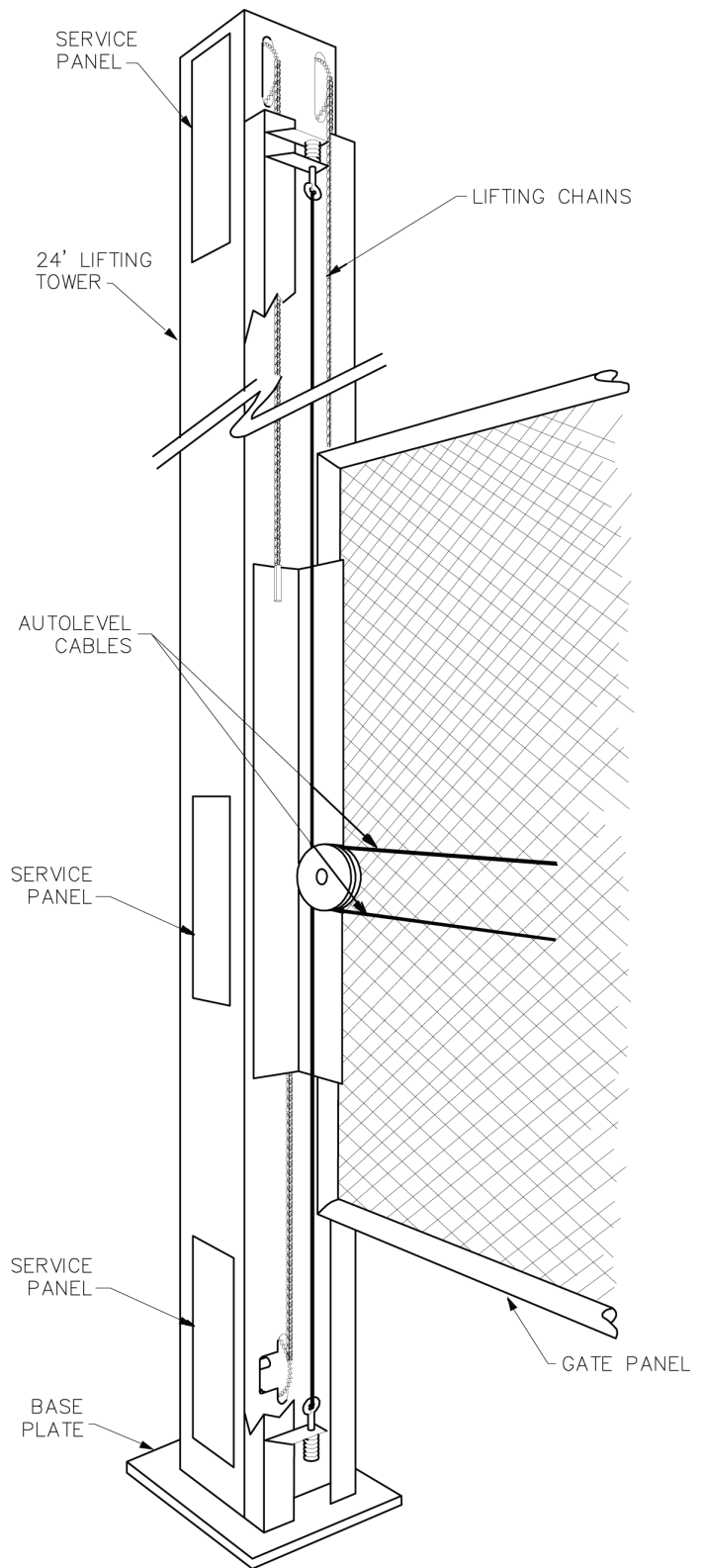

Figure 1. Models and Features

MODELS AND FEATURES

Vertical lift gates solve many problems that vex security designers. Vertical lift gates need no extra room to swing or slide, and are extremely very reliable because of the simple drive mechanism in each post. Vertical movement is another design advantage since a very large gate panel can be opened and closed in only sixteen seconds. A vertical lift gate is also very secure and is therefore an excellent choice for a prison application. We can accommodate gates up to 80' in width and 2,000 pounds. Our standard vertical travel is sixteen feet to allow clearance for trucks. No other design is this flexible.

Only the finest materials and workmanship go into our hydraulic vertical lift towers. They are steel construction, finished with zinc coating for corrosion protection, and come pre-assembled, ready to install between buildings or in other tight areas where space is at a premium. All hardware is enclosed and protected from the elements. The vertical lift operators can handle gate weights up to one ton. All units are fully counterweighted and, like all Hy-Security equipment, self-locking.

Take a moment to identify the operator model you have and note there are some changes in the instructions, especially in regards to final adjustments. The following chart shows the differences at a glance:

Table 1. Models and Features

Operator	HVG 420 / HVG 420 DS	HVG 420 EX / HVG 420 DX	HVG 460 / HVG 460 DS	HVG 460 EX / HVG 460 DX
Gate Panel Capacity	1000 lbs.	1000 lbs.	2000 lbs.	2000 lbs.
Horsepower	2 HP	5 HP	2 HP	5 HP
Rate of Travel 1	1 ft/sec	2 ft/sec	1 ft/sec	2 ft/sec
UL Usage Class	1-4	3-4	1-4	3-4
Warranty	5 years	5 years	5 years	5 years
Soft Stop	Yes	Yes	Yes	Yes
Brake Valves	Yes	Yes	Yes	Yes
Soft Start	No	Yes	No	Yes
Tower Size Post Height Diameter	Opening ht: 16 ft. 24 ft. 10 in ²	Opening ht: 16 ft. 24 ft. 10 in ²	Opening ht: 16 ft. 24 ft. 10 in ²	Opening ht: 16 ft. 24 ft. 10 in ²

STOPPING THE GATE

All models employ a time delay **Soft Stop** system. Additionally, hydraulic brake valves (shown at right) are used to control the stopping of heavy or fast moving gates. These valves are exclusive to Hy-Security operators. They are independently adjustable to allow the gate to stop predictably and without banging.

STARTING THE GATE

When starting very heavy gates to accelerate faster than one foot per second, it is necessary to **Soft Start** the load gently, in addition to stopping it smoothly. Soft Start is accomplished by another Hy-Security exclusive feature we call an AWOG, which diverts some of the start-up hydraulic flow and thereby allows the gate to accelerate over a period of about 2 seconds. This is much like letting your foot slowly off a car clutch – no lurching when the gate starts. The AWOG definitely improves the life and performance of a gate system and never needs adjustment.

MODELS AND FEATURES

Designed for Large Gates

More secure and reliable than a cantilever slide gate system. A perfect solution for large gates with limited space to open.

Fast Opening

Standard operator clears a sixteen-foot opening in sixteen seconds—The EX version clears the same opening in just eight seconds.

Reliable in Snowy Conditions

Snowdrifts can't stop a vertical lift gate from opening.

Smooth Operation

Autolevel system prevents gate becoming wedged or jammed.

Remote Power Pack

Hydraulic Power pack and electric panel remotely located up to 100' from post.

Heavy Duty Lifting

HVG 420 lifts up to 1000 pounds, HVG 460 lifts up to 2000 pounds.

Built to Last with Quality Components

Time lost to maintenance and repairs is drastically reduced.

Versatile

Ideal for installations with restricted side space. Widths determined only by construction of gate panel and total weight.

Extraordinarily Secure

Vertical Lift Operators are widely used in prisons and other secure facilities.

DC 24-Volt UPS (Uninterruptible Power Supply) Operators

These gate operators function from 24 Volts DC Batteries all of the time to achieve a true UPS system. Our **Uninterruptible Power Supply** is the most certain way to know that your gate will work when the local AC power fails. This system features fully sealed maintenance free batteries in a separate insulated and ventilated enclosure. A two-battery version provides at least 3,000 feet of backup gate travel. A fourbattery version provides at least 8,000 feet of backup travel during local power loss.

The Smart Touch Controller

This is the brain of the all Hy-Security's automatic operators. Truly high technology, but is also very rugged to reliably serve in the harsh environments that exist in the real world. The Smart Touch Controller is also very smart and can quickly be configured by an installer or user to adapt to about any functional requirement of a specific site. All system settings are performed with the use of just four programming buttons and an LCD display. The Smart Touch Controller has no switches of any type to set. An RS232 port is for external communication is standard. The system also has a real time clock and an EEPROM to record system events. The log of events can be downloaded from the RS232 port with a PC computer or a PDA with the Palm OS. Our optional vehicle detector modules set a new industry standard by communicating a host of valuable performance data to the microprocessor in the Smart Touch Controller via a serial data stream, allowing user-friendly diagnostics.

SAFETY INFORMATION

SAFETY MESSAGES

The safety messages below inform you about potential hazards that can result in injury. Safety messages specifically address level of exposure to operator and are preceded by one of four words: **DANGER, WARNING, CAUTION** or **NOTICE**.

 **DANGER**

Indicates a hazardous situation which, if not avoided, **WILL** result in **DEATH** or **SERIOUS INJURY**.

 **WARNING**

Indicates a hazardous situation which, if not avoided, **COULD** result in **DEATH** or **SERIOUS INJURY**.

 **CAUTION**





Indicates a hazardous situation which, if not avoided, **COULD** result in **MINOR** or **MODERATE INJURY**.

NOTICE

Addresses practices not related to personal injury. Indicates damage to equipment is probable if the hazardous situation is not avoided.

COMMON INDUSTRIAL SYMBOLS

These international safety symbols may appear on product or in its literature to alert of potential personal injury hazards. Obey all safety messages that follow these symbols to avoid possible injury or death.

Symbol	Safety Hazard
	Attention - Take Notice
	Danger - Keep Away
	Entrapment Zone
	Possible Pinch Point

IMPORTANT SAFETY INSTRUCTIONS

Hazards, associated with automatic gates, can be reduced with proper site design, installation, and use. Installers, maintenance crews, and owners/users must read and follow the safety requirements found in HySecurity® product manuals.



It is important that only qualified installers handle installation of HySecurity Gate vehicular gate operators. A “qualified” installer has one of the following:



1. A minimum of three years experience installing similar equipment.
2. Proof of attending a HySecurity Technical Training seminar within the past three years.
3. Significant manufacturer endorsements of technical aptitude in gate operator installation and operation.

Underwriter Laboratories (UL) and the American Society for Testing and Materials (ASTM) are responsible for current safety standards and regulations regarding gate operators and automated gates. All aspects of gate installation must comply with the appropriate safety standard. For the most up-to-date ASTM F2200 Gate and Fence Standards, refer to www.astm.org. For UL 325 Safety Standard, refer to www.ul.com. Consult local government agencies for up-to-date rules and regulations as certain municipalities have established licensing, codes or regulations that regulate automated gate system design and installation.

GENERAL SAFETY INFORMATION

A gate operator is only a component in a gate system. The other parts of the gate system can include the gate, the external safety sensors, access controls, and vehicle detectors. To have a gate system that provides for safety, security, and reliable operation it is essential these components operate together as a system. It is the responsibility of the system designer and/or installer to ensure any safety or operational issues have been addressed.



WARNING

To reduce the risk of injury or death:

1. READ AND FOLLOW ALL INSTRUCTIONS.
2. Never let children operate or play with gate controls. Keep the remote control away from children.
3. Always keep people and objects away from the gate. NO ONE SHOULD CROSS THE PATH OF THE MOVING GATE.
4. Test the gate operator monthly. The gate MUST reverse on contact with a rigid object or stop when an object activates the non-contact sensors. After adjusting the force or the limit of travel, retest the gate operator. Failure to adjust and retest the gate operator properly can increase the risk of injury or death.
5. Use the emergency release only when the gate is not moving.
6. KEEP GATES PROPERLY MAINTAINED. Read the user's manual. Have a qualified service person make repairs to gate hardware.
7. The entrance is for vehicles only. Pedestrians must use separate entrance.
8. SAVE THESE INSTRUCTIONS.

IDENTIFYING GATE OPERATOR CATEGORY AND UL 325 USAGE CLASS

The UL 325 standard covers gate operators. Within this safety standard several Usage Classes are described that define different types of installations where gate operators can be applied. Some operators are restricted in their usage application. Appropriate Usage Classes are shown in the Specifications.

Class I



Class I: Intended for use in a location of one to four single family dwellings or a parking area associated with one to four single family dwellings.

Class II



Class II: Intended for use in a commercial location or building such as a multi-family housing units (five or more single family units) hotels, garages, retail stores or other buildings servicing general public.

Class III



Class III: Intended for use in an industrial location or building such as factories or loading docks or other locations not accessible by the general public.

Class IV



Class IV: Intended for use in guarded industrial locations or buildings such as an airport security area or other restricted access location, not servicing general public, in which access is monitored by security personnel or via closed circuitry.

VEHICULAR TRAFFIC ONLY

WARNING

This automatic gate operator is not designed nor is it intended for pedestrian traffic. Vehicular gate operators must by their nature be powerful to function reliably. This power can cause injury or death. Accordingly, direct all pedestrian traffic to a separate walk-through gate.

Install this gate operator only when:

- The operator is appropriate for the construction of the gate and the usage Class of the gate.
- All openings of a horizontal slide gate are guarded or screened from the bottom of the gate to a minimum of 1.83 m (6 ft) above the ground to prevent a 57.2 mm (2-1/4 in) diameter sphere from passing through the openings anywhere in the gate, and in that portion of the adjacent fence that the gate covers in the open position.
- All exposed pinch points are eliminated or guarded.
- Guarding is supplied for exposed rollers.

The operator is intended for installation only on gates used for vehicles. Pedestrians must be supplied with a separate access opening. The pedestrian access opening shall be designed to promote pedestrian usage. Locate the gate such that persons will not come in contact with the vehicular gate during the entire path of travel of the vehicular gate.

The gate must be installed in a location so that enough clearance is supplied between the gate and adjacent structures when opening and closing to reduce the risk of entrapment. Swinging gates shall not open into public access areas.

The gate must be properly installed and work freely in both directions prior to the installation of the gate operator. Do not over-tighten the operator clutch or pressure relief valve to compensate for an improperly installed, improperly functioning, or damaged gate.

Permanently mounted controls intended for user activation must be located at least 1.83 m (6 ft) away from any moving part of the gate and where the user is prevented from reaching over, under, around or through the gate to operate the controls.

- Exception: Emergency access controls only accessible by authorized personnel (e.g. fire, police, EMS) may be placed at any location in the line-of-sight of the gate.

The Stop and/or Reset button must be located in the line-of-sight of the gate. Activation of the reset control shall not cause the operator to start.

A minimum of two (2) WARNING SIGNS shall be installed, in the area of the gate. Each placard is to be visible by persons located on the side of the gate on which the placard is installed.

For gate operators utilizing a non-contact sensor (Photo Eye):

- See instructions on the placement of non-contact sensors for each type of application.
- Care shall be exercised to reduce the risk of nuisance tripping, such as when a vehicle trips the sensor while the gate is still moving.
- One or more non-contact sensors shall be located where the risk of entrapment or obstruction exists, such as the perimeter reachable by a moving gate or barrier.

For a gate operator utilizing a contact sensor (Edge):

- One or more contact sensors shall be located where the risk of entrapment or obstruction exists, such as at the leading edge, trailing edge, and postmounted both inside and outside of a vehicular horizontal slide gate.
- A hardwired contact sensor shall be located and its wiring arranged so that the communication between the sensor and the gate operator is not subjected to mechanical damage.
- A wireless device such as one that transmits radio frequency (RF) signals to the gate operator for entrapment protection functions shall be located where the transmission of the signals are not obstructed or impeded by building structures, natural landscaping or similar obstruction. A wireless device shall function under the intended end-use conditions.
- One or more contact sensors shall be located on the inside and outside leading edge of a swing gate. Additionally, if the bottom edge of a swing gate is greater than 152 mm (6 in) but less than 406 mm (16 in) above the ground at any point in its arc of travel, one or more contact sensors shall be located on the bottom edge.

USE OF VEHICLE DETECTORS

Use of vehicle detectors (loop detectors) is strongly encouraged to prevent damage to vehicles caused by gates closing on them. This is not considered to be a safety item as vehicle detectors cannot provide protection to pedestrians. In some situations, photoelectric devices may be used as vehicle detectors, but should be wired accordingly.

GATE CONSTRUCTION AND SAFETY

Gate construction plays a very important role in ensuring the safety of any automated gate system. The standard for gate construction is ASTM F2200. Below are key areas to address in gate design for safety. For complete information consult the standard. Copies of the standard are available at:

<https://www.astm.org/Standards/F2200.htm>

SAFETY INFORMATION

Another source of information is available from DASMA, the Door and Access System Manufacturer's Association. The Association publishes Technical Data Sheets, one of which concerns ASTM F2200. For more information, see:

<http://www.dasma.com/PDF/Publications/TechDataSheets/OperatorElectronics/TDS370.pdf>.

General Requirements for gate construction:

- Gates shall be constructed in accordance with the provisions given for the appropriate gate type listed. Refer to ASTM F2200 for additional gate types.
- Gates shall be designed, constructed and installed to not fall over more than 45 degrees from the vertical plane, when a gate is detached from the supporting hardware.
- Gates shall have smooth bottom edges, with vertical bottom edged protrusions not exceeding 0.50 in (12.7 mm) other than the Exceptions listed ASTM F2200.
- The minimum height for barbed wire shall not be less than 6 ft (1.83 m) above grade. The minimum height for barbed tape shall not be less than 8 ft (2.44 m) above grade.
- An existing gate latch shall be disabled when a manually operated gate is retrofitted with a powered gate operator.
- A gate latch shall not be installed on an automatically operated gate.
- Protrusions shall not be permitted on any gate. Consult ASTM F2200 for exceptions.
- Gates shall be designed, constructed and installed such that their movement shall not be initiated by gravity when an automatic operator is disconnected.
- For pedestrian access in the vicinity of an automated vehicular gate, a separate pedestrian gate shall be provided. The pedestrian gate shall be installed in a location such that a pedestrian shall not come in contact with a moving vehicular access gate. A pedestrian gate shall not be incorporated into an automated vehicular gate panel.
- Any non-automated gate that is to be automated shall be upgraded to conform to the provisions of this specification.
- This specification shall not apply to gates generally used for pedestrian access and to vehicular gates not to be automated.
- Any existing automated gate, when the operator requires replacement, shall be upgraded to conform to the provisions of this specification in effect at that time.

The following provisions shall apply to Class I, Class II, Class III, and Class IV vehicular horizontal swing gates:

Gates shall be designed, constructed and installed so as not to create an entrapment area between the gate and the supporting structure or other fixed object when the gate moves toward the fully open position, subject to the following provisions.

The width of an object (such as a wall, pillar or column) covered by a swing gate when in the open position shall not exceed 4 inches (102 mm), measured from the centerline of the pivot point of the gate. Exception: For a gate that is not in compliance with this provision, the defined area shall be subject to the entrapment protection provisions of UL 325.

Except for the zone specified above the distance between a fixed object such as a wall, pillar or column, and a swing gate when in the open position shall not be less than 16 inches (406 mm). Exception: For a gate that is not in compliance with this provision, the defined area shall be subject to the entrapment protection provisions of UL 325.

SECONDARY ENTRAPMENT PROTECTION SENSORS

Most HySecurity gate operators are equipped with a Type A, Inherent Entrapment Sensor (IES). UL 325 Safety Standard compliance requires installation of external entrapment protection sensors, the number of which, depends on entrapment hazards that exist at each particular installation.

To comply with UL 325, the following external sensors may be used:

- Contact sensors, such as edge sensors
- Non-contact sensors, such as photo eyes

Site designer or installer can choose either photo eyes, edge sensors, or a combination of these devices. Whatever devices are used, protection in both opening and closing directions of gate travel must be provided.

UL 325 Safety Standard for automatic sliding gates specifically requires that edge sensors, photo eyes, or a combination of both devices be installed to protect against pedestrian entrapment in BOTH directions of gate travel and wherever entrapment hazards exist.

PHOTO EYES: One or more non-contact sensor (photo eyes) shall be located where entrapment risk or obstruction exists, such as perimeter reachable by a moving gate.

Care shall be exercised to reduce the risk of nuisance tripping, such as when a vehicle trips the sensor while the gate is moving.

SAFETY INFORMATION

EDGE SENSORS: One or more contact sensors (edge sensors) shall be located at leading edge, trailing edge, and post-mounted, both inside and outside of a sliding gate.

One or more contact sensors shall be located on the inside and outside leading edge of a swing gate. Additionally, if the bottom edge of a swing gate is greater than 6" (152mm) but less than 16" (406mm) above the ground at any point in its arc of travel, one or more contact sensors shall be located on the bottom edge.

SENSOR SECURITY: A hard-wired contact sensor shall be located and its wiring arranged so that communication between sensor and gate is not subjected to mechanical damage.

CAUTION

A contact or non-contact sensor is also required to protect against possible entrapment if gate opens to a position less than 16 inches from any object, such as a post or wall.

SENSOR FUNCTION and COMMUNICATION: A sensor that transmits its signal to gate operator must be located so its signal is not impeded by building structures or other obstructions. All sensors must be installed so that they function as intended for end-use conditions.

UL 325 LISTING: Edge sensors and photo eyes must be tested and labeled as "Recognized Components" or otherwise certified to UL 325 requirements in order to be deemed acceptable for use in a gate operator. Study Important Safety Instructions and consider your specific installation to determine where greatest entrapment risks exist. Locate edge sensors and/or photo sensors accordingly. Be certain that a sufficient number of sensors are used so that pedestrians are protected from entrapment in both directions of gate travel and all hazard areas are fully protected. Most HySecurity gate operators require external entrapment sensors that utilize Normally Closed (NC) contact means of monitoring. HySecurity gate operators utilizing the SmartCNX Controller require external entrapment sensors that have a 10k Ohm or 4-wire pulsed monitoring scheme. Refer to UL website at www.ul.com for most up-to-date list of gate operator safety standards (UL 325). Refer to www.astm.org for a complete list of ASTM F2200 Gate and Fence Standards.



Use of Approved External Entrapment Protection Sensors is **REQUIRED**

Gate operator will not automatically cycle the gate unless an indication that the appropriate number of external entrapment protection sensors are connected and operational.

The normally closed (NC) entrapment protection sensors wired to the Controller's SENSOR inputs are monitored using HySecurity software. Prompts appear on the display requesting specific configurations based on the gate operator type.

Effective August 1st, 2018, the UL 325 Standard has changed:

- The operator shall monitor for the presence of every device at least once during each open and close cycle (32.1.8)
- It shall not be possible to make simple modifications in the field by adding, suppressing or changing, either on the operator or external entrapment protection device(s), to bypass, interfere with, or otherwise defeat the monitoring function. (32.1.10)
- Entrapment zones are now defined for each gate type (4.23, 4.24, 4.29, 4.34)

SLIDE GATES: To enable fully automatic operation, all SLIDE gate operators will require a minimum of TWO monitored external entrapment protection sensors (one for each direction) to protect entrapment zones in both the open and close direction of travel.

Preferred solution for slide gates: A photo eye for the close direction and a hard-wired edge sensor for the open direction that is mounted to the face of the leading post of the fence behind the gate. (Reach through injuries are the most common hazard associated with automatic sliding gates)

SWING GATES: To enable fully automatic operation, all SWING gate operators will require a minimum of ONE monitored external entrapment protection sensor to protect entrapment zones in either the open or close direction of travel. However, an additional monitored sensor is required if there is a risk of entrapment in both directions of gate travel.

Preferred solution for swing gates: A photo eye for the close direction and/or a hard-wired wraparound edge sensor on the leading edge of the gate, which protects for both directions of gate travel.

For more information and latest updates, visit www.hysecurity.com/gatesafety

SAFETY INFORMATION

The following sensors have been tested with HySecurity gate operators by an independent laboratory and certified to comply with UL 325 7th Edition. Select sensors from this list for UL compliant gate automation solutions. Contact the sensor manufacturer for specific recommendations for use.



All external entrapment protection sensors must have NC sensor outputs and be wired to the SENSOR COM terminal for monitoring and powering purposes. Depending on software version, the sensor becomes powered when the gate operator's motor runs or is always powered when the operator is connected to AC power.

HySecurity Recommended Sensors				
	Mfg. Part #	Mfg.	Details	Hysecurity Part #
Photo Eyes (Retroreflective)	E3K-R10K4-NR	Omron	40 ft max range limit	MX000999
	NIR-50-325	EMX	45 ft max range limit	
	IRB-RET	EMX	53 ft max range limit	
	E-931-S50RRGQ	Seco-Larm	46 ft max range limit	
Photo Eyes (Thru-Beam)	IRB-MON*	EMX	65 ft max range limit	MX3990
	E-960-D90GQ	Seco-Larm	90 ft max range limit	
Edge Sensors	Sentir Series**	ASO Safety	Channel mount, high profile Channel mount, low profile Round, wraparound Square, wraparound	AS1502-0440-05 AS1502-0430-05 AS1501-0760 AS1501-0790
	CPT210-2U-#-T2	Miller Edge	10k resistor termination (replace # with length requirement in feet)	
Edge Sensor, Converters (10K to NC Contact)	Hy2NC	HySecurity	2-channel edge converter	MX4018
Edge, Wireless Kits	iGAZE RE Kit	Transmitter Solutions	50 ft line of sight max range limit	
	WEL-200 (kit with receiver and transmitter)	EMX	200 ft line of sight max range limit	
Multi-Input Module	The Solution – MIM-62	Miller Edge	6 inputs to 2 outputs	

*IRB-MON photo eyes are pre-bundled with HySecurity SwingSmart DC, SlideSmart DC and SlideDriver operators.

**Sentir Series ASO edge sensors are pre-bundled with HySecurity SlideSmart DC, SlideSmart CNX and SlideDriver operators.

Installers must assess each specific site and install sensors that protect all potential entrapment zones.

For more information visit Gate Safety at www.hysecurity.com/gatesafety or see latest operator manual at www.hysecurity.com/contact-us/technical-support/installation-manuals

Swing Gate Common Entrapment Zones

1. Leading Edge
2. Bottom Edge Entry / Exit
3. Posts
4. Post Pivot / Pinch Points
5. Arm Movement
6. Posts

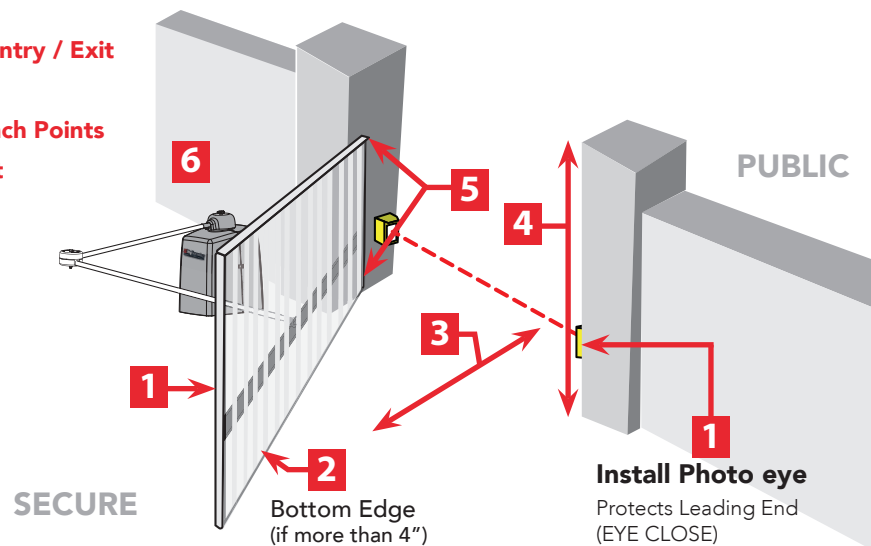

SAFETY INFORMATION

ELECTRICAL SAFETY

- Turn gate operator and all circuit breakers OFF before performing maintenance on the gate operator or making contact with output receptacles.
- Never insert any objects into output receptacles during operation. The possibility exists of electrical shock, electrocution, or death.
- Never let power wires lay in water.
- Never use damaged or worn wire when connecting equipment. Inspect for cuts in the insulation.
- Never grab or touch a live power cord or cable with wet hands. The possibility exists of electrical shock, electrocution or death.
- Always make certain that proper power has been selected for the job. See Cable Selection Chart in this manual.

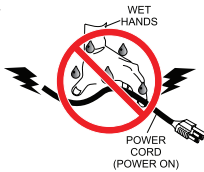

GROUNDING SAFETY

- Always make sure that electrical circuits are properly grounded to a suitable earth ground (ground rod) per the National Electrical Code (NEC) and local codes. Severe injury or death by electrocution can result from operating an ungrounded operator.
- Never use gas piping as an electrical ground.



BATTERY SAFETY

HySecurity operators use sealed Absorbed Glass Mat (AGM) batteries and HySecurity highly recommends replacing used batteries with new AGM-type batteries.

CAUTION

Batteries used with HySecurity gate operator contain materials considered hazardous to environment. Proper battery disposal is required by federal law. Refer to *Hazardous Waste Regulations* federal guidelines.

To reduce risk of fire or injury to persons:

- Observe polarity between batteries and charging circuit.
- Never mix battery sizes, types, or brands. Charging circuit on HySecurity DC operators is designed for AGM-type batteries, not flooded lead acid-type batteries.
- Exercise care in handling batteries. Be aware metal found in rings, bracelets, and keys can conduct electricity, short batteries, and cause potential injury.
- Do not open or mutilate batteries. Battery cells contain corrosive materials which may cause burns and other injuries. Material within batteries is toxic.
- Always dispose of batteries properly. Do not place batteries in fire. Battery cells may explode. Follow federal guidelines for proper disposal of hazardous waste.
- Always keep battery cables in good working condition. Repair or replace all worn cables.
- Replace batteries according to instructions found in *DC Battery Replacement*.
- Do not charge frozen battery. Battery can explode. If frozen, warm the battery to at least 61°F (16°C).



ENVIRONMENTAL SAFETY/ HAZARDOUS MATERIALS AND PROPER DISPOSAL

Decommissioning is a controlled process used to safely retire a piece of equipment that is no longer serviceable. If the equipment poses an unacceptable and unreparable safety risk due to wear or damage or is no longer cost effective to maintain (beyond life-cycle reliability) and is to be decommissioned (demolition and dismantlement), be sure to follow rules below.



- Do not pour waste or oil directly onto the ground, down a drain or into any water source.
- Contact your country's Department of Public Works or recycling agency in your area and arrange for proper disposal of any electrical components, waste or oil associated with this equipment.
- When the life cycle of this equipment is over, remove battery and bring to appropriate facility for lead reclamation. Use safety precautions when handling batteries that contain sulfuric acid.
- When the life cycle of this equipment is over, it is recommended that the frame and all other metal and plastic parts be sent to a recycling center.

Metal and plastic recycling involves the collection of metal and plastic from discarded products and its transformation into raw materials to use in manufacturing a new product.

SAFETY INFORMATION

Recyclers and manufacturers alike promote the process of recycling metal and plastic. Using a metal and plastic recycling center promotes energy cost savings.

WIND LOAD FACTORS & SITE PREP

Wind load is always a factor when considering the appropriate gate for a particular site. Solid gate panels produce a larger wind load than gates with slats or open decorative features. If you are installing a gate operator in a high wind area, gate design will affect the load on the gate operator because wind load acts the same as an obstruction. Good gate panel design presents a low surface area to reduce the wind load.

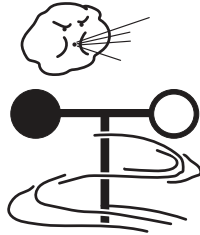

If gate is heavy and near weight capacity of what the gate operator can handle (see specifications), make sure it has an open design that allows wind to flow through it. A solid or semi-solid gate design under certain wind load conditions may cause damage to gate operator and is not covered by the HySecurity Limited Warranty.

Several factors play into calculations of wind load on a gate panel. To find out maximum wind speed in areas around the United States, search for US government wind speed maps on the internet. If you don't know how to calculate for wind load, ask a mechanical engineer or site architect for assistance prior to installing gate operator and gate panels.

When the IES trips, it sends a signal to gate operator to stop and reverse direction. This feature may be falsely triggered in excessively windy conditions because wind itself, acting over surface area of gate panel, can provide necessary force to trigger IES.

CAUTION

Do not adjust IES sensitivity to accommodate for inappropriately designed gate panels. Loss of IES sensitivity increases mechanical wear on gate hardware and gate operator. It may also pose a safety hazard. Compensating for wind loads by adjusting IES may set IES sensitivity to a level which, when encountering an obstruction, ignores obstruction and fails to reverse direction. For more information, refer to Adjusting the IES Sensitivity.

MAINTENANCE OF GATE SYSTEMS

To keep your automated gate system performing both safely and reliably it is important to ensure that the components of that system are functioning properly.

At least monthly:

- Disconnect the gate operator and manually move the gate through its range of travel. Note any squeaks from rollers or hinges or areas of binding. The gate should travel smoothly and quietly throughout its range. If it does not, contact a gate professional to correct the problem.
- Reconnect the gate operator and perform the following tests:
 - With the gate opening, block any photo eyes and/or depress any safety edges used to protect the open direction. The gate should stop and/or reverse.
 - With the gate closing, block any photo eyes and/or depress any safety edges used to protect the close direction. The gate should stop and/or reverse.
 - Using a suitable obstruction in the path of the gate (a solid, immovable object), run the gate in the open direction until it contacts the obstruction. The gate should stop and reverse.
 - Using a suitable obstruction in the path of the gate (a solid, immovable object), run the gate in the close direction until it contacts the obstruction. The gate should stop and reverse.

INSTALLATION PREPARATION AND PROCESS OVERVIEW

INSTALLATION PREPARATION CHECKLIST

1. Read all of the instructions, especially the Important Information at the beginning of this manual, before you attempt installation. This section is focused upon mechanical installation. For electrical setup, skip to the section on system configuration and use of the Smart Touch Controller.
2. Check to see that the mounting slab is the right size and ready to have an operator attached. Also check that electrical conduits are correctly located to enter the operator base. Hy-Security recommends the footing size of the HVG posts be determined by an engineer. Minimum footings are 3' X 3' X 6' deep or below the local frost line, whichever is greater.

INSTALLATION PROCESS OVERVIEW

- Mount the control box and connect all conduit fittings.
- Mount the operator post.
- Install all accessories such as: vehicle sensing loops, access control devices, gate edge sensors or photo eyes.
- Pull all wires and hoses into conduits.
- Test the basic operator functions.
- Mount the gate panel and make fine adjustments.

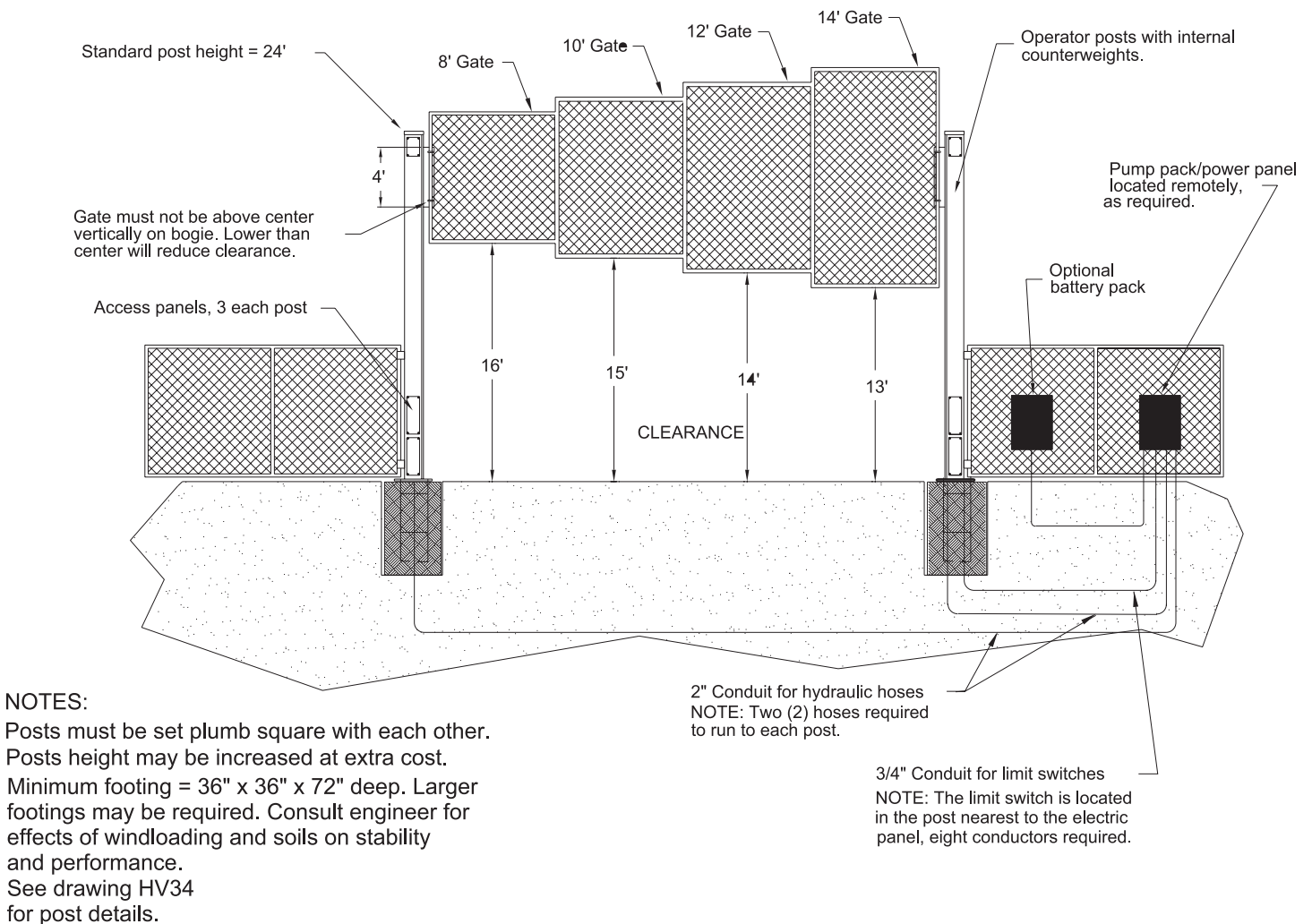
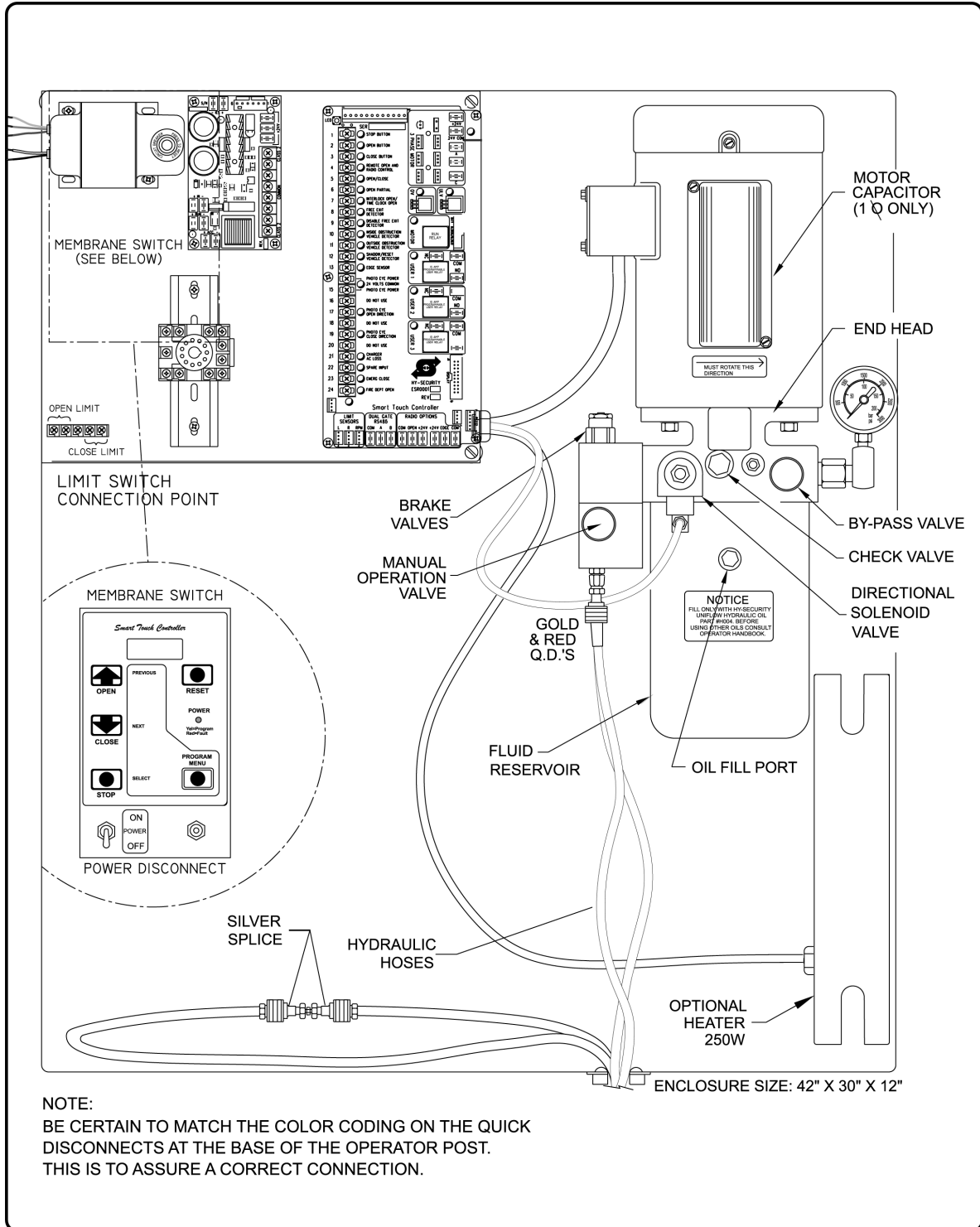

Figure 2. Installation Process Overview

HVG PUMP AND ELECTRICAL PANEL

HVG Pump and Electrical Panel



 seattle, washington	TITLE	DRAWN	DATE	THIRD ANGLE PROJECTION		REV
	HVG TYPICAL PUMP AND ELECTRICAL PANEL	D. B.	05/09/00			B
		CHECKED	DATE	ERN NUMBER	DATE	
		APPROVED	DATE	DRAWING NUMBER: HV17 ST		SHT OF 1

Figure 3. HVG Pump and Electrical Panel

HVG 420 POST PLAN AND DIMENSIONS

HVG 420 Post Plan and Dimensions

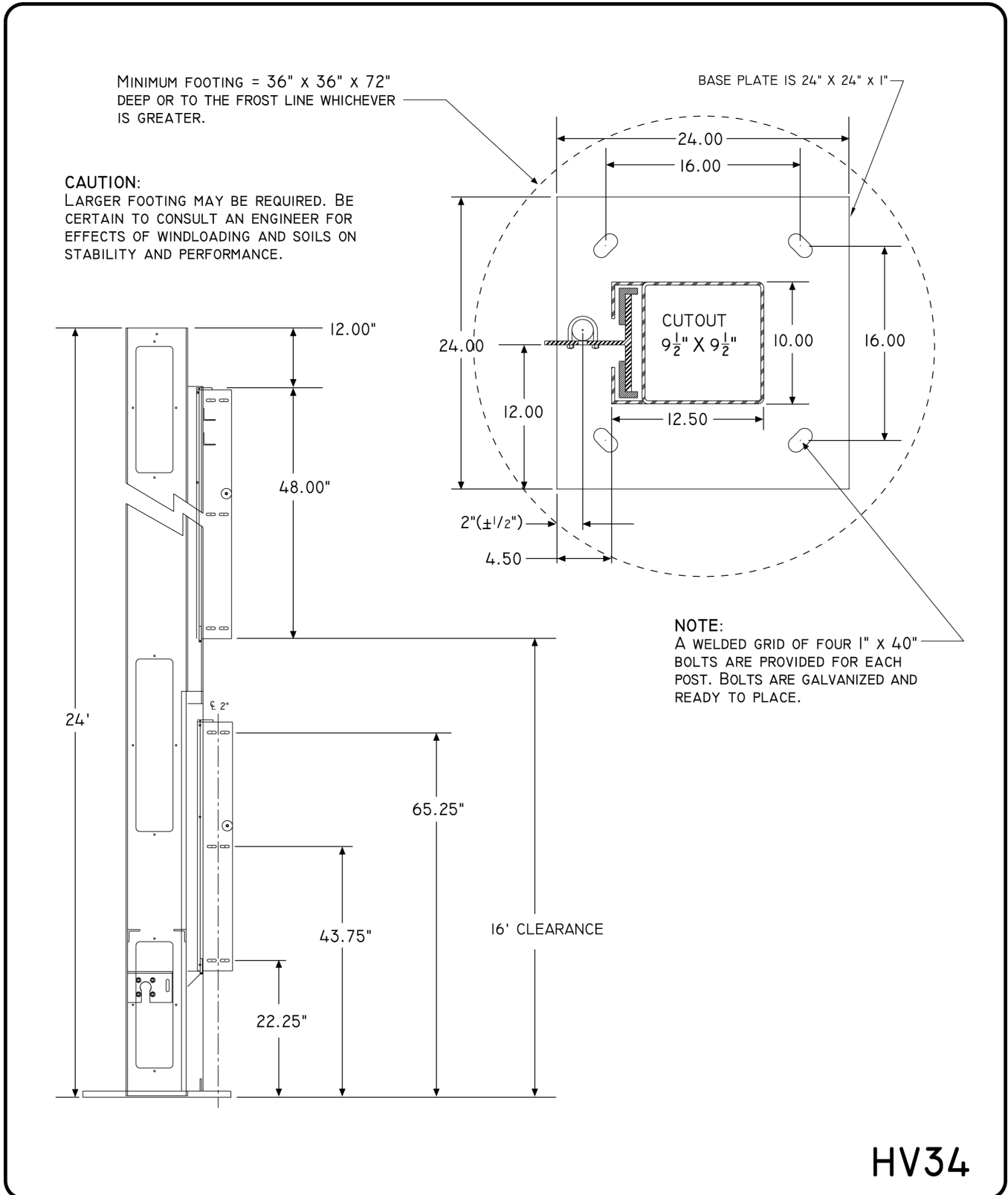

Figure 4. HVG 420 Post Plan and Dimensions

HVG 460 POST PLAN AND DIMENSIONS

HVG 460 Post Plan and Dimensions

MINIMUM FOOTING = 36" x 36" x 72"
DEEP OR TO THE FROST LINE WHICHEVER
IS GREATER.

CAUTION:
LARGER FOOTING MAY BE REQUIRED. BE
CERTAIN TO CONSULT AN ENGINEER FOR
EFFECTS OF WINDLOADING AND SOILS ON
STABILITY AND PERFORMANCE.

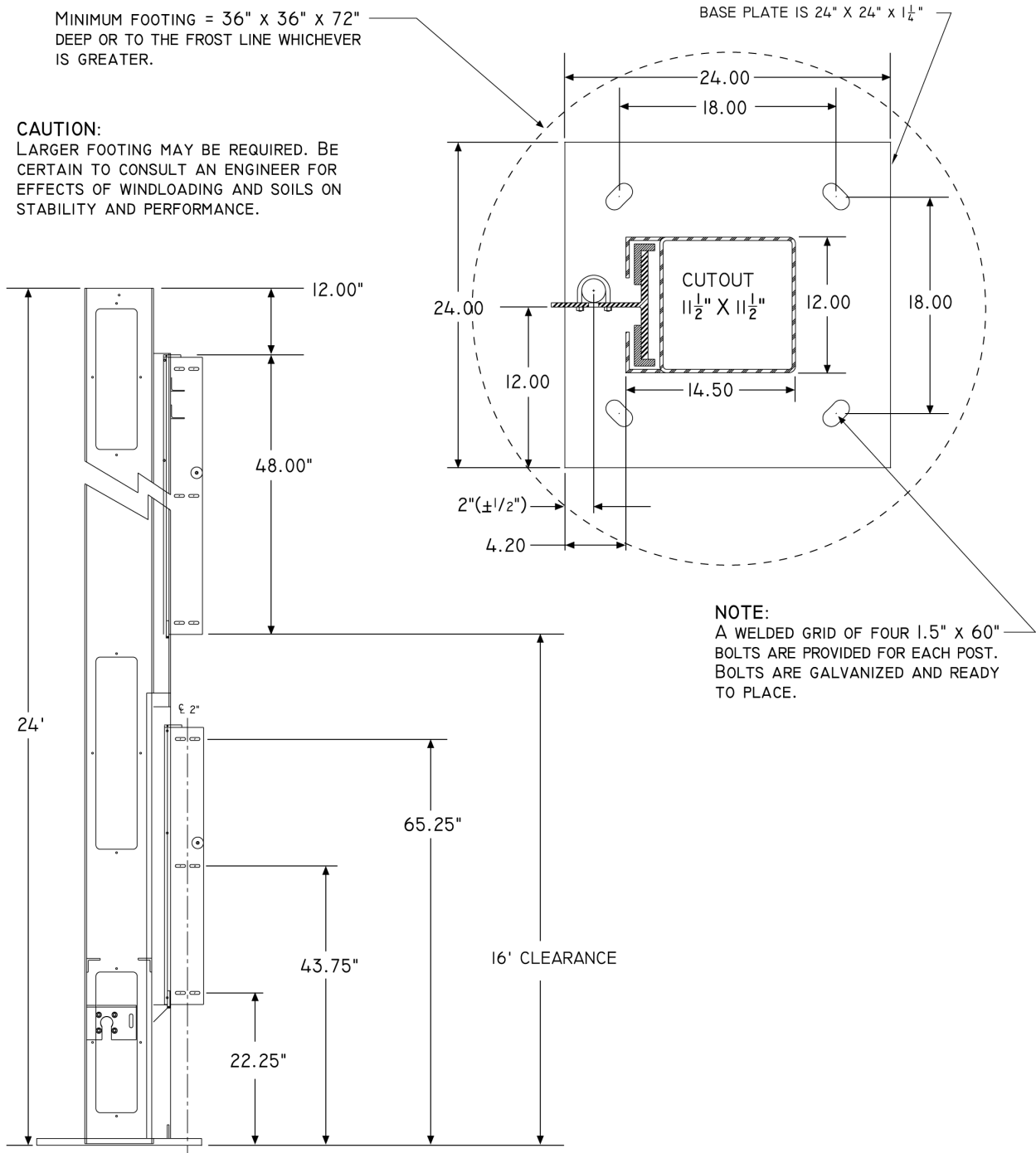

NOTE:
A WELDED GRID OF FOUR 1.5" X 60"
BOLTS ARE PROVIDED FOR EACH POST.
BOLTS ARE GALVANIZED AND READY
TO PLACE.

HV36

Figure 5. HVG 460 Post Plan and Dimensions

FIELD HOSE MEASUREMENTS FOR HVG OPERATORS

NOTICE

HVG operators are usually shipped without the hoses needed to complete the system. Hy-Security will make these hoses in custom lengths as required, attach the quick disconnect fittings and pre-charge the hoses with hydraulic fluid. The use of pre-charged hoses is important to avoid the introduction of air into the system.

When field measuring for the necessary hose length to order, the following may be helpful:

1. There is very little room in the base of the HVG operator post and limited room in the control/power panel, therefore, your field measurements must be very accurate when calculating the length of the necessary hydraulic hoses. If your dimensions are too short, you will not reach the connections, if your measurements are too long, you will have trouble finding space for the excess hose.

2. Remember that two hoses are needed for each post. This means that you need four hoses.
3. Be sure to measure accurately the following distances: (the best way is to pull a cord through the conduit, mark it, and then measure it.)
 - a. The bottom of the pump/control panel to the bottom of the trench, plus 24"
 - b. The total distance across the trench.
 - c. The distance back up to the bottom of the operator, plus 6"
4. The part number for the 3/8" HVG hose is HSFHO 006 4216. Up to 100' of hose is included in the price of the HVG operator; any additional length needed is sold by the lineal foot.

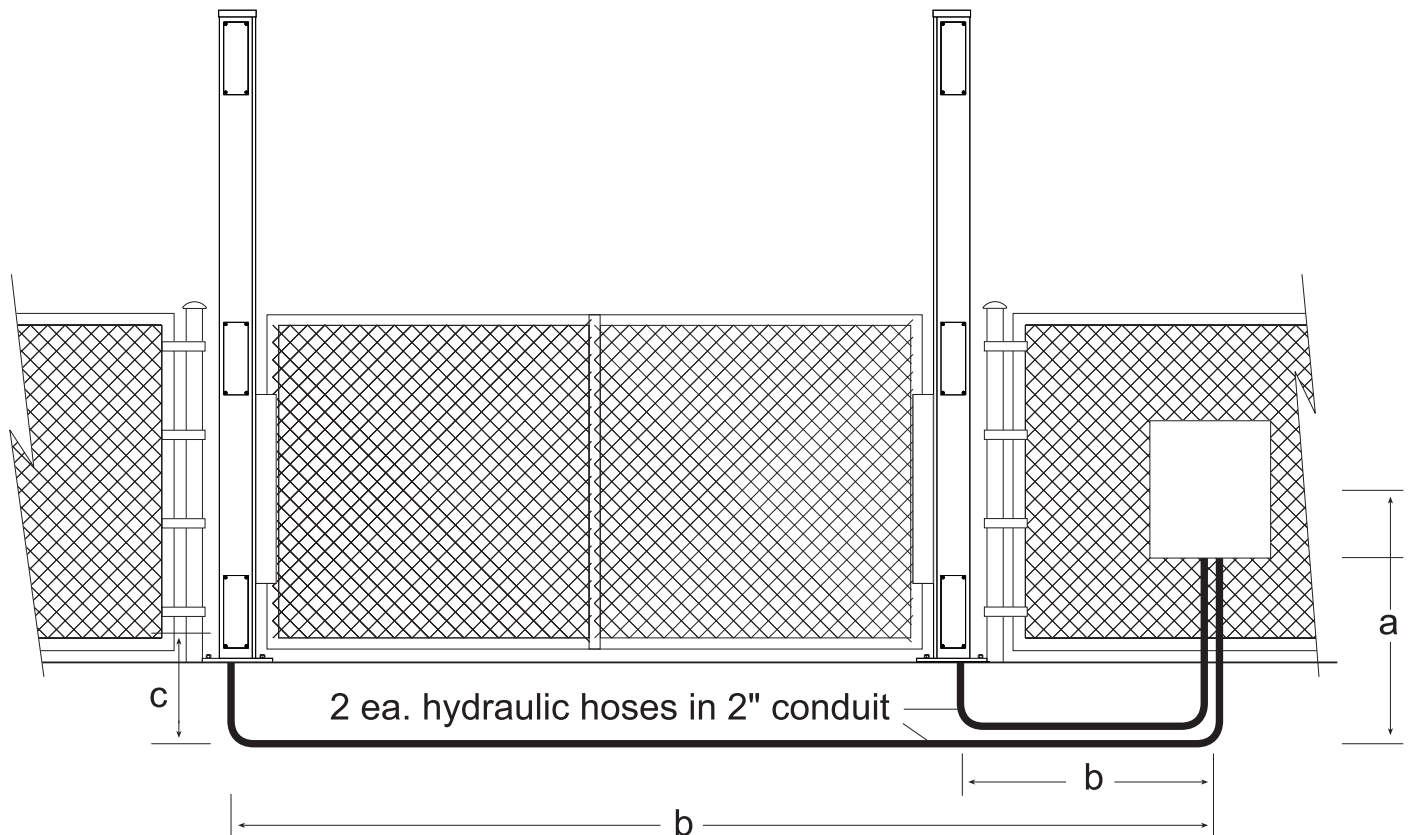

Figure 6. Installation Process Overview

1. Mount control box and connect all conduit fittings.
 - a. Mount control enclosure within 20' of the nearest operator post. If installing the DC operator version, mount the battery power supply box very near the controller enclosure because of the high current demand by DC motor – For more information, see the Two Part Operator section.
 - b. Attach all electrical conduits as required, note diagram below and see step number 3.
2. Typical conduits required at the control enclosure
 - a. High voltage wires: 208 or 230 single phase or 208, 230 or 480 three phase
 - b. 2" conduit to each vertical lift post for the hydraulic hoses.
 - c. 3/4" conduit to the post with the rotary limit switch.
 - d. Access control wires (Keypads, telephone entry systems or any access control devices)
 - e. Loop wires for vehicle detectors
 - f. Other accessories such as warning lights etc.
3. Set the Vertical Lift posts
 - a. Verify that the concrete footings have cured adequately.
 - b. Clean threads of the mounting bolts with a wire brush to remove any concrete residue.
 - c. Screw a nut onto each threaded stud and turn down until there are only two or three threads remain. Lay a heavy washer on top of each nut and verify that there is about 3" of thread remaining.
 - d. Mount the vertical lift posts onto the foundation. Be certain that the removable access covers face into the secured side of the opening. The posts must be square with each other across the opening
 - e. Place another heavy washer and nut onto each threaded stud and secure loosely. verify posts are square with respect to each other and perfectly level and plumb before final tightening. Use a plumb bob or a level that is at least six foot long to verify. Use lower mounting nuts as adjusters to achieve "plumb" in both directions and twist the posts as needed to achieve "square" to the opposite post.
4. Pull and connect all necessary electrical wires and hydraulic hoses
 - a. HVG operators normally do not ship with hydraulic hoses included, until installer specifies exact length. See page 19 and verify correct length before ordering.
 - b. For protection, tape hydraulic hose(s) ends and pull through the 2" conduit from each post to controller enclosure. Connect hoses to their respective couplings, being certain to match color coded ends as described on page 24. Be certain connectors are firmly snapped together.
 - c. Connect electrical power wiring to On/Off switch loose wires and a grounding wire to electrical panel lower left corner. Be certain to the labeled voltage and phase of the operator matches the available supply. Also be certain to oversize the branch circuit wires to allow for voltage drop, especially for single-phase machines. See the wire size schedules in the appendix, page 72.
 - d. Verify primary tap of control transformer is connected to match supplied voltage. It is especially important to distinguish between 208 and 230 Volt supplies. The various voltage taps are identified by a label on the transformer.
 - e. Pull a minimum of four 18 gage wires, for the limit switches from control panel to junction area in the base of the operator post with the rotary limit switch. Connect to the rotary limit switch as shown on page 23. Connect these wires to the control enclosure at the five pole terminal

5. Test and Adjust the Operator (See Smart Touch Setup First to Enable the Controls)
 - a. Remove the blue plastic shipping plug on the pump and replace it with the black vent cap that is provided.
 - b. Remove the cap screw on the release sprocket driven by the hydraulic motor in the bottom of each vertical lift post. This will allow the motors to rotate freely for basic testing.
 - c. Test basic functions of the operator first, before connecting any external control wiring. If your operator is equipped with vehicle detectors, be certain that they are connected to a loop or unplugged so that they do not cause interference with the function of the machine.
 - d. If the electric motor runs but the hydraulic motors in each post do not, close the bypass valve located on the pump, near the base of the electric motor, or reverse any two poles of a threephase motor. Also be certain that the hose quick connectors are firmly engaged.
6. Mount the gate panel to the posts
 - a. Place the gate panel into the opening from the outside side of the property so that the fasteners all face the secure side of the gate. Before mounting, verify that the width of the gate panel, from C/L to C/L of the end verticals, is equal to the dimension between the angle guides for the bogies, less 4-3/4" on the HVG 420 or 5-1/2" on the HVG 460. If the gate panel is too wide it will bind and interfere with the smooth operation of the gate operator and may actually cause damage to the top covers of the vertical lift posts.
 - b. The cap screws on the release sprocket in the bottom of each post must be removed. The bogies must be free for adjustment so that they may be centered on the gate panel's vertical edges. Mount the gate panel to the bogies while being sure that no tension is applied that may cause a binding action during travel. Replace the cap screws in the sprockets. Be sure that they penetrate through the hole in the sprocket and that the heads are fully seated.
 - c. Install the 1/8" auto level cables using the supplied cable. Slip the ends with the loops into the upper eyebolts. Run cables under the sheaves, across the face of the gate panel, over the opposite sheaves and to the bottom eyebolts. Pull snug and secure with clamps, then tension by adjusting the lower eyebolts. The cables should not hang loose, but the compression spring at the upper eyebolt should not be collapsed either. Cut off excess cable.

7. Install the required counterweights
 - a. Remove the middle access cover located 4' above the ground and fully open the gate. *(See note at end of section) Load the counter weights into the weight cage, which should now be visible through the access area. The counter weight for each post should be equal to one half of the total weight of the entire gate panel. Sheared steel plate makes an easy to handle counterweight material. For the HVG 420, use 7" x 7" x 3/4" plate, which weighs about 10.4 pounds each. For the HVG 460, use 10" x 10" x 1/2" material, which weighs about 14 pounds each. Sheared Universal Mill plate is easy to obtain at any steel supplier. The exact amount of weight to achieve balance is easily determined when the pressure to open and close the gate is identical. Adding extra counterweight so that the open pressure is about 200 PSI less than the close pressure, may be a good idea to make an easy manual operation.
 - b. Operate the system a few times to verify that everything is working properly. Set the open and close limit stop positions as required. Set the brake valves. After testing the basic functions, add accessories and external control wiring. Fully test the operator functions again.

NOTICE

Since there is no counter balance for the initial operation, it may be necessary to assist the gate in opening. If necessary, use a forklift, block and tackle or manpower for this operation. If the hydraulic pump runs and the gate does not move during this operation, no harm is done. However be necessary to shunt the inherent sensor input with a jumper wire for this initial setup.

LIMIT SWITCH SETTING/WIRING

1. For all HVG operators, four conductors minimum are required from the limit switch to the control panel.
2. Connect a pair of wires from the normally closed A side of each switch to the terminal strip in the control box marked for the limit connections. The normally open B side of the switch is unused unless the customer requires a special function.

3. The limit switch is pre-set at the factory, to limit full travel in both directions. Fine tuning may be required in the field, to suit conditions.
4. To adjust the limits:
 - a. Loosen the cam clamp screws.
 - b. Depress the pinion gear, near the switch, engaging the gear teeth.
 - c. Rotate the cam to trip the limit switch, several inches before full gate travel, to allow the gate to decelerate.
 - d. Tighten clamp screws.
 - e. Repeat steps "a" and "d", for each limit switch.

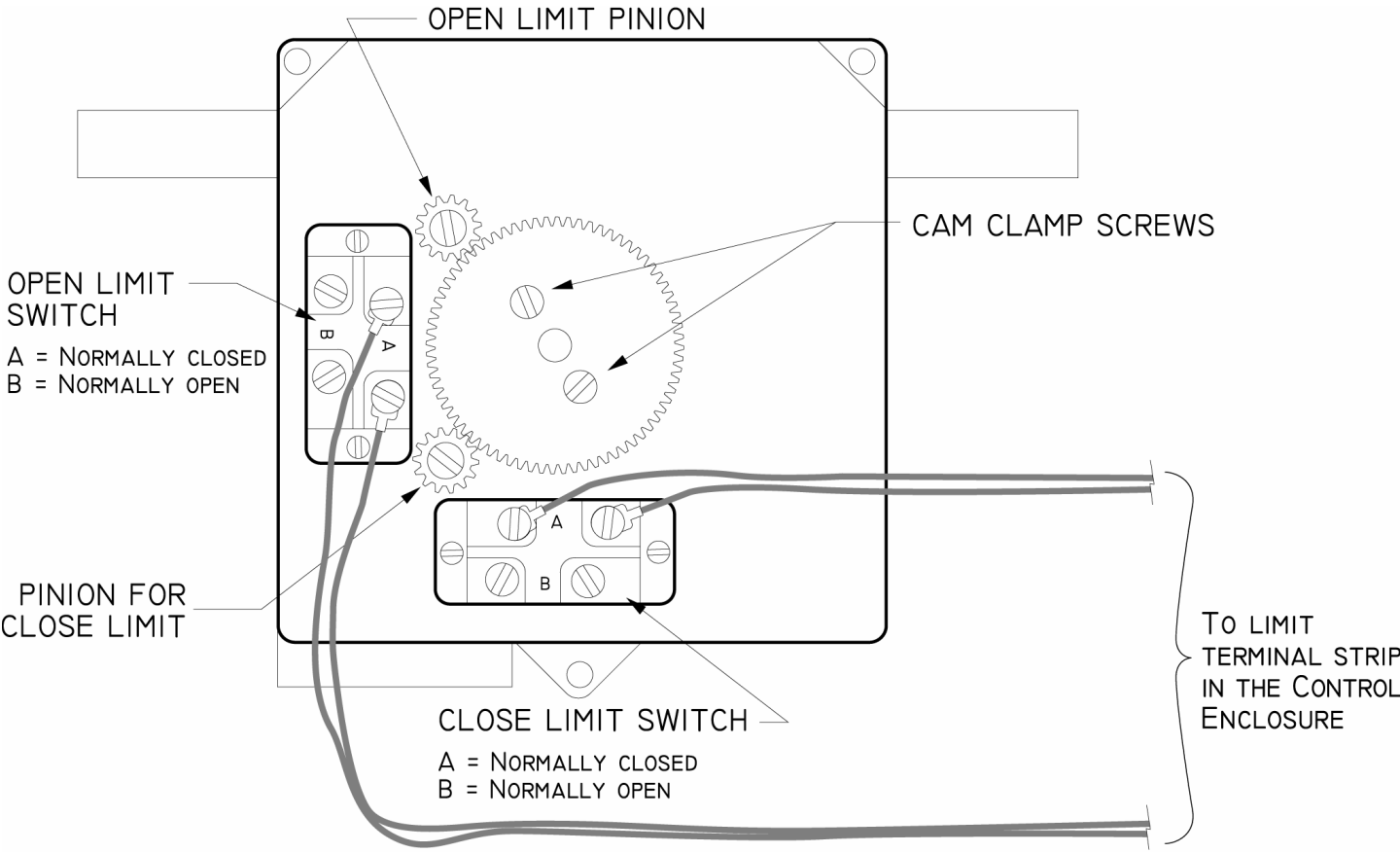

Figure 7. Limit Switch Setting/Wiring

HOSE CONNECTIONS

1. Pull short hoses through the conduit into bottom of nearest HVG post, make certain that the gold and red ends will be at the post, and the red and silver ends will be at pump enclosure.

- 2. Pull longest hoses through the conduit into bottom of farthest HVG post, make certain that the gold and red ends at the post, and the gold and silver ends at pump enclosure.
- 3. At posts, mate red plugs to red sockets and gold to gold. At pump enclosure, mate in the same manner matching colors. Plug gold into gold and red to red onto the pump and splice the two silver ends together with the connector that is supplied.

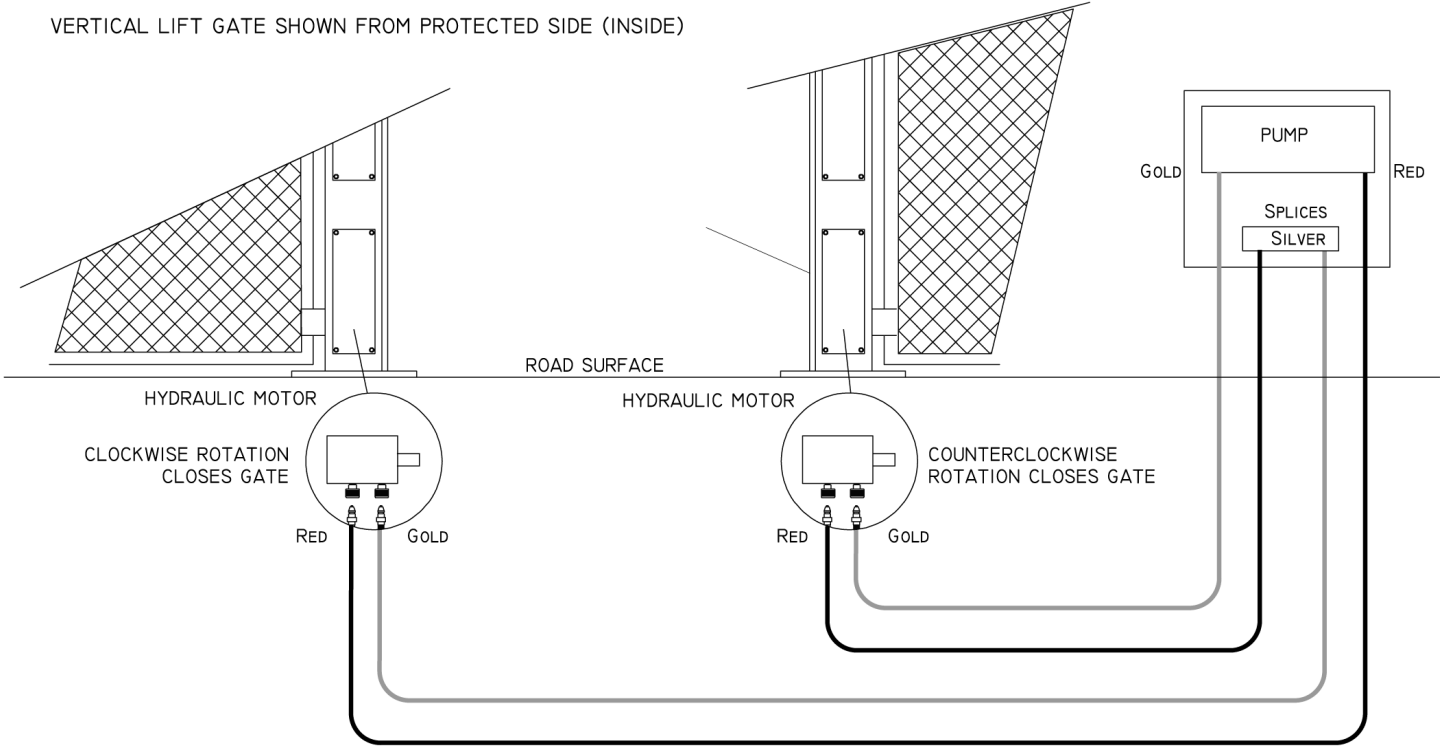

Figure 8. Hose Connection Diagram

MANUAL OPERATION

To manually lift the gate in the event of a power failure, you must pull and twist the hydraulic bypass valve that is located on the hydraulic pump right where the hoses connect. This will allow the hydraulic motors in each post to unlock so the gate panel can now be manually lifted.

Depending upon how well the gate was counterweighted, the gate may be easy to lift or fairly difficult. Review the counter weight installation instructions on page 22. In some scenarios, a forklift may be required to lift the gate until sufficient counterweight has been installed.

An alternate means of unlocking the system for manual operation that allows easier lifting of the gate can be accomplished by removing the socked head screws from the special release sprockets on each hydraulic motor. To access the release sprockets, remove the lowest access covers on each post and use an Allen wrench to remove the screws in the face of the sprocket at the end of the motor shaft.

Tie a rope onto the bottom of the gate to make it easy to pull downward.

MECHANICAL AND HYDRAULIC ADJUSTMENTS

1. Brake Valves

Proper adjustment of the brake valves is important for smooth operation of the gate. In order for the brake valves to have time to function, the limit switch must trigger at least nine inches before the point at which you want the gate to stop. Adjustment of the brake valves, one for each direction of travel, will determine how quickly the gate actually stops. If adjustment is needed, loosen the 9/16" lock nut on the top of the brake valve and turn the adjustment stem, in about ¼ turn increments, with an Allen wrench. The adjustment works opposite of typical, such that a counter-clockwise adjustment will stop the gate more rapidly. If the adjustment is set too loose, the gate will bang into its physical stops. If the adjustment is set too tight, the system pressure will increase, the gate speed may decrease and the gate will jerk to a stop. Set the brake valve to achieve a controlled smooth stop, and then retighten the locking nut to hold the setting.

2. Pressure Relief Valve

This valve, which governs the maximum system hydraulic pressure available, is located on the backside of the pump, just above the limit switch. Installers are encouraged to reduce the relief valve setting to the lowest pressure that will reliably operate the gate. A lower setting reduces the maximum force that the gate operator can exert and saves energy. If adjustment is needed, loosen the 9/16" lock nut and turn the adjustment stem with a wrench. Lower pressure (force) is achieved by turning the adjuster stem counter-clockwise. The only way to display the actual relief valve setting is to unplug the hydraulic hoses from the quick disconnect fittings. Be certain to retighten the locking nut to hold the desired setting and reconnect the hoses correctly. Also see the drawing on page 66 for the location and a schedule of factory pressure relief settings.

3. Directional Valve

This valve is solenoid activated. The directional valve is below the motor near the front of the pump and energizes in order to direct the hydraulic flow to open the gate. No adjustment of this valve is possible or ever needed.

4. Chain Tension

Proper tensioning of the chain is required upon installation and periodically as a maintenance item. There must be some tension so that the chain does not sag, which would likely cause it to skip on the drive sprocket, which would alter the limit switch setting. The chain must not however be over tensioned, which would lead to stretching and possible failure. Chain tension adjustment is made at the threaded rod attachment at the bottom of the weight cage, which is accessible when the gate is fully open.

5. Auto Level Cable Tension

The 1/8" auto level cables keep the gate from "keystoning" throughout its travel. The cable tension must always be light or the cable will fray. A threaded eye bolt adjuster is provided at the bottom of each post and a spring at the top of the post is provided to assure constant tension. Adjust the cable tension for each side so that the gate is visibly level when viewed from a distance. When complete the springs at the top of the post must only be slightly compressed. STC Basics

SMART TOUCH CONTROLLER

Read this page if you are unfamiliar with using the Smart Touch Controller.

You must learn to navigate and change menu settings within the Smart Touch Controller before an installation can be completed or any control settings or function changes can be made.

Until a new operator has been configured, the controls are not functional and the display is locked in the menu mode until the User Class 1-4, has been selected. See the next page for instructions on how to make this setting.

1. There are five buttons on the membrane switch pad that provide control of everything. The Open, Close and Stop buttons serve as a three-button control station, but in the Menu Mode, they become Previous, Next and Select buttons. The Program Menu button is used to both enter and exit the Menu Mode. The Reset button clears all Errors or Faults that may occur and returns the control to its normal functioning state.
2. When in a Menu Mode, changes to be made to a Menu setting are accomplished by pressing the Previous, Next and Select buttons in the following sequence:
 - a. Press the Next button to move forward through the list of menu items that are available, as shown on page 32 - page 35, or press the Previous button to move back to an item that you recently passed.
 - b. Press the Select button if you wish to make a setting change to a menu item. The menu item will flash to indicate that its setting is ready to be changed.
 - c. Press Next to move forward or Previous to go back to an earlier setting choice.
 - d. When you have located the setting that you want to use, press the Select button and the program will accept the change and stop blinking.
 - e. The Program Menu button does not allow an exit to Run Mode while a selection is still blinking. Press the Select button to stop the blinking, then you may exit to Run Mode.
3. Once configured, the operator will be in the Run Mode. From the Run Mode, to gain access to the User Menu or the Installer Menu, follow these steps:
 - a. Note that the Program Menu button will not function unless the gate is at rest and no open or close inputs are active. Verify system status by pressing the LED button to disclose any active inputs. There must not be any Alerts, Faults or Errors. Press the Reset button to clear the system if necessary.
 - b. Press the Program Menu button and watch the LCD scroll the system data, or press the Program Menu key a 2nd time to skip the scroll. The scrolled data displays the information in the table on page 32.
 - c. The LCD display scroll will stop at the menu item for the auto close timer setting [Ct ____]. This is the first item in the User Menu.
 - d. To access the more detailed Installer Menu, the system must first be in the User Menu, and then simultaneously press the Reset button and the Open button. The LCD will change to display the UL usage class menu item [uC ____] This is the first item in the Installer Menu.
4. Pressing the Program Menu button when the User or Installer Menu is not blinking will return the system to the Run Mode.

STC INSTALLATION CONFIGURATION

1. The hydraulic hoses must be connected to the quick couplers by matching the color coded ends to configure the correct directional control of the gate. If the hoses are connected incorrectly, the gate will run backwards (close when open button is activated) and this may trigger an error [Err 1] on the LCD display. (The Reset button must be pushed if this happens).
2. Turn on the power switch and observe that the LCD will first show the software version, and then stop at a steady display within two seconds. If the display reads [uC 0] go to step 3. If the operator has previously been configured, the Installer Menu must be accessed in order to reach the system configuration menu items: see step 3d at the top of this page.
3. When turning on the power for a new machine, the LCD display directly enters the Installer Menu at the [uC __] menu item, which is for selecting the user class as defined by UL. Select [uC 1] - [uC 2] - [uC 3] or [uC 4] depending upon the use application.
4. Once the usage class is set, you should exit the Installer Menu, by pressing the Program Menu button. The LCD display jumps to the close timer [Ct__] setting in the User menu, which may now be set. Either press the Program Menu button again to exit to normal run mode or set the close timer by the same programming sequence described at the previous page.
5. Note that the Installer menu cannot be exited by any means until the selection for the UL usage class [uC __] has been entered.

Test for normal function of the gate operator by running it both open and closed from the pushbuttons on the membrane switch pad. It is best to verify normal function before the gate panel has been mounted.

SMART TOUCH CONTROLLER

STC WIRING CONTROL INPUTS

1. Test the basic open and close operator function before wiring the external control inputs. This makes it easier to troubleshoot if an unexpected function issue arises.
2. Each input has an LED to indicate when that input is active. To disclose the input status, the LED tact button must be pushed. This button is in corner near the Stop input.
3. All the control device inputs listed below are shown as a single wire input because the other wire is connected the Common Terminal Buss on the Power Supply board. The Emergency Close and Fire Dept. Open inputs are an exception and require a +24 Volt input in order to be activated. The +24 is available at the spade terminals next to the Common Buss.

SMART TOUCH CONTROLLER INPUTS

1. *Stop Push button (N.C. input, jumper to Common if unused)
2. *Open Push Button (not for radio or remote access controls)
3. *Close Push button (not for radio or remote access controls)
4. Remote Open & Radio Control (For radio / remote open device - menu opt. to also close the gate, but only when fully open)
5. Open/Close button (pushbutton or radio controls)
6. Partial Open (this input disabled on vertical lift gates)
7. Open interlock input or Time clock Open (menu configurable)
8. Free Exit vehicle detector
9. Disable Free Exit vehicle detector
10. Inside Obstruction vehicle detector (Inside reversing loop)
11. Outside Obstruction vehicle detector (Outside reversing loop)

12. Shadow vehicle detector (Shadow is for Swing gates only)
13. Edge Sensor (from sensing edge on the bottom of the gate)
14. Photo eye Common Power (supply for PE power & PE Com)
15. Photo eye Common Power (supply for PE power & PE Com)
16. Not available (N/A)
17. Photo eye Open direction (not used in HVG Vertical Lift Operators)
18. Not available (N/A)
19. Photo eye Close direction (beam spans the roadway)
20. Not available (N/A)
21. Charger AC power loss (only used in battery type operators)
22. Spare Input (unused – may have function in custom applications)
23. *Emergency Close (must menu enable and input +24 Volts to trigger) Overrides photo eyes, gate edge & vehicle detectors.
24. *Fire Dept. Open (must menu enable and input +24 Volts to trigger) Overrides photo eyes & gate edge.

WARNING

* Do not connect an external control to terminals #1, 2 or 3, unless the controls are located such that there is a clear view of the entire gate area. For controls not within sight, use input terminals #4, 5 or 7.

WARNING

*The Emergency Close and Fire Dept. Open inputs are to be used only if access to these controls are guarded in sufficient manner such that there is always supervision when activated.

SMART TOUCH CONTROLLER

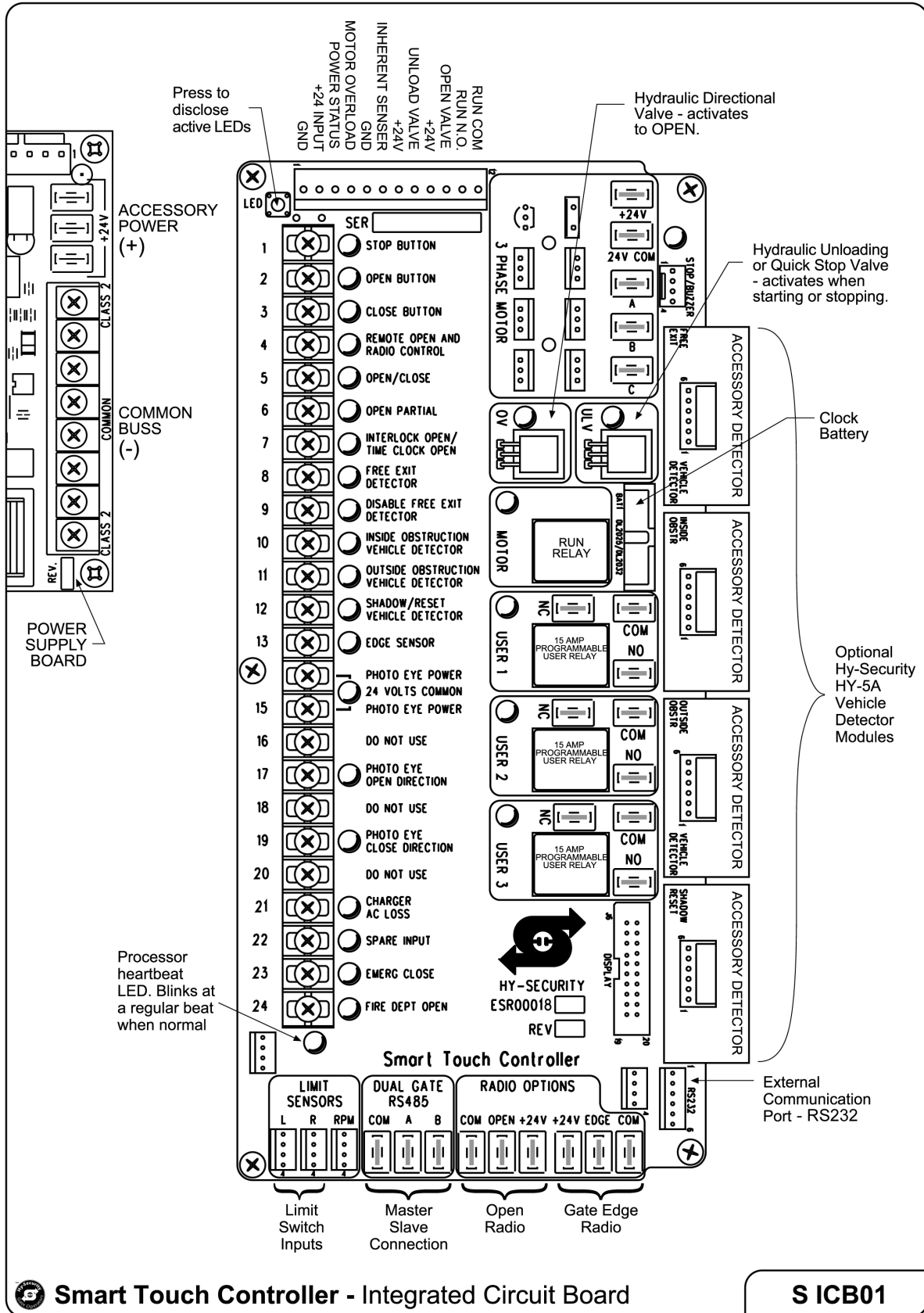

Figure 9. STC Integrated Circuit Board Connecting a Primary/Secondary Pair

If you are installing two HVG gates to operate as a Primary/Slave pair, the process is very simple. There is no need to order a special model or any adapters. The area of the board marked Dual Gate employs a 3-wire RS485 serial port for communication between Primary & Secondary operators.

1. An electrical conduit for the interconnecting wires must span between the two operators.
2. Complete the installation of both of the HVG gate operators as separate machines and verify that their basic functions are correct as solo operators before interconnecting them.
3. The two gate operators should be supplied by home runs from separate 20 Ampere circuit breakers in the main panel, but if there is only one circuit, be absolutely certain that the breaker and wire size is sufficient for the load of two motors. See the wire size schedules on page 72.
4. External control inputs, vehicle detectors and entrapment protection sensors may be connected to either gate operator without regard to preference.
5. Dual Gate wiring requires 3 wires. HySecurity recommends using a 2-pair, twisted, shielded cable with one pair of wires used to connect A-A and B-B terminals between the two boards. The other pair will connect the Common terminals. To interconnect the two operators, route a shielded twisted pair with an internal ground wire between the electric control boxes and connect to the RS485 Dual Gate terminals, in matching order on both machines: In the RS 485 shaded area connect the terminals for Primary Com to Secondary Com with the ground shield trace wire, and connect the Primary A to Secondary A and the Primary B to Secondary B using the insulated twisted pair of wires.
6. The Installer Menu in each machine must be set as a Primary or a Secondary under menu item [dg_]. Set one operator as a Secondary [dg_1] and the other as a Primary [dg_2]. If the function of any external input is to be different than the factory default, configure for the desired function on the operator where that input is connected. Internal functions, such as the close timer or reversal distance, are controlled by the Primary operator regardless of the settings in the Secondary.
7. Once set as a Primary or a Secondary the operators will be in constant communication with each other. If that communication stops because the wires become severed or one operator is turned off, both machines will cease functioning and the LCD will display Err4, which is a Primary/Secondary communication error. This error cannot be reset until both machines are functional and communicating properly again.

NOTICE

Use a 2-pair, twisted, shielded cable with one pair of wires used to connect A-A and B-B terminals between the two boards. The other pair will connect the Common terminals. The shield should then be grounded on one end to one of the operators.

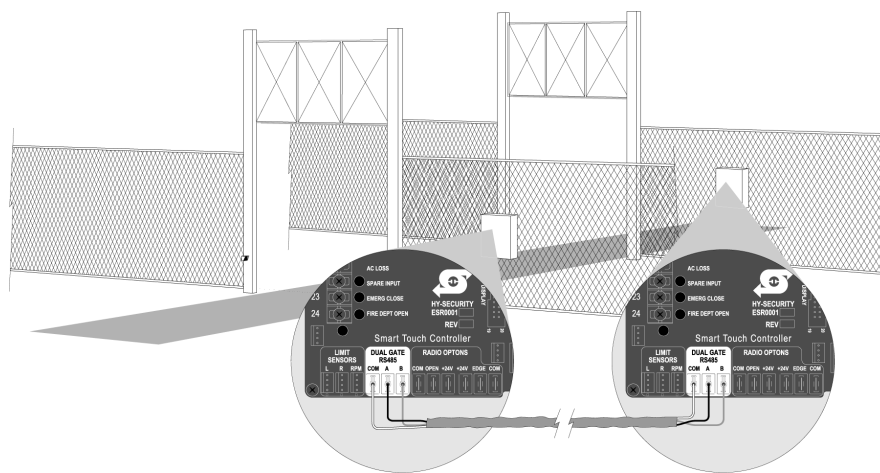

Figure 10. Dual Gate Connection

STC CONTROLLER USER MENU

INITIAL POWER UP

When power is turned on, the display will disclose the software revision:

Display Revision Number	2s delay	Displays software version Number, ex. [h3.02]
-------------------------	----------	---

System Data and Accessing the User Menu Settings:

If the gate is stopped in normal mode, pressing of the Menu button accesses the User Menu. After the menu button is pressed, the LCD will scroll the system data in the table below. The scrolling display stops at the close timer setting, which is the beginning of the User Menu. To exit the Menu Mode, the display must not be blinking, then simply pressing the Menu button will return the display to the Run Mode and re-enable the controls. The menu mode will also automatically return to the Run Mode if there is no activity for two minutes.

	Data Displayed in Scroll	Time	Description
S1	[SLAu] or [LEAd]	2s	SECONDARY Operator or LEAD Operator (PRIMARY)
S2	[ot 3] Gate type (1-5)	2s	Operator type: 1=HSG, 2=HRG, 3=HVG, 4=HTG
S3	[uC _] UL usage class (1-4)	2s	Installer setting of usage class: type 1-4
S4	[d___] 24VDC Buss Voltage	2s	Actual VDC buss voltage
S5	[CC__] Life cycle counter	2s	High digits of 6 digit life cycle counter
S6	[____] Life cycle counter	2s	Last 4 digits of 6 digit life cycle counter

STC CONTROLLER USER MENU

Read through the options available in the User Menu and the Installer Menu on the next page and you can see that the functions of this gate operator can be configured to suit most any specific need. Once you have learned to navigate the menus, as described in #2 on page 27 and how to change a menu setting, the full range of features and choices of the Smart Touch Controller are available to use. The User Menu contains the basic configuration items and the Installer Menu contains the more advanced menu items.

User Menu Options		Default	Description
U1	[Ct 0] Close timer setting	0	0 = Close timer off or 1 – 99 seconds
U2	[hC 0] Momentary Close	0	0 = momentary, 1= Constant hold PB required
U3	[ho 0] Momentary Open	0	0 = momentary, 1= Constant hold PB required
U4	[AP 0] AC Power loss function	0	0 – 3 (0 =Type A, 1 = B, 2 = C, 3 = D) See page 52
U5	[ro 0] Radio control option	0	0 = Open only, 1 = Adds close ability when full open
U6	[bF 2] Warn before operate	2	0 =off, 1 = Buzzer alerts 3 seconds before + in motion, 2 = Buzzer alerts 3 sec before + 2 seconds in motion
U7	[FA 0] Forced open Alert and automatic gate reposition	0	0 = off, 1 sound buzzer (2 pulses/sec) if forced open for more than four seconds, time out in 30 Sec
U8	[dA 0] Drift Closed Alert and automatic gate reposition	0	0 = off, 1 sound buzzer (2 pulses/sec) if drift closed and cannot reopen within four seconds.
U9	[PE 0] Photo Eye Align Mode	0	0= off, 1 = on (auto off when close limit triggered)
U10	[CL 0] Clock set (24 hour type)	0	0= display, 1= set mins, 2= set hours, 3= day, 4= month
U11	[Ld 5] LCD Contrast set	5	1 - 9 = Adjusts contrast of the display

These Notes Refer to the Menu Above:

- S1** Appears only if the operator is configured as a master or a slave unit
- U1** Close timer setting does not appear when set for constant contact close to function
- U4** Power loss function only appears if factory has provided DC type operator
- U6** We strongly advise never disabling the Warn Before Operate buzzer.

STC CONTROLLER INSTALLER MENU

The Installer Menu can be accessed only by entering the User Menu first, and then by pressing the Reset button and the Open button simultaneously. To restore the factory default settings, go to menu item [Fd_0] and change the setting to 1, then press the Program Menu button. The entire menu will reset to the factory defaults.

Installer Menu Options		Default	Description
11	[uC 0] Set UL Usage Class	0	0 = Gate disabled, Set Class 1 through 4 use
12	[Fd 0] Load Factory Defaults	0	0 = User settings, 1 = Load defaults (resets full menu)
13	[dg 0] Set Primary/Secondary type	0	0 = Solo operator, 1 = Secondary unit, 2 = Primary unit
14	[Ch 0] Set AC Charger or Solar	0	0 = DC + AC charger, 1 = DC + Solar charger
15	[Fo 0] Enable Fire Dept. Open	0	0 = input disabled, 1 = enabled
16	[oC 0] Enable Emergency close	0	0 = input disabled, 1 = enabled
17	[SE 3] Inherent Sensor sens.	3	1 = Maximum sensitivity, 9 = Lowest sensitivity
18	[SS 0] Inherent Sensor function	0	1 = stop only (note, functions in usage class 4 only)
19	[LC 0] Leaf delay Close	0	0 = none (1-7) ½ second steps (Primary/Secondary only)
110	[Lo 0] Leaf delay Open	0	= none (1-7) ½ second steps (Primary/Secondary only)
111	[rt 0] Maximum run timer	0	0 = 60 Seconds max run, 1 = 300 Seconds max run
112	[EC 0] PEC reverse to open	0	0 = Close eye stops only, 1 = 2 sec reverse to open
113	[PC 0] Set PEO/ PEC – NO/NC	0	0 = Normally Open PE output, 1 = N.C. (Supervised)
114	[gC 0] Set Edge input – NO/NC	0	0 = Normally Open Edge output, 1 = Normally Closed
115	[tC 1] Time clock/ Interlock input	1	0 = select Time Clock, 1 = select Open Interlock
116	[or 1] OOLD detector function	1	0 = pause closing only, 1 = enable reversing to open
117	[ir 1] IOLD detector function	1	0 = pause closing only, 1 = enable reversing to open
118	[dL 1] Vehicle detector logic	1	1 = std, 2 & 3= fast close timer, 4 = full anti-tailgate*
119	[r1 0] User relay 1 option	1	0 = disabled, 1 – 19 = see relay output options page 28

STC CONTROLLER INSTALLER MENU

Installer Menu Options		Default	Description
I20	[r2 0] User relay 2 option	6	0 = disabled, 1 – 19 = see relay output options page 28
I21	[r3 0] User relay 3 option	1	0 = disabled, 1 – 19 = see relay output options page 28
I22	tL 0] Gate Open alert	2	0 = 0 sec, 1= 15s, 2= 45s, 3= 75s, 4= 105s, 5= 135s
I23	[Lt 0] Loitering alert	3	0 = 0 sec, 1= 15s, 2= 45s, 3= 75s, 4= 105s, 5= 135s
I24	[ELd0] Test factory ELD*	0	0=Run, 1=show freq, 2=show call level 0-7, 3=set freq 1-4
I25	[iLd0] Test factory IOLD*	0	0=Run, 1=show freq, 2=show call level 0-7, 3=set freq 1-4
I26	[oLd0] Test factory OOLD*	0	0=Run, 1=show freq, 2=show call level 0-7, 3=set freq 1-4
I27	[SLd0] Test factory SLD*	0	0=Run, 1=show freq, 2=show call level 0-7, 3=set freq 1-4

NOTICE

See page 55 for description of vehicle detector & Loop Fault diagnostics

These Notes Refer to the Menu Above:

- I1** This setting must be configured or the gate cannot function and menu will not exit.
- I4** This setting appear only if the factory has provided a DC powered gate operator
- I8** IES stop only setting [SS __] does not appear unless set as a class 4 operator
- I9-10** These settings appear only if the Installer Menu is set for Primary / Secondary function
- I22-23** These settings appear only if the Installer Menu has set relays r1-r3 for these alerts

USER MENU FUNCTION DESCRIPTIONS

User 1 [Ct _] Close timer setting: This menu item is the automatic close timer for the gate. The factory setting is zero, which is off. It may be configured up to 99 seconds.

User 2 [hC 0] Momentary Close: This menu item is to configure for the system for constant hold push button Close function. The factory setting is zero, which is momentary contact input.

User 3 [ho 0] Momentary Open: This menu item is to configure for the system for constant hold push button Open function. The factory setting is zero, which is momentary contact input.

User 4 [AP 0] Power loss function: This menu item only appears if the operator is a DC battery powered version. This item is to configure what gate function will occur when the AC power fails. See page 52 for more detailed information on DC operators.

User 5 [ro 0] Radio control option: This menu item is to configure whether a radio input can open only (default) or if set to 1, also has the ability to close the gate when it is fully open.

User 6 [bF 2] Warn before operate: This menu item controls the warn before operate buzzer and can be configured three ways. Setting the menu item to zero turns the buzzer off, but we strongly advise leaving this valuable warning feature active to alert prior to gate motion. Never cut the wires to the buzzer or unplug it. Set to 1 and the buzzer will sound three seconds before motion and the entire time during gate motion. Set to 2 (default) and the buzzer will sound three seconds before motion and for the first two seconds of motion.

User 7 [FA 0] Forced open Alert and automatic gate reposition: This function is intended for highly secure facilities. If it is enabled, by setting the selection to 1, it will reinitiate a closure if a gate is somehow forced to open far enough that the close limit switch releases. The Alert buzzer will sound immediately, even if it had been turned off, and the motor will restart to secure the gate fully closed. If the gate is not fully closed within four seconds the motor turns off and the alert buzzer sounds an intruder alert for thirty seconds. The LCD display reads ALE1.

User 8 [dA 0] Drift Closed Alert and automatic gate reposition: If it is enabled, by setting the selection to 1, it will restore a gate to back its fully open position if it drifts closed for any reason. The buzzer will sound a warn before operate alert, even if it had been turned off, and the motor will restart to reopen the gate. The motor will run for a maximum of four seconds and if the gate is not fully open in this period, the buzzer sounds for ten seconds and the LCD display reads ALE2.

User 9 [PE 0] PE Alignment Mode: This feature may be activated as an aide to photo-eye emitter / receiver alignment. The buzzer chirps once as the photo eye is triggered or twice when the photo eye is released. The Alignment Mode is cancelled with any close limit input or reset input.

User 10 [CL 0] Clock and date set: The Smart Touch Controller is equipped with a 24 hour 365 day clock, so that events of significance can be logged and stamped with the time and date. This feature is useful to record historical operation data, which can be accessed via the RS232 port. To set or adjust the hour, minute, day or month, see page 31.

User 11 [Ld 5] LCD Contrast set: Under some extreme high or low temperature conditions, it may be necessary to adjust the contrast of the LCD display. The display is adjustable from 0-9 with a factory default setting of 5.
Installer 1 [uC 0] Set UL Usage Class: This menu item is used to set the UL usage class, which must be set by the installer before the operator will function. See "STC Installation Configuration" on page 28, step 3.

INSTALLER MENU FUNCTION DESCRIPTIONS

Installer 2 [Fd 0] Load Factory Defaults: This menu item is used to globally restore all menu settings back to new machine status. To activate, change the setting 0 to 1 and push the Menu button. The UL usage class and the hand configuration will need to be set again.

Installer 3 [dg 0] Set Solo, Primary or Secondary type: This menu item is used to configure an operator as a Primary or a Secondary operator in Primary/Secondary paired gate installations.

Installer 4 [Ch 0] Set AC Charger or Solar: This menu item appears on 24 VDC battery machines only and is set to solar only when there is no AC battery charger.

Installer 5 [Fo 0] Enable Fire Dept. Open: This menu item is used to enable the Fire Dept. Open input. When set to [Fo_1] this input will override vehicle detectors, photo eyes and gate edges to open a gate. A reset is required before the gate can be closed.

Installer 6 [oC 0] Enable Emergency Close: This menu item is used to enable the Emergency Close input. When set to [oC_1] this input will override vehicle detectors, photo eyes and gate edges to close a gate. A reset is required before the gate can be opened.

Installer 7 [SE 6] Inherent Sensor sensitivity: This menu item is to adjust the sensitivity of the internal inherent sensor. Available settings are 1-9, with 9 being the least sensitive.

Installer 8 [SS 0] Inherent Sensor function: This menu item is only available in UL class 4 operators and allows an option whereby the inherent sensor will only stop the gate.

Installer 9 [LC 0] Leaf delay Close: This menu item only appears if the operator is set up as a Primary or a Secondary. Available settings are 1-7. Each increment adds ½ second, to a maximum of 3 ½ seconds time delay, before the operator activates when commanded to close.

Installer 10 [Lo 0] Leaf delay Open: This menu item only appears if the operator is set up as a Primary or a Secondary. Available settings are 1-7. Each increment adds ½ second, to a maximum of 3 ½ seconds time delay, before the operator activates when commanded to open.

Installer 11 [rt 0] Maximum run timer: The maximum run timer has a default setting of 60 seconds. This menu item allows an optional setting of 300 seconds, if changed to [rt_1].

Installer 12 [EC 0] PEC (photo eye close) reverse to open: The default for this menu item is for non-reversal if the close photo eye is triggered. The optional setting of [EC_1] will cause the gate to reverse to open for two seconds if triggered while closing.

Installer 13 [PC 0] Set PEO/ PEC – NO/NC: The default for this menu item is for photo eyes with Normally Open outputs. The optional setting of [PC_1] will require a Normally Closed output. If set for N.C. the connection is also supervised and any open or short circuit fault will generate a FAL2 alert, which requires a Stop button reset to re-enable any function if triggered.

Installer 14 [gC 0] Set Edge input – NO/NC: The default for this menu item is for edge sensor with Normally Open outputs. The optional setting of [gC_1] will require a N.C. output.

Installer 15 [tC 1] Time clock / Interlock input: This menu item configures the input at terminal #7 to be either for the gate interlock function, or for an external time clock to open input. The default setting is [tC_1] for the interlock function.

INSTALLER MENU FUNCTION DESCRIPTIONS

Installer 16 [or 1] **OOLD (Outside Obstruction loop detector) function:** The default for this menu item is for full reversal when the OOLD is triggered. The optional setting [or_0] causes the gate to only pause when triggered. Closure begins as soon as the loop is clear again.

Installer 17 [ir 1] **IOLD (Inside Obstruction loop detector) function:** The default for this menu item is for full reversal when the IOLD is triggered. The optional setting [ir_0] causes the gate to only pause when triggered. Closure begins as soon as the loop is clear again.

Installer 18 [dL 1] **Vehicle detector logic:** This menu item is used to configure quick close logic. For vertical lift gates, there are four modes. See the full description on page 57.

Installer 19, 20, 21 [r1 0], [r2 0], [r3 0] **User output relay 1 - 3 programming options:** These three menu items are used to configure the function of the three user output relays. There are 19 optional choices, which are described in detail on page 28.

Installer 22 [t L 0] **Gate Open alert:** This menu item is to adjust the time delay before activating the user relay function #8, described on page 40. Time settings up to 135 seconds.

Installer 23 [Lt 0] **Loitering alert:** This menu item is to adjust the time delay before activating the user relay function #13, described on page 40. Time settings up to 135 seconds.

Installer 24 [ELd0] **Factory ELD:** Controls the Hy5B Free Exit detector, see page 55

Installer 25 [iLd0] **Factory IOLD:** Controls the Hy5B IOLD detector, see page 55.

Installer 26 [oLd0] **Factory OOLD:** Controls the Hy5B OOLD detector, see page 55.

Installer 27 [SLd0] **Factory SLD:** Controls the Hy5A Shadow detector, see page 55.

CORRECTIONAL FACILITY - USER OPTIONAL WIRING

A special terminal strip has been pre-wired in Correctional facilities models to the three user relay outputs for easy field wiring of the common interconnect options. If alternate output functions are required, see page 28, titled Options for User Programmable Output Relays 1-3.

Connecting an Interlocked Pair:

An interlocked pair of operators is not a Primary/Secondary system, but is simply two gate operators interlocked such that the one cannot open unless the other is fully closed. This connection is used frequently at correctional facilities for Sally Port gates. The Smart Touch Controller provides both an interlock input (#7) and the interlock output contact that is required.

1. User relay 1 on the Smart Touch Board has been set by the factory to provide the necessary interlock function. Connect a total of four wires between operator #1 and operator #2 as follows: One wire to the Common buss of each operator to the User 1 relay COM terminal of the other operator. Then, connect wires from the User 1 relay NC terminal to the Interlock input (#7) of the other operator.
2. If User relay 1 has already been used for a different function, then one of the other relays User 2 or User 3 must be wired as described above and set to output function 1. The user relays are configured in the Installer Menu as item [r1__], [r2__] or [r3__] according to the definitions described on page 40.
3. The interlock input, terminal #7, is convertible to alternately be a time clock input, so it is possible that it may need to be switched back for the interlock function. If this alteration is needed, go to the Installer Menu, and set item [tC_] to be [tC_1].

Connecting to an External Lock Mechanism:

An external solenoid lock or maglock can be controlled by the Smart Touch Controller to unlock just before gate motion begins.

1. User relay 2 has been set by the factory to provide the necessary output for a solenoid lock. Connect the voltage matching the lock solenoid to User 2 COM and connect a solenoid coil to User 2 NO (connect a maglock coil to User 2 NC). The un-switched solenoid or maglock wire connects directly to its supply voltage common conductor.
2. If User relay 2 has already been used for a different function, then one of the other relays User 1 or User 3 must be wired as described above and set to output function 6. The user relays are configured in the Installer Menu as item [r1__], [r2__] or [r3__] according to the definitions described on page 28.

Connecting the Gate Secure Position Indicator Output:

An external device can be signaled by the Smart Touch Controller to indicate the gate is secure.

1. User relay 3 has been set by the factory to provide the necessary output for position indication. Connect the voltage matching the indicator light to User 3 COM and connect the gate secure light to User 3 NC. The other indicator light wire connects directly to the voltage common conductor. If an unsecured light is required, connect it to User 3 NO.
2. If User relay 3 has already been used for a different function, then one of the other relays User 1 or User 2 must be wired as described above and set to output function 1. The user relays are configured in the Installer Menu as item [r1__], [r2__] or [r3__] according to the definitions described on page 40.

USER PROGRAMMABLE OUTPUT RELAYS 1-3 OPTIONS

The Smart Touch Controller can be set to interface to many types of external devices through the use of its programmable output relays. All of the output functions listed below are accessible in the Installer Menu under the selection [r1 __], [r2 __] and [r3 __]. Select which relay you wish to use and enter the appropriate function by the numbers as listed below.

- 1. Close Limit output:** This output can also be used to create an interlock signal to another operators interlock input, or simply to indicate that the gate is secure. The relay is released at full closure.
- 2. Close limit pulse output:** This output may be used in a sequenced system to command a 2nd machine to close. Generates a brief pulsed output that occurs when the close limit is triggered.
- 3. Open limit output:** This output is used to indicate a full open position indication. This output becomes active when to open limit is triggered and releases when the open limit is released.
- 4. Open limit pulse output:** This output may be used to trip a sequenced barrier arm gate operator to open. Generates a brief pulsed output occurs when the open limit is triggered. An additional pulse is also generated with any new open command even when the gate is already fully open.
- 5. Warn before/during operate output:** This output may be used to control an external warning device. This output will operate at the same time as the internal warn before operate buzzer.
- 6. Gate Lock output:** This output may be used to control external solenoid locks or magnetic locks. In both directions of travel, this output will be activated about 7/10th of a second before the operator starts moving the gate, and remains active while moving and for a few seconds after stopping.
- 7. Gate forced open output:** Alarms if the gate is forced off the closed limit switch, and operator is not able to restore the gate to full closed within four seconds. This alarm resets itself in 30 seconds.
- 8. Gate open too long output:** Activates when the gate has been open longer than a user-selected period of time. Adjustable from 0 delay, then 15 seconds delay to 135 seconds delay in 30-second time increments.
- 9. Safety Mode Alert output:** Activated when system is in the Safety Mode or the Entrapment Mode. Safety Mode occurs upon an impact with an obstruction. Entrapment Mode means the gate is stopped and occurs if the internal inherent sensor triggers while the system is in the Safety Mode.
- 10. Entrapment Mode Alert output:** Activated only when system is in the Entrapment Mode.
- 11. Unauthorized Vehicle Entry output:** Activated when a 2nd vehicle enters from the outside, without a valid input from an access control device. This output releases when an access control input signals open or the gate reaches the close limit position.
- 12. Outside Obstruction Vehicle Detector output:** This output may be used to interlock to an entry device to prevent pedestrian use. This output is active whenever the OOLD is tripped.
- 13. Special output from "OOLD" only when gate is closed:** Used to annunciate a vehicle or to indicate loitering. Adjustable from 0 delay, then 15 to 135 seconds delay in 30-second time intervals.
- 14. Gate nearing full travel output:** For operators with RPM sensors only. This output is activated when the gate is three feet from full travel in both the open and close directions. This output can be used to reduce the sensitivity of a proximity sensor near the ends of gate travel.

USER PROGRAMMABLE OUTPUT RELAYS 1-3 OPTIONS

15. **Gate Failure output:** This output is activated to report that a problem has occurred. Indicates that system in an Error Mode, Fault Mode or Entrapment Mode. If active, the gate is disabled.
16. **Motor Running output:** This output is active when the motor is running and the gate is in motion.
17. **AC Power Failure output:** This relay is normally energized, but drops with loss of AC power. This output is also active on DC machines when the battery charger is off.
18. **DC Power Failure output:** This output is activated when the battery power is very low, but the output ceases when the battery is dead. The relay is triggered when the battery is less than 20 Volts.
19. **Flasher Relay:** This output is intended to control flashing lights that pulse once per second. The relay is activated all the time, except when the open limit switch is triggered.

SETTING THE TIME AND DATE

The Smart Touch Controller is equipped with a 24 hour (military time), 365 day clock, so that events of significance can be logged and stamped with both the time and the date. This feature is useful to record key historical operational data and a log of Alerts, Faults and Errors, all of which can be accessed from the RS232 port with a PC computer or a PDA using the Palm OS. Optional Hy-Security supplied software and cables are required in order to read this data.

1. To set or adjust the time or date, go the User menu item [CL_0] and then push the Select button so that [CL_0] blinks. Press the Next button to change the setting from [CL_0] to 1, 2, 3 or 4 depending upon which setting is to be altered. 1 = minutes / 2 = hours / 3 = days / 4 = months.
2. Once you have selected a blinking setting [CL 1-4], push the Select button (Note: you must push the Program Menu button for software versions prior to h3.01) to change the display to a blinking (adjustable) value. The following letters will be displayed on the left side to aid in knowing which setting is being made:
 - a. Setting [CL 1] = minutes – display [ni 0–59]
 - b. Setting [CL 2] = hours ---- display [hr 0–23]
 - c. Setting [CL 3] = days ----- display [dA 1-31]
 - d. Setting [CL 4] = months – display [no 1-12]
3. Make any required change to the hour, minute, day or month in the typical manner by using the Next or Previous buttons, then press the Select button to enter the change, just as typical for all of our other menu settings.
4. When done, you may have to restore the setting to [CL 0] because the Menu button may not function to allow the user to exit the clock setting mode until the user has changed the setting back to [CL 0], which places the clock in its normal display mode.
5. A lithium disk battery supports the clock so that the time is not lost when the main power is off
6. This battery should be replaced about every five years. Use a DL 2025 / DL 2032 or CR 2025 / 2032 battery.

ENTRAPMENT PROTECTION DEVICE SCHEMATIC FOR VERTICAL GATES

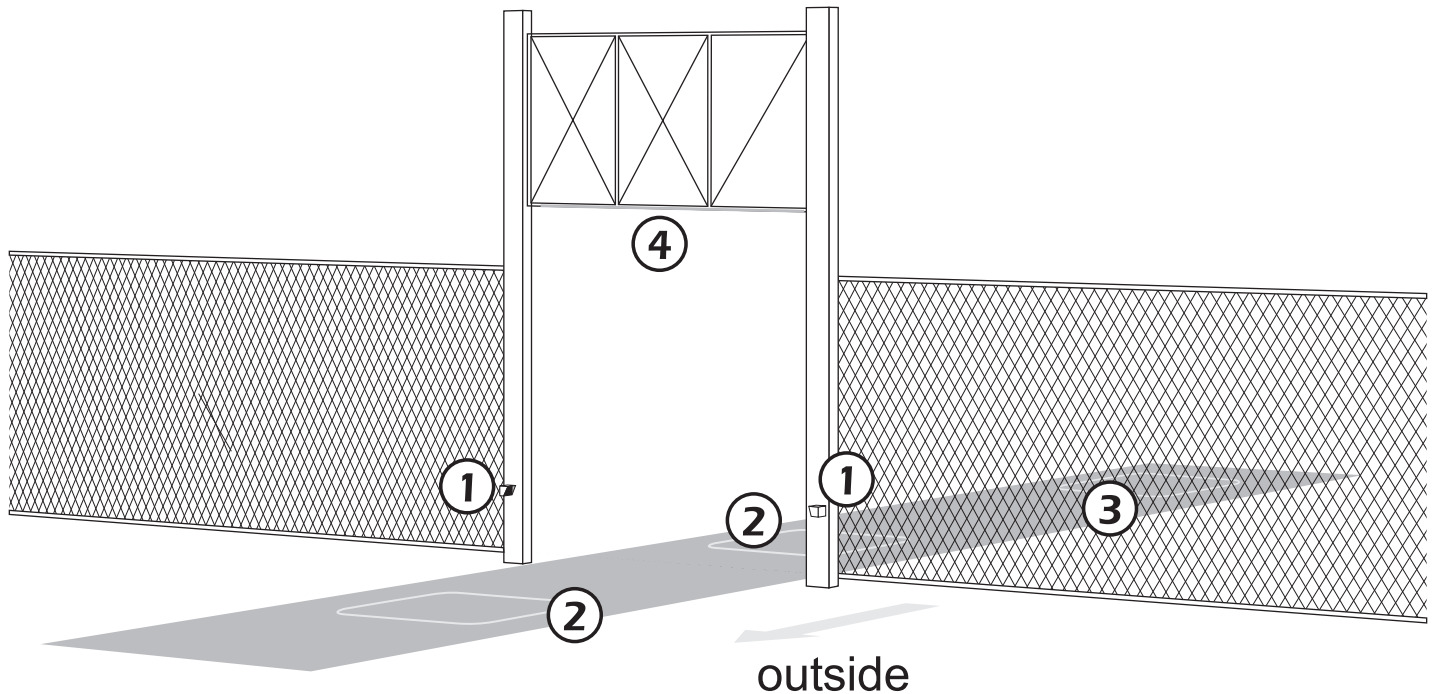

This figure illustrates a sample plan for a gate, incorporating the elements described below.

1. Photo eyes stop the gate to help prevent vehicular or personal entrapment.
2. Obstruction loops. (located inside and outside of the gate, and eight feet apart).
3. Optional free exit loop
4. Sensing edge on the bottom of the gate sends a signal to operator to stop and reverse when an obstruction is encountered.

This schematic view is not meant to recommend the only way to set up your configuration, but to point out the various elements of a proper automatic vehicular gate installation. The gate operator itself is only one component in the total system. Always install a separate pedestrian gate.

UL 325 ENTRAPMENT PROTECTION DEVICE STANDARD REQUIREMENTS

Table 2. Gate Operator Category

Horizontal Slide, Vertical Lift, Vertical Pivot, Swing and Vertical Barrier (arm)				
Usage class	Primary type^a	Secondary type^a	Primary type^a	Secondary type^a
Vehicular I and II	A	B1, B2, or D	A, or C	A, B1, B2, C, or D
Vehicular III	A, B1, or B2	A, B1, B2, D, or E	A, B1, or C	A, B1, B2, C, D, or E
Vehicular IV	A, B1, B2, or D	A, B1, B2, D, or E	A, B1, C, or D	A, B1, B2, C, D, or E

Note: The same type of device shall not be utilized for both the primary and the secondary entrapment protection means. Use of a single device to cover both the opening and closing directions is in accordance with the requirement; however, a single device is not required to cover both directions. A combination of one Type B1 for one direction and one Type B2 for the other direction is the equivalent of one device for the purpose of complying with the requirements of either the primary or secondary entrapment protection means.

^aEntrapment protection sensor types:

Type A - Inherent entrapment sensing systems.

Type B1 - A non-contact sensor (photoelectric sensor or the equivalent).

Type B2 - A contact sensor (edge sensor device or the equivalent).

Type C - Inherent adjustable clutch or pressure relief device.

Type D - An actuating device requiring continuous pressure to maintain opening or closing motion of the gate.

Type E - An inherent audio alarm, which warns a minimum of 3 seconds before operation.

UL Usage Class Information:

The automatic vehicular operator must also be labeled as appropriate for both the type and usage class of the gate. Installers must verify that the gate operator is labeled for the intended application.

NOTICE

Sliding gate operators installed in Class I & II applications must not move the gate faster than 12 inches per second.

Class I: Intended for use in a home of one to four single family dwelling, or a parking area associated therewith.

Class II: Intended for use in a commercial location or building such as a multi-family housing unit (five or more single family units) hotel, garages, retail store or other building servicing the general public.

Class III: Intended for use in an industrial location or building such as a factory or loading dock or other locations not intended to service the general public.

Class IV: Intended for use in a guarded industrial location or building such as an airport security area or other restricted access locations not servicing the general public, in which unauthorized access is prevented via supervision by security personnel.

SECONDARY PEDESTRIAN ENTRAPMENT SENSOR PLACEMENT AND USE

WARNING

To reduce the risk of serious injury or death, read and follow all instructions in the gate operator handbook and on the warning labels.

Automatic gate operators are intended only for vehicular use and pedestrians must be routed to a separate man gate, however sensors are still required in order to provide a degree of protection should anyone happen to stray into the area of an automatic gate. Generally there are two types of external sensors that may be used: Contact type sensors, such as an edge sensor, and non-contact sensors, such as photoelectric eyes. Current industry standards require the use of either type or both of these sensors, as a secondary device, in Class I and Class II automatic sliding gate installations, because the general public is likely to be present. Although there are alternatives for Class III and IV installations, we highly recommend the use of external sensors for all automatic gate applications.

The specifier or installer may choose either photoelectric eyes or edge sensors, or use these devices in combination, but both the open and closing directions of gate travel must be guarded. The UL 325 standard for automatic sliding gates specifically requires the following:

- One or more non-contact sensors (photoelectric eyes) shall be located where the risk of entrapment or obstruction exists, such as the perimeter reachable by a moving gate.
- One or more contact sensors (edge sensors) shall be located at the bottom edge of a vertical lift gate.
- A hardwired contact sensor shall be located and it's wiring arranged so that the communication between the sensor and the gate is not subjected to mechanical damage.
- A contact sensor that transmits its signal to the gate operator shall be located such that the signal is not impeded by building structures or other obstructions and shall function under its intended end-use conditions.
- The contact and non-contact sensors must be tested and labeled as "Recognized Components" under the UL 325 standard in order to be deemed acceptable for use in this application.

Study the entrapment protection schematic and consider your specific installation to determine where the greatest risk of entrapment exists. Locate the edge sensors and/or the photoelectric sensors accordingly. Be certain that a sufficient number of sensors are used so that both directions of gate travel are guarded.

GATE REVERSING EDGE (CONTACT TYPE) SENSOR INSTALLATION

1. Follow the guidelines in the Entrapment Protection Schematic to plan the most appropriate mounting position for the edge sensor to be installed. A requirement of the UL 325 standard is that an edge sensor be laboratory tested and “recognized” under UL 325.
2. Drill holes through the edge’s mounting channel and through the surface that each gate edge is to be mounted. Securely fasten every edge sensor.
3. Edge sensors that are not attached to the moving gate, such as post mounted sensors are wired in parallel and directly connected to the gate operator:
 - a. Always route the leads of the edge sensors to the gate operator so that they are protected from physical damage.
 - b. Connect one edge sensor lead to our common buss on the power supply board and the other to terminal #13, which is labeled Edge Sensor input.
4. Edge sensors may be used with an edge transmitter and a receiver in order to transmit to the gate operator. We do not recommend the use of retractable cord reels or curl cords because of durability problems with these devices in outdoor environments.
 - a. Mount the gate edge sensors to the leading edge and bottom edge of the gate so that entrapment protection is provided in both directions of travel.
 - b. Mount one or two edge transmitters (Linear Model #3022 or equivalent) onto the gate panel near the upper corner of the leading edge of the gate. All gate edges will function correctly if only one transmitter is used, but wiring multiple edges to a single transmitter may be impractical or displeasing visually.
 - c. Connect the edge(s) to the terminals in the edge transmitter and set the DIP switches of the transmitter to match the setting in the receiver to be used.
5. Mount a commercial style radio receiver* (external antenna type) on the inside of the operator, below the electrical box. Knock out the smallest hole in the lower right corner of the electrical box and route the wires to the area marked Radio Options. Only three wire connections are needed because the 24-Volt supply and the radio output share a wire. Being certain to observe polarity, crimp the black radio power wire together with one of the radio output wires into a .25” spade connector and connect to the COM terminal. Connect the red wire to the +24V terminal and connect the other radio output contact wire to the spade marked EDGE. Note that this terminal is the same as the #13 input terminal labeled Edge Sensor on the main control board.
 - a. Mount an external antenna onto the top of a fixed post of the fence near the operator.
 - b. Connect the antenna into the socket on the radio receiver.
 - c. Set the DIP switches in the receiver to match the same code used in the transmitter.
6. Test the operation of the reversing edge to make sure that it is functions correctly. Advise the user of the gate to be certain to retest this vital function weekly.

* If there is also to be a radio receiver for a hand held transmitter to operate the gate, be certain to use a two channel commercial receiver. Remember that the transmitter and receiver must have their codes set the same or they will not function.

INSTALLING PHOTOELECTRIC (NON-CONTACT) SENSORS

GENERAL INFORMATION:

Follow the guidelines in the Entrapment Protection Schematic to plan the most appropriate mounting positions for the photo-eye sensors to be installed. If there are no other secondary external entrapment protection sensors (typically an edge sensor), at least one photoelectric sensor is required to serve to stop the gate if an obstruction is present.

There are two common types of photoelectric sensors, through beam and retro-reflective, each has some advantages. A through beam sensor is generally more powerful and able to function reliably with dirty optics and in poor weather. A retro-reflective sensor has the convenience of not requiring the installation and electrical wiring of the remote emitter required in a through beam system, but is generally more problematic in poor weather. Avoid use of a retro-reflective device to span a distance greater than 24 feet in an outdoor environment or performance will probably be unsatisfactory.

COMPATIBILITY:

A requirement of the UL 325 standard is that a photoelectric sensor be laboratory tested and “recognized” under UL 325. In order to be compatible with a Hy-Security operator, a photo eye must be rated to function from 24 Volts DC source power.

INSTALLATION:

Mount the photo eye approximately 15” to 30” above the ground and as close to the gate as possible. Unless there are also gate edges for entrapment protection, a minimum of one photo eye will be required to function for the closing direction of travel. Mount the receiver on the post nearest the controller box and the emitter on the far post. In some situations, an additional photo eye should be installed on the public side of the gate. The installation locations described above are intended for pedestrian detection, if photo eyes are also to be used for vehicular detection, consider, in addition to the low elevation photo eye for cars, another photo eye at a height of about 55” to detect semi-trucks.

CONFIGURATION:

If the photo eye has an internal switch for setting Light Operate vs. Dark Operate, select Light Operate. If the photo eye has a relay output and has both NO and NC terminals, some experimentation may be required to determine the proper connection. This is because in the Light Operate mode the output relay is normally energized and releases when the beam is blocked. Some manufacturers label an output as NO, when it is actually an NC contact. If the photo eye has a solid-state output and provides the option of a sinking or sourcing connection, choose the sinking connection.

CONNECTION:

Three wires to the receiver and two wires to the emitter are all that is required.

- a. The +24 Volt source power is obtained from our power supply board.
- b. The –24 Volt source power is obtained from our terminals #14 or 15, labeled (Photo Eye Power) on the Smart Touch Controller board.

Note: The –24 Volt Photo Eye Power also supplies the photo eye Common.

- c. The photo eye NO or NC output connects to the Smart Touch Controller at terminal #19.

SUPERVISED CONNECTION:

If the photo eye being installed has a true NC output (one that is NC when the photo eye is powered, aligned and set for Light Operate) then a supervised connection is recommended. A supervised connection will signal a system Fault and prevent gate operation if the photo eye connection ever becomes an open circuit or a short circuit. The Installer Menu item [PC_0] must be changed to [PC_1] to enable this feature. See Installer menu 13 on page 34 and page 37.

INSTALLING PHOTOELECTRIC (NON-CONTACT) SENSORS

PHOTO EYE FUNCTION:

A tripped photo eye will prevent the gate from starting in either direction if the gate is stationary. If tripped while in motion, the standard function is to pause the gate motion and then automatically restart again if the photo eye is clear within five seconds. An optional setting in the Installer Menu will cause a 2 second reversal of travel. See Installer menu 12.

ALIGNMENT:

Most photo eyes require careful optical alignment in order to aim the emitter beam to the center of the receiver or reflector. In order to avoid false triggering, it is important to carefully align the system, especially with retro-reflective photo eyes. The best way to assure true centering of the beam is with some trial testing where the emitter is shifted to move the beam left and right and up and down until the range of the invisible cone of the infrared beam is known. Photo eyes usually provide alignment aid LED's for this setup, but they can be hard to see. Hy-Security has provided a unique feature that causes our buzzer to chirp when the photo eye enters and exits alignment. See User menu 9. Set the Installer menu item [PE_0] to [PE_1] and the buzzer will provide an audible indication both when the beam is broken and remade.

Notes about retro-reflective systems:

Correct installation and alignment of a retro-reflective photo eye and its reflector is important for a trouble free installation. Any system operating at a range greater than 16 feet is more prone to false triggering due to dirty optics, condensation or poor weather. If care is taken in the initial mounting and alignment of the 3-inch reflector, the chance of problems is greatly reduced.

Taking steps to protect the photo eye and the reflector from being exposed to fog and being absolutely certain the photo eye is perfectly aligned will greatly reduce any false triggering of the system. The ideal mounting of a retro-reflective photo eye is inside and enclosure of some sort.

The ideal mounting for the reflector is suspended inside a twelve-inch long piece of 3-inch PVC conduit. Cut the opening of the PVC conduit at a 45-degree angle to act as a drip shield. Hold the reflector against the backside of the PVC conduit by attaching a 3-inch male connector. Do not cement the connector, so that the reflector can be reached for future cleaning. To create a mounting base, attach a 3-inch aluminum flange (electric meter hub) to the connector. This whole package can be mounted to any flat surface.

Locate the reflector in the center of the invisible beam of infrared light to achieve the most sensitive alignment. The beam center is determined by the following test: while holding the reflector in your hand, slowly raise it until the beam is no longer returned, and the photo eye trips. Mark this maximum height. Now lower your hand and determine the lower limit of the infrared beam by watching for the trip point. Mark this position as well. Repeat the same procedure for left and right at the center elevation of the beam, as determined by the previous test. Once the four limits have been determined, either mount the reflector in the center of the area outlined or realign the eye for the position of the reflector. If the photo eye is realigned, be sure to perform the centering test again to verify that the reflector is truly in the center.

A last tip – if you coat the reflector with common dishwashing detergent, or some other anti-fogging compound, it will reduce fogging from atmospheric moisture.

DETECTOR BASICS

The vehicle detector passes a small current flow through the "loop" which then becomes an inductive coil. When a vehicle passes over a loop the detector senses the resultant drop in the inductance, and actuates the detector output.

LOOP CONFIGURATIONS

Configurations differ depending on the application. In parking applications with our HTG 320 operator, a loop may be as small as 3' x 6'. In a traffic application employing one of our sliding gate, swing gate or vertical lift gate operators, the smallest loop should not be less than six feet square.

RULES TO FOLLOW FOR SECURITY GATE APPLICATIONS

1. The side of the loop closest to the gate shall be located at least four (4) feet distant from its line of travel.
2. The shortest side of the loop shall be between six (6) and eight (8) feet in length. The longest side of the loop shall be between six (6) and twenty (20) feet in length. For applications that need to span a wide area, use several smaller loops. Do not exceed a maximum of 200 square feet of loop area to only one detector.
3. In applications with multiple loops, keep each loop at least six feet apart. This avoids "cross talk". It is possible to have loops closer together by selecting different frequencies. An advantage of using Hy-Security model Hy5B detectors is that problematic "cross talk" is not possible.
4. For greater sensitivity and less chance of false calls caused by the motion of the gate, it is better to use two smaller loops, connected in a series circuit, to one detector instead of one large, single loop.
5. To avoid interference, keep loops at least two (2) inches above any reinforcing steel. Do not route loop wires with, or in close proximity to, any other conductors, including other loop leads, unless shielded lead-in cable is used.

6. Loop and lead-in wire should be one continuous piece. Avoid splices, if possible. If a splice is necessary for any reason, "pot" the splice in epoxy or use heat shrink to ensure that the quality of the splice covering is the same as the original wire jacket.
7. Use only 14, 16 or 18 gauge stranded wire with a direct burial jacket. Cross linked polyethylene insulation types, such as, XLPE or XHHW, will last much longer and are less prone to damage during installation than conventional insulation types. Preformed loops can be used before road surfacing or under pavers.
8. Twist loose tails of lead-in wires tightly, approximately ten times per foot.

Twist lead-in at least 10 turns per foot



Like This



Not Like This

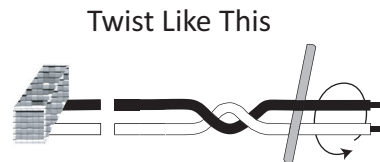

Twist Like This

Figure 11. Twist In Wires

9. Follow this guide for the correct number of wire turns according to the perimeter size of the loop:
 - a. 10 to 13 lf. = 5 turns
 - b. 14 to 26 lf. = 4 turns
 - c. 27 to 45 lf. = 3 turns
 - d. 46 to 100 lf. = 2 turns
10. This guide is written from a design perspective, but installation workmanship practices are equally important to insure proper operation and long loop life. The best way to insure a quality installation is to employ a professional installer experienced with detector loops. A few important practices are:

- The slot in the surface should be cut $\frac{1}{4}$ " wide x $1\frac{1}{2}$ " deep.
- The corners of the cut must be at an angle or core drilled to relieve stress on the wires. After the wire is installed, the slot must be completely backfilled with a non-hardening sealer.
- Note that if the loop wires are able to move in the slot after the sealer has set, the detector may give false calls.

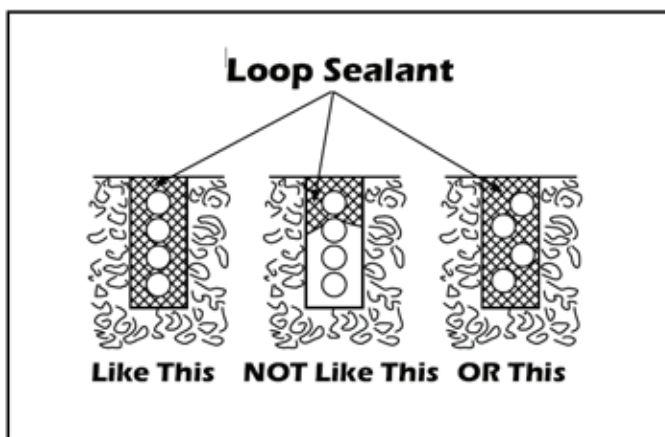

Figure 12. Loop Sealant

DETECTOR LOGIC

Hy-Security Gate Operators recommends that vehicle detectors be used for free open and obstruction sensing logic only. The exception is in parking applications with our HTG 320 operator where detectors may be also used to close the gate. In applications employing our swing, vertical lift, or sliding gate operators, closing logic cannot be used. Because of their slower speeds, closing logic is a poor choice for security gate systems. Since there are several ways that the gate may be left standing open and because there is a loss of safety.

LOOP DIAGNOSTICS

The following tests cannot guarantee a functioning loop, but failure of either test means that the loop is definitely suspect, even though it may still be functioning at the time.

TEST #1:

Resistance of the loop and lead-in wire should not exceed 4.0 Ohms.

TEST #2:

The resistance to earth, as measured with a 500V "Megger", should be 100 Megohms or more. Loops may function at 10 Megohms or less but will not be reliable (e.g. when the ground is wet from rainfall). Low resistance indicates broken or moisture saturated insulation. This is common if inappropriate wire insulation has been used.

Also see section titled "Detector & Loop Fault Diagnostics" on page 55 for additional tests that may be performed with Hy-Security Hy5B mini detector modules.

VEHICLE DETECTOR LOOP LAYOUT

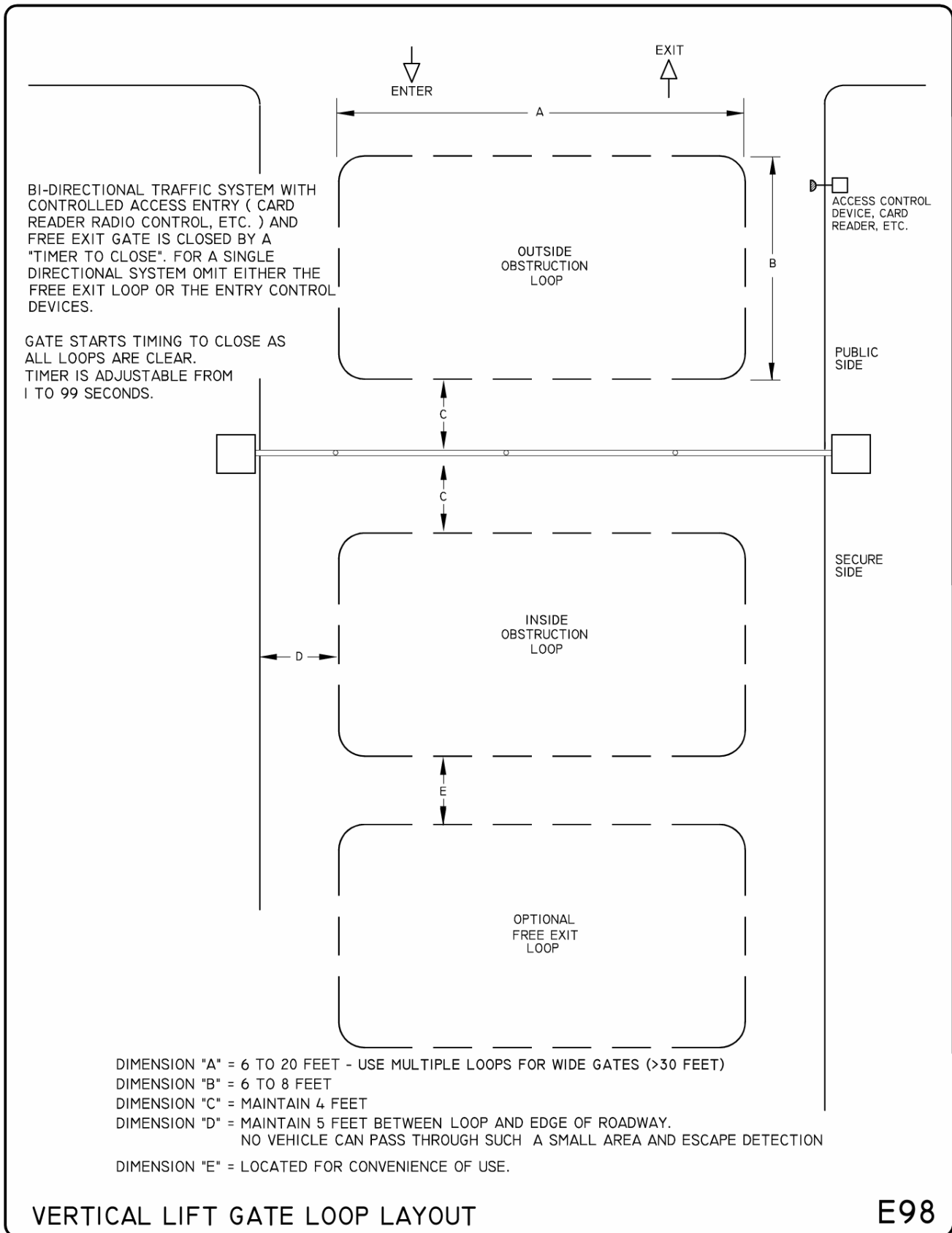

VEHICLE DETECTOR INSTALLATION OPTIONS

The Smart Touch Controller provides a feature rich interface to four different vehicle detector inputs. Standard box type 11 pin (24 Volt DC or 24 Volt AC) vehicle detectors may be connected in the traditional manner, see page 54. Hy-Security also offers a custom mini detector module that plugs directly into the Smart Touch Control board. Not only is the field installation much faster, but there is also a large performance benefit. The Hy-Security Hy5B detector is controlled by the Smart Touch microprocessor to achieve many benefits over common box type detectors*

- a. Loop frequency is automatically set and monitored by the Smart Touch Controller
- b. Cross talk between multiple loops is impossible.
- c. The best operating frequency for each loop is automatically chosen
- d. Smart Touch can report the both loop frequency and call strength on its LCD display
- e. Smart Touch will report loop malfunctions and store this data in its EEprom memory
- f. Most detector or loop faults that could occur are reported and displayed on the LCD display

There are four vehicle detector inputs available both on the main terminal strip and as direct plug in modules. The vehicle detector inputs are for the following functions

1. Free Exit Loop Detector – “ELD”
2. Outside Obstruction Loop Detector – “OOLD” (this is the outside reversing loop)
3. Inside Obstruction Loop Detector – “IOLD” (this is the inside reversing loop)
4. Shadow Loop Detector – “SLD” (this is for swing gates only)

*A combination of Hy5B detectors and standard box detectors is acceptable

It is not mandatory to use two separate detectors for inner and outer obstruction detection, however the benefits of using this additional detector are great. Several new features are possible, such as 2nd vehicle intrusion detection, a loitering alert and selectable non-reversing. Multiple obstruction detectors may be mandatory because not more than 200 sq-ft of loop area may be connected to any one detector or the sensitivity becomes inadequate.

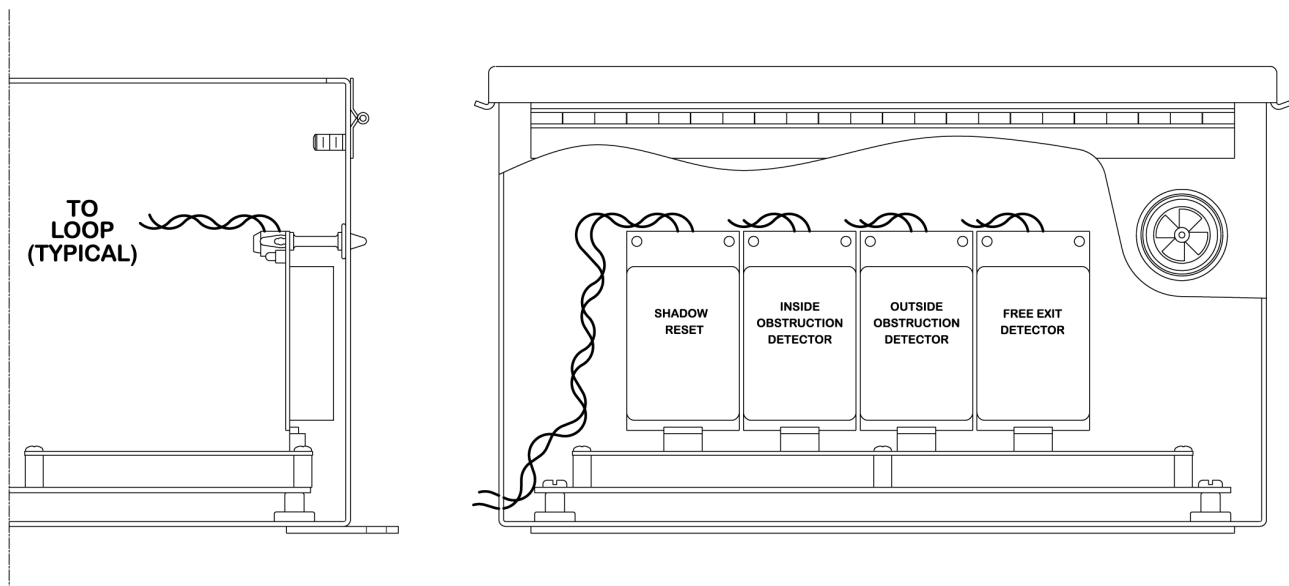

Figure 13. Vehicle Detector Installation

HY5B VEHICLE DETECTOR INSTALLATION

1. Insert the locking end of each of two 1" long white plastic standoffs into the mounting holes on the detector.
2. Plug the detector into the appropriate socket along the right side edge of the Smart Touch Controller board for the detector function that is desired. Be careful to align the six detector pins into the socket correctly, and then snap the standoffs into the holes on the right side of our control enclosure.
3. Route the loop wires through the wire clips provided and connect the loop leads to the two terminals directly on the detector. Tighten the terminal screws securely.
4. When the power is turned on, the detectors will immediately tune themselves.
5. Once enabled, if the detector module is unplugged, a communications alert [AL10] will be triggered, then if the fault continues, [Err3] "detector failed" is displayed. The operator will also run as if the affected detector is triggered. The [Err3] can only be cleared by pressing the Reset button, which electronically uninstalls the detector. See Detector & Loop Diagnostics on page 42.
6. The Smart Touch Controller automatically governs frequency selection of all Hy5B detector modules. This simplifies installation and guarantees that there is no cross talk between multiple loops. The frequency can also be manually selected if needed, see the installer menu options.
7. Sensitivity is the only adjustment on the detector itself. Generally sensitivity does not need to be increased unless the loop is large loop or there are multiple loops connected to one detector. Do not exceed more than 200 sq/ft of loop area to one detector.

The rotary switch for sensitivity has eight settings, which are as follows:

0 = Low, 1 = Normal, 2 = Medium, 3 = High (0-3 with the boost feature*), 4 = Low, 5 = Normal, 6 = Medium, 7 = High (4-7 no boost feature*)

*Boost increases the sensitivity during a call and is very useful for maintaining continuous detection when the signal may become weak, such as semi-trucks.
8. Vehicle detector functions are configurable in the Installer Menu as shown below.

The outside and inside Obstruction Loop Detectors "OOLD" or "IOLD" are factory configured to fully reopen the gate as a default setting. In the Installer menu, each detector can individually be set so that when the gate is closing there is only a pause if triggered. To change the IOLD setting, go to the menu item [ir__] and set to 0. For the OOLD, go to the menu item [or__] and set to 0.

* See page 43 for optional Vehicle Detector logic modes and anti-tailgate options.

Table 3. Hy5B Vehicle Detector Installation

Installer Menu Options		Default	Description
116	[or 1] OOLD detector function	1	0 = pause closing only, 1 = enable reversing to open
117	[ir 1] IOLD detector function	1	0 = pause closing only, 1 = enable reversing to open
118	[dL 1] Vehicle detector logic	1	1 = std, 2 & 3= fast close timer, 4 = full anti-tailgate*

STANDARD 11 PIN BOX TYPE VEHICLE DETECTOR INSTALLATION

1. If standard 11 pin vehicle detectors are to be used, snap up to three sockets onto the aluminum DIN mounting rail, with the key in the center hole facing to the left.
2. Both 24 Volts AC or DC are available, so either detector voltage may be used. (24 VAC is not available if the operator is a battery type) 24 VAC is available at the spade terminals on the lower left corner of our power supply (marked ACC). 24 VDC is available from the Common Buss and the +24 V spade terminals next to the common Buss.
3. Connect 24 Volt power to the detector. Polarity does not matter if the detector is a 24 AC model. If a DC detector is used, pin #1 is (+) on a DC detector and pin #2 is (-).
4. Connect the output pin #6 to the common Buss on the power supply and the output pin #5 to one of the four detector inputs (depending upon the detector function required) on the Smart Touch Controller terminal strip.
5. If multiple detectors are used, join the wires from socket to socket rather than run each to the same location separately. The only wire that must be separate is the output wire to the Smart Touch Controller as well as the loop input wires.
6. Always keep the loop wires well twisted at all places beyond the area of the loop. The lead in portion sealed in a saw cut does not need to be twisted so long as the wires are encapsulated in loop sealant and cannot move.

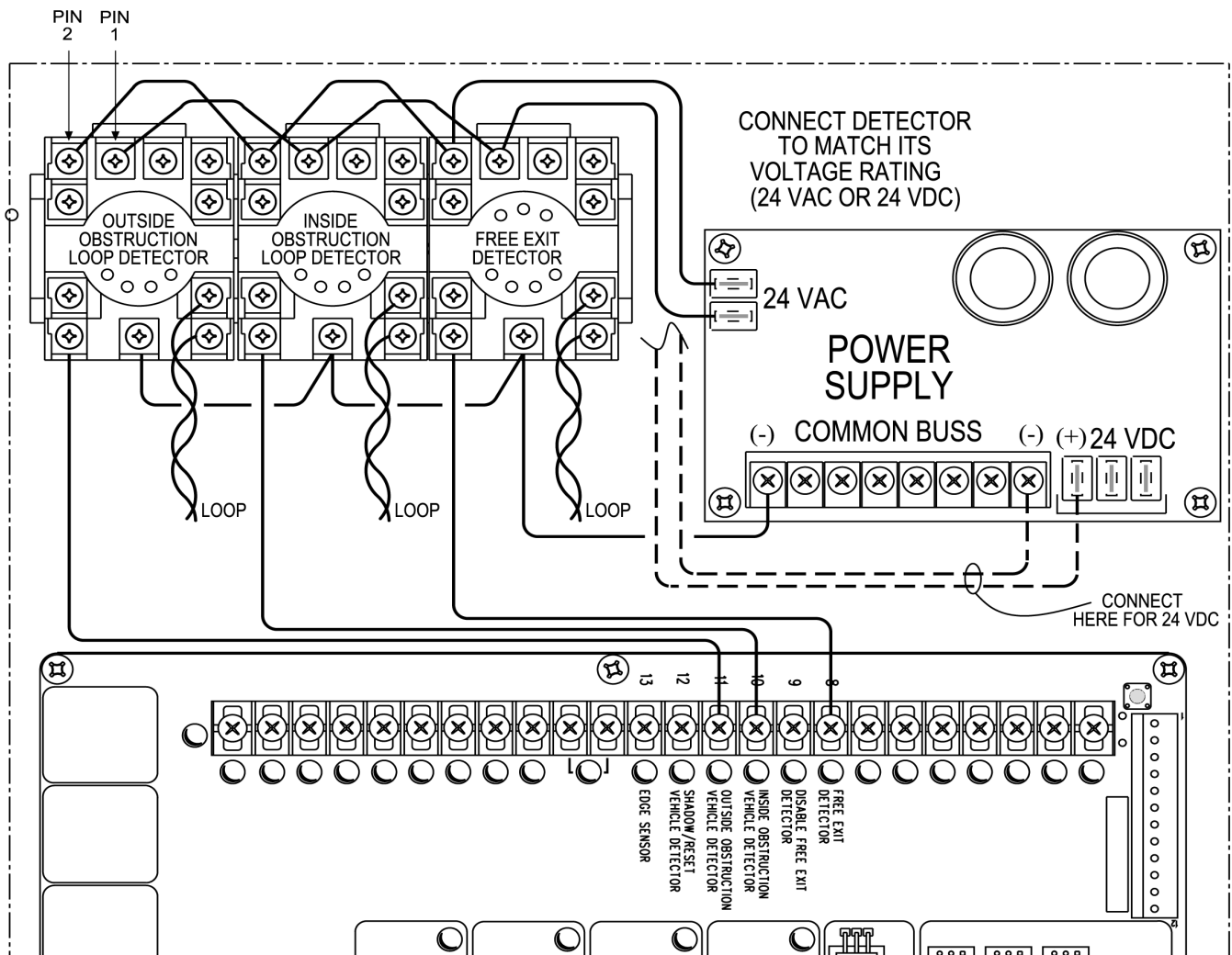

Figure 14. Standard 11 Pin Box Type Vehicle Detector Installation

DETECTOR & LOOP FAULT DIAGNOSTICS

If Hy-Security Hy5B mini detector modules are used, the Smart Touch Controller has ability to store and report detector and loop fault information for performance diagnostics. If The Smart Touch Controller senses a loop or detector problem, the LCD display will flash the abbreviation for the affected detector (ELd – ioLd – ooLd – SLd) then it will flash the appropriate Alert Code [ALE_] to disclose the nature of the problem and the buzzer will chirp.

Table 4. Loop Diagnostics

Loop abnormal freq change alert	ALE7	2 chirps/sec every 15 seconds
Loop shorted to ground alert	ALE8	2 chirps/sec every 15 seconds
Loop disconnected alert	ALE9	2 chirps/sec every 15 seconds
Loop detector active >5 minutes	AL12	2 chirps/sec every 15 seconds
Loop detector comm. alert	AL10	2 chirps/sec every 15 seconds
	AL11	2 chirps/sec every 15 seconds
Loop detector failed	Err3	3 chirps/sec once per minut

Even if the loop problem self heals, historical data about detector/loop performance and a log of Alerts, Faults and Errors can be retrieved from the Smart Touch Controller by downloading from the RS232 communications port. This requires optional Hy-Security software and cables, and a PC computer or a PDA using the Palm OS, in order to read this data.

FREQUENCY:

Knowing the exact frequency of a loop can be useful as a diagnostic tool and verifying that the loop frequency is stable is also very valuable information. To view the actual loop frequency of a specific vehicle detector, go to the setting for that detector, then change the selection to a flashing 1 and then press the Select button. The display will flash between [F_xx] which are the high digits, then the low digits of the loop frequency counter. For example: [F_05] + [3413] would represent a frequency of 53,413 Hertz. The highest digit will probably be only a single digit because loop frequency is usually a five-digit number, between 20,000 to 80,000 Hertz.

CHANGING THE LOOP FREQUENCY:

Hy5B detectors can never cross talk, but if for any reason, you want to manually change the loop frequency, change the menu selection to a flashing 4 and then press the Select button. Each detector has a choice of four frequencies. To exit, press the Menu button and the controller will perform a reset and tune to the new frequency setting.

DETECTOR & LOOP FAULT DIAGNOSTICS

CALL STRENGTH LEVEL:

Knowing the strength level of a detector call is valuable because it provides information about how well the loop is actually “seeing” a specific vehicle. For example, it may be useful to check to see if the loop is easily detecting the middle of a high bed semi-truck. The strength of a detector call can be displayed in real time, on a scale of 1-7. As indicated in the table below, when a detector’s menu setting is set to 2, and the Select button is pressed, the LCD display will read [LE_x]. If the call strength is level 4 or less, consider increasing the sensitivity level, by adjusting the rotary switch on the Hy5B detector.

Table 5. Call Strength Levels			
Installer Menu Options		Default	Description
I24	[ELd0] Test factory ELD*	0	0=Run, 1=show freq, 2=show call level 0-7, 3=set freq 1-4
I25	[iLd0] Test factory IOLD*	0	0=Run, 1=show freq, 2=show call level 0-7, 3=set freq 1-4
I26	[oLd0] Test factory OOLD*	0	0=Run, 1=show freq, 2=show call level 0-7, 3=set freq 1-4
I27	[SLd0] Test factory SLD*	0	0=Run, 1=show freq, 2=show call level 0-7, 3=set freq 1-4

Acronyms: Free Exit Loop = **ELd**, Outside Obstruction Loop = **oOLd**, Inside Obstruction Loop = **IoLd**
Shadow Loop Detector = **SLd** (this is for swing gates only)

VEHICLE DETECTOR CONFIGURATION & ANTI-TAILGATE MODES

STANDARD AND ANTI-TAILGATE MODES ARE SELECTABLE UNDER ITEM [DL__] IN THE INSTALLER MENU

(See installer menu #18 described on page 34 and page 38)

The detector function modes that result in Anti-Tailgating logic (modes 3 & 4 below) require the use of a separate inner and outer obstruction detectors.

In order to use any vehicle detector logic mode other than mode 1, all the loops must be placed with the geometry and spacing as shown in the loop layout drawing on page 51.

Mode 1: (Default) An input from either the Free Exit, OOLD, IOLD or the Shadow detector will hold the gate open, reset the close timer, and block all close inputs.

Mode 2: Same function as mode 1, except the close timer is allowed to time out, even with the Free Exit, OOLD, IOLD or Shadow detector inputs active. If the close timer has counted to zero, the gate will close when all detector inputs are clear.

Mode 3: Same functions of mode 1, however the close timer is forced to zero when both the OOLD & IOLD are tripped simultaneously. Additionally, any other close inputs are memorized and the gate closes immediately when all open commands and vehicle detector inputs are clear.

Mode 4: Full Anti-tailgate logic. Same as Mode 3 functions, plus the gate will stop during the opening cycle when both the OOLD & IOLD are tripped simultaneously. When the OOLD & IOLD loops are cleared, the gate closes immediately. The OOLD and IOLD can be individually set so that, if tripped while closing, the gate may pause only or reverse to reopen. In this mode, the free exit detector input, ELd, is blocked while the gate is closing.

STC 24HR/7DAY TIMER CONNECTION

This option generates an open command, which will hold the gate open until released.

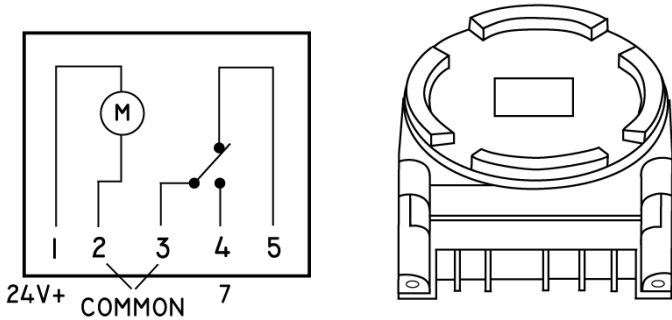

Figure 15. Timer Connections

7. Connect Timer Power Pin 1 to 24v (+).
8. Connect Timer Power Pin 2 to common.
9. Connect Timer Com Pin 3 to common.
10. Connect Timer NO Pin 4 to #7, Time Clock Open

SELECTING AM/PM OR MILITARY TIME

After pressing reset, the display may show AM. The numbered day symbols will be flashing on and off. If the display does not show AM, it is in military time mode. To change to AM/PM mode, press and hold the **h** key and press the **±1h** key once. AM will appear in display. If display is in AM mode and military mode is desired, press and hold the **h** key, press the **±1h** key once.

SETTING THE TIME

Press and hold the **⊕** key during the following:

(If Daylight Savings Time is in effect, press **±1h** first)

1. Press **h** to advance to the current hour, while holding down the **⊕** key.
2. Press **m** to advance to the current minute, while holding down the **⊕** key.
3. Press **Day** to advance to the current day, while holding down the **⊕** key.

NOTICE

If the days were flashing, it indicates the day of the week was not set when setting the time. The timer cannot be programmed unless the day of the week is entered. Each year, in the spring, press **±1h** to advance the time an hour. In the fall, press **±1h** to set back an hour.

PROGRAMMING 24 HOURS OR 7 DAY SCHEDULES

It is helpful to write out the programs schedules before beginning.

EXAMPLE:

Program 1: ON at 7:00AM Monday thru Saturday

Program 3: OFF at 7:00PM Saturday

Program 2: OFF at 5:00PM Monday thru Friday

These programs need to be entered:

Program 1

Press the ⊕ key once	ON symbol ⊙ appears
Press h key	to 07AM
Press m key	to 00
Press Day key once	123456 is displayed
Press Prog. key to enter	

Program 2

Press the ⊕ key once	ON symbol ○ appears
Press h key	to 05AM
Press m key	to 00
Press Day key twice	12345 is displayed
Press Prog. key to enter	

STC 24HR/7DAY TIMER CONNECTION

Program 3

Press the  key once ON symbol  appears

Press **h** key to 07AM

Press **m** key to 00

Press **Day** key twice until only 6 is displayed

Press **Prog.** key to enter

Press  key to enter Run Mode



IMPORTANT: If an "ON" time was programmed that is earlier than the current time, press  once to turn the timer "ON." (It does not "look back" to determine if it should be on or off after programming.)







Up to 20 Programs are able to be entered at one time.

REVIEWING PROGRAMS

To review the programs at any time, press **Prog.** key. Programs will appear in the order they were entered with repeat presses of the **Prog.** key. After all programs have been reviewed, the blank display will appear to allow entering another program.

MANUAL OVERRIDE

TEMPORARY: While in the run mode, pressing, the  key once will reverse the output; ON to OFF, or, OFF to ON. The  symbol appears in the display to indicate a temporary override. At the next scheduled switching time, automatic control resumes eliminating the override. Continuous: While in the run mode...

- Pressing the  key twice will turn the output to ON permanently.  symbol appears in display.
- Pressing the  key three times will turn the output to OFF permanently.  symbol appears in display.
- To terminate a continuous override, press the  key until  appears in the display.

CONNECTING A RADIO RECEIVER

Mount a commercial style 24-Volt radio receiver (external antenna type) on the inside of the operator, below the electrical box. Knock out the smallest hole in the lower right corner of the electrical box and route the wires to the area marked Radio Options. Only three wire connections are needed because the 24-Volt supply and the radio output share a wire. Being certain to observe polarity, crimp the black radio power wire together with one of the radio output wires into a .25" spade connector and connect to the COM terminal. Connect the red wire to the +24V terminal and connect the other radio output contact wire to the spade marked OPEN. Note that this terminal is the same as the #4 input terminal labeled Edge Sensor on the main control board.

Mount an external antenna onto the top of a fixed post of the fence near the operator.

Connect the antenna into the socket on the radio receiver.

Set the DIP switches in the receiver to match the same code used in the transmitter.

If there is also to be an edge sensor transmitter to reverse the gate, be certain to use a two channel commercial receiver. Remember that each transmitter and receiver must have their codes set the same or they will not function.

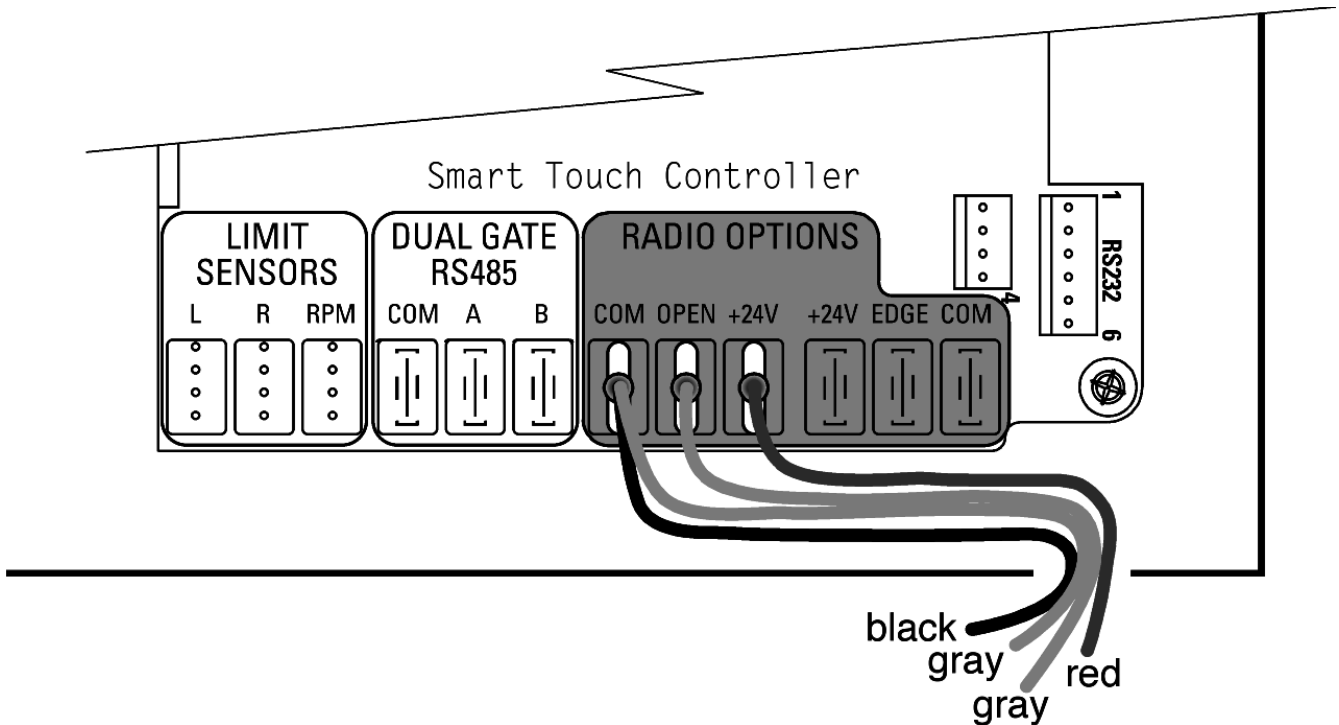

Figure 16. Connecting a Radio Receiver

TROUBLE WITH GATE MOVEMENT IN GENERAL:

1. Watch the pressure on the gauge while the gate is running. The gauge is a sensitive indicator of any spots that may be binding during travel. The pressure should be around 1,000 PSI and equal to slightly higher when closing and steady throughout the travel of the gate.
2. Stand away from the gate to verify that it is level, if not adjust the auto level cables.
3. Inspect the release sprockets in the base of each post and make certain the cap screw is tight.

ELECTRICAL PROBLEMS IN GENERAL:

The Smart Touch Controller reports system malfunctions on its LCD display and the buzzer will emit a series of chirps at defined intervals. Review the matrix of Alerts, Faults and Errors listed on the next page. To disclose the status of all inputs on the terminal strip, the LED tact button must be pushed. This button is in the upper left corner near the Stop input.

SPECIFIC TYPES OF PROBLEMS:

"I pushed the open and close buttons, but nothing runs."

1. Verify that the line voltage is present and matches the operator voltage + 10%.
2. In three phase applications insure that all three legs of line voltage pass through the power disconnect switch to the motor contactor, in case one of the lines is dropped somewhere.
3. Verify that control voltage is present at the power supply Common and 24VDC terminals. It may be necessary to reset the circuit breaker (black button) on the transformer.
4. Verify a jumper wire joins Common to Stop, if an external stop button is not used.
5. Verify there are no Faults or Errors reported on the LCD display. See table on the next page.
6. If the motor contactor chatters, voltage drop due to undersized wires is the likely cause. Check page 56 for maximum allowable length of wiring runs vs. wire size.

TROUBLESHOOTING

"The pump is running but the gate panels don't move."

(Hydraulic pressure is between 0 - 1000 PSI on the gauge)

1. If the power is three-phase, verify CCW motor rotation and reverse any two AC lines if needed.
2. Check the level of the hydraulic oil by removing the plug in the reservoir. If necessary, add oil at this location to within one inch of the filler hole.
3. Unplug the hoses and run the pump, look at the pressure gauge to confirm the system pressure reaches 2000 PSI. Re-attach the hoses when complete.
4. If relief pressure is not attained, remove the relief valve entirely and depress the plunger at the nose end with a blunt tool (large Allen wrench) and blow it to remove any debris. Return the valve to the power unit once cleaned.

"Hydraulic pressure is above 1000 PSI"

1. Verify that the quick connectors at the hose ends are fully seated when connected.
2. Check the brake valves where the hoses connect to the pump. They must not be turned too far counter-clockwise. See adjustment instructions on page 26.
3. Grab the gate panel and make certain it floats in its tracks, if it is bound fix the misalignment.

"The gate panels move in the wrong direction."

1. Check hose connections to verify the correct order of connection according to page 24.
2. With the system engaged to open, verify that the Open Valve coil develops a strong pull. (This can be tested by removing the nut retaining the coil and grasping the coil)

"The pumps starts correctly, but the gate only opens or only closes."

1. If the gate only opens, the directional valve is probably stuck and needs replacement.
2. If the gate only closes, the valve coil is not being energized, or is defective.

TROUBLESHOOTING

The Smart Touch Controller system includes many self diagnostic capabilities. The LCD will display specific messages and the Audio Alert buzzer will sound distinctive chirps. Any Alerts, Faults or Errors are also logged into a memory and stamped with a time and date. For diagnostic purposes, these messages can be retrieved with optional WinLogger software available from Hy-Security Gate.

The following chart is a listing of codes that would appear on the LCD display if problems are detected by the Smart Touch Controller.

Table 6. Troubleshooting		
Error, Fault, or Alert Status	LCD Display	Buzzer Chirp Sequence
Cannot respond due to tripped sensor or in Entrapment mode	Entr	2 chirps/sec every 2 seconds while control input is active
Safety Mode Alert	SAFE	2 chirps once when in Safety Mode
Low 24V Control Voltage Alert	Lo24 (ac or dc)	N/A (display flashes 1 sec every 5 seconds)
Critical Low 24V supply power	BadP (ac or dc)	N/A Display steady – controls disabled
Dead 24V Battery Alert –DC only	bat - dEAd	3 chirps upon any operating command
Gate forced open Alert	ALE1	2 pulses/sec for 30 seconds
Gate drift closed Alert	ALE2	2 pulses/sec for 10 seconds
Motor thermal overload Alert	ALE4	2 chirps/sec every 15 seconds
Both limits tripped Alert	ALE5	2 chirps/sec every 15 seconds
Loop abnormal freq change alert	ALE7	2 chirps/sec every 15 seconds
Loop shorted to ground alert	ALE8	2 chirps/sec every 15 seconds
Loop disconnected alert	ALE9	2 chirps/sec every 15 seconds
Loop detector comm. alert	AL10	2 chirps/sec every 15 seconds
Loop detector function alert	AL11	2 chirps/sec every 15 seconds
Loop detector active >5 minutes	AL12	2 chirps/sec every 15 seconds
Maximum run Fault	FAL1	1 chirp once every 15 seconds
Photo eye Fault (supervised)	FAL2	2 chirps/sec once per minute
Critical AC sag – bad supply wire	FAL3	2 chirps/sec once per minute
Directional motion Error	Err1	3 chirps/sec once per minute
Disconnected IES Error	Err2	3 chirps/sec once per minute
Loop detector failed	Err3	3 chirps/sec once per minute
Primary/Secondary RS485 comm. Error	Err4	3 chirps/sec once per minute
EEPROM Data Error (factory)	Err7	3 chirps/sec once per minute

Table 7. Troublshooting

EEPROM Data Error (installer)	Err8	3 chirps/sec once per minute
EEPROM Data Error (user menu)	Err9	3 chirps/sec once per minute
Program Data Error	FAiL	3 chirps/sec once per minute

The green LED near #2 on the terminal strip is the heartbeat of the processor. This LED should always blink brightly to indicate normal operation.

GATE SPEED: The speed in which a hydraulic operator moves a gate is determined by the size of the pump and the size of the actuator components. Just like a gear box, this speed is not adjustable. Attempting to slow a gate by changing any valve setting will cause a great deal of inefficiency and heat. If the speed of a gate must be changed, contact your Hy-Security distributor. Extremely cold weather is unlikely to seriously affect the speed of the gate, because Hy-Security employs a special grade of hydraulic oil that we call UNIFLOW oil, which maintains a very linear viscosity over a broad range of temperatures. Because of this high quality oil and other design considerations, we rate our operators for service in ambient temperatures of -40F degrees to 130F degrees. If the speed of your operator has been affected by cold weather, verify that the gate hardware is not impaired by ice and verify that the reservoir it is filled with UNIFLOW oil. In severe conditions, consider adding a heater.

GENERAL MAINTENANCE: HVG OPERATOR

OPERATOR POST

After proper installation of the Hy-Security Vertical Lift Gate Operator, very little maintenance will be required to insure long and trouble free operation.

Quarterly:

3. The primary maintenance is to maintain the drive chain tension. The tension can be easily checked with the gate in the fully open position. Grasp the chain that is exposed on the outside of the post, it should always be slightly taut and never be loose. If adjustment is necessary:
 - a. Expose the chain adjustment area by removing the 2nd access cover, which is about three feet above the ground and raise the gate until fully open.
 - b. Locate the threaded rod connection to the bottom of the weight cage. Loosen the bottom locking nut and tighten the upper locking nut until there is appropriate chain tension. Be certain to retighten the locking nut.

Semi-Annually:

1. Each post has four bearings, which should receive one pump from a grease gun semi-annually.
2. Check the auto level cables for correct tension. With the gate in a level position, the cables should neither sag nor greatly compress the spring at the top of each post. Also inspect the cables for fraying, especially where they bend over the sheaves when the gate is closed.
3. Inspect the cable sheaves to make certain they rotate freely.
4. Apply a light spray oil to all of the chains.

HYDRAULIC SYSTEM

Fluid Level: Under normal conditions, hydraulic systems do not consume oil. Before adding any oil, check the system thoroughly for leaks. Remove the bright metal plug in the tank, fill to plug level, then replace plug. We recommend our Uniflow hydraulic oil; part number **H004 1.0**, which is sold in one-gallon containers by our distributors. Automatic transmission fluid may be used, although its performance in cold weather will be sluggish unless the operator is well heated. **Never use brake fluid. It will severely damage the entire hydraulic system.**

Look for leaks: Occasionally there may be slight seeping at the fittings after some usage. Tightening of the fittings will usually correct the problem. If the leaking persists, replace "O" rings, fittings or hoses, if required. No further leaks should occur.

Oil Change: A hydraulic system does not foul its oil, unlike a gas engine, so oil changes do not need to be frequent. Oil breakdown caused by heat is the main concern. If the unit is subjected to high use, especially in a warm climate, change the oil more frequently. In general, we recommend draining the reservoir and replacing the oil at five-year intervals.

To change the hydraulic oil, remove the reservoir from the pump unit and completely, empty it. Wipe the reservoir clean and clean any debris from the pickup screen before re-assembling. Refill with new Uniflow hydraulic oil (available from your distributor). To avoid overfilling, fill only through removable plug near the top of the tank. Slowly pour the oil into the tank until the oil is within one inch of the filler port. Replace the plug and wipe up any spilled oil. If any oil is allowed to remain, it will dry to a very sticky and messy consistency.

Semi-Annually:

1. Check that your reservoir is filled with our Uniflow high performance oil, which is rated to -40°F.
2. Ice can partly or totally jam gate operation. In severe weather inspect the gate for excessive build-ups of snow and ice.

GENERAL MAINTENANCE

ELECTRICAL CONTROLS

Before servicing, turn off power disconnect switch

No routine maintenance is needed for the electrical system or controls. If the environment is very sandy or dusty, or has many insects be certain to seal all holes in the electrical enclosure. Blow the dust out of the electric panel with compressed air. A qualified technician may troubleshoot with the aid of the troubleshooting guide in this appendix. If it is necessary to call a distributor for assistance, be sure to have your model and serial number ready. Other helpful information would include the name of the job, approximate date of installation, and the service record of the operator, especially any work that has been done recently.

PRESSURE RELIEF VALVES ADJUSTMENT PROCEDURES

To check your relief valve setting, first disconnect the hoses. Run the operator either open or closed (the gate will not move with the hose disconnected). The relief valve is found on the rear of the hydraulic power unit. It has an adjusting head and lock nut. To adjust, loosen the lock nut and screw the threaded bolt clockwise for increased pressure, counterclockwise to decrease pressure.

Table 8. Factory Pressure Relief Setting	
Model	Factory Setting
HVG 420 & HVG 460	2000 PSI
HVG 420 EX & HVG 460 EX	2000 PSI

There is only limited value in using the relief valve as an entrapment protection device. Photo Eyes or gate edges are the best methods to protect pedestrians and maintain reserve power to reliably drive the gate.

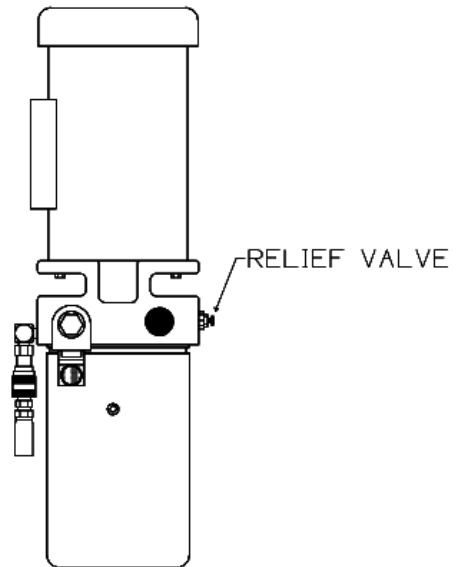

Figure 17. Timer Connections Pressure Relief Valves Adjustment

MAINTENANCE SCHEDULE

VERTICAL GATE OPERATOR MAINTENANCE SCHEDULE

Table 9. Vertical Gate Operator Maintenance Schedule

Name of Part	What To Do	Check at these recommended monthly intervals					
			1	3	6	12	60
Gate Panel	Check for damage	*1	X				
Gate tracking	Check for even pressure	*2		X			
Chain tension	Check for tightness	*3		X			
Lubrication	Oil chains, grease bearings	*4			X		
Limit Switches	Check normal function	*5			X		
Auto Level Cable	Check tension & gate level				X		
Anchor Bolts	Check for tightness					X	
Fluid level	Check for loss of fluid	*6				X	
Hydraulic fluid	Drain and replace fluid						X
Clock battery	Replace	*7					X

Special Notes:

*1 Your gate will usually require more maintenance than the Hy-Security operator that is moving the gate. Damaged or warped gate panels are signs that a vehicle may have hit the gate. Verify that the actuator post is not also damaged.

*2 Normally, the gate moves with no scraping sounds and a steady pressure displayed on the gauge. If there is any damage, misalignment or maladjustment, the gate motion will not be smooth and the gauge will display pressure spikes in the stiff areas of travel. These conditions must be corrected.

*3 The drive chain should always have a slight tension. If necessary, adjust the chain tension at the bottom of the counterweight cage.

*4 The bearings in the post and all the chain should receive light lubrication every six months.

*5 To perform this inspection simply watch the position the gate stops. If adjustment is necessary, you will need to remove the lowest cover on the post, open the limit switch cover, and follow the instructions on page 14. Also see the brake valve adjustment instructions on page 16.

*6 The oil level should remain approximately one inch below the filler hole. See maintenance instructions for oil filling. Loss of fluid is not normal and indicates a leak that must be located and repaired. Use "Uniflow" fluid, part H 004 1.0, if additional fluid is required.

*7 Replace the clock battery on the Smart Touch board with DL 2025 / DL 2032 or CR 2025 / CR 2032.

D.C. POWERED GATE OPERATOR SPECIAL NOTES

The on/off switch on the electric control panel of the drive unit does not disable all DC power to the operator, even if the AC power has been disabled at its source. The large rotary switch in the DC power supply enclosure must be actuated off to insure disconnect of all DC power to the drive unit.

The disconnect in the power supply must be off if the AC source power will be absent for more than one week. This avoids slowly discharging the batteries into the battery charger. Batteries will self-discharge and therefore the DC power supply must not be stored for a period longer than 6 months without recharging the batteries.

Batteries contain sulfuric acid. If batteries are dropped or damaged, be cautious not to get acid in the eyes, on skin, or on clothing.

Be certain to observe polarity when connecting the batteries, or adding accessories. Reversed polarity may result in a non-functional operator or possibly damage a component. Red is (+) positive, and black is (-) negative.

Since the electrical current under load is very high, be certain that the minimum conductor size, specified in the installation instructions, is used for the connection between the battery pack and the operator. If the battery pack is more than 20 feet from the operator, use a larger wire size, according to the distance between the operator and the batteries.

If shorted, batteries will generate a very high current. Observe special care when connecting the cables to the batteries that the polarity is correct. The batteries are connected in a series circuit: join the positive (+) terminal from one battery to the negative (-) terminal of the next battery.

Since this operator is intended to run on batteries, control of the load is important. Easier moving gates will drain less energy from the battery, preserving capacity for more cycles during a power failure.

Hy-Security uses a permanently sealed type battery, which needs no maintenance over its life span. A low voltage-sensing circuit protects the batteries from damage which could be caused by over-discharge. The charger automatically regulates its output to allow high output when the battery is partially discharged. The output will automatically be reduced to zero as the batteries become fully charged.

Batteries have a finite life. As the batteries age they will lose some of their capacity to store energy. If the total amount of back up capacity is critical, plan to replace the batteries after 5 years of use. Properly dispose of or recycle used batteries.

Batteries are rated to perform to capacity at a temperature of 77 degrees Fahrenheit. Below 77 degrees, the "amp hour" capacity is temporarily reduced. For example, at freezing, the capacity is 75%, at 10 degrees Fahrenheit, the capacity is 50%. Hy-Security insulates the battery pack to guard against this loss. Do not remove any insulation or the performance of the system may be adversely affected.

Batteries can be damaged by excessive heat, which may shorten their life span. Therefore, do not paint the battery enclosure a dark color that could cause it to absorb a lot of heat from sunlight.

D.C. OPERATOR WIRING AND CONTROL CONFIGURATION

If this installation is a 24-Volt DC battery type gate operator, there are a few additional steps that must be completed before the system can be functional. Review the installation instructions below and the connection diagram on page 70.

Be certain the DC power disconnect switch is turned off before making any connections.

3. Connect minimum 2 gage wires between the battery enclosure and the gate operator as follows: **Be certain to observe polarity carefully!**
 - a. From the battery enclosure the (+) lead connects to the lug on the large rotary power disconnect switch. The (-) lead connects to the lug on the circuit breaker. At the gate operator the (+) lead connects directly to the lug on the top of the DC electric motor. The (-) lead connects to the bottom lug on the contactor mounted alongside the DC motor. All lug connections must be tightened very securely since they pass high current to the gate operator.
4. Connect two separate 14-gage circuits between the battery enclosure and the gate operator. One circuit provides the 24 VDC to the gate operator controls and the second circuit is required so that the Smart Touch Controller knows that the battery charger is operating normally on AC power. Be certain to observe polarity carefully!
 - a. Connect four wires to the terminal strip in the battery supply labeled: (+)24, (-)24, COM, #21. The 24 Volt (+) and (-) terminals connect to the red (+) and black (-) wires at the on/off power switch in the gate operator.
 - b. The COM and #21 terminals connect to the Common Buss and to terminal #21 (Charger AC power loss) on the Smart Touch Controller.

5. The Smart Touch Controller User Menu (U4) provides four optional system configurations for 24- Volt DC battery type gate operators. Since this is an uninterruptible power supply system, the installer must decide, depending upon customer preference, what is to happen when the AC line power fails. There are four functional choices provided in the User Menu, item [AP__].

Setting 0 (Type A): The operator functions normally until the batteries drop to 20 Volts, then auto open and lock until the battery voltage recovers to 23.5 Volts. The gate can still be manually closed only by a Close Pushbutton or an Emergency Close input and will then re-open by any open command until the battery voltage drops to 17 Volts at which time the gate is absolutely locked open.

Setting 1 (Type B): The operator functions normally until the batteries drop to 20 Volts, then auto close and lock closed until battery voltage recovers to 23.5 Volts. The gate can only be opened by a special combination of a Stop Pushbutton input, then within 1 second, an Open Pushbutton input. The Fire Department open input can open the gate without the special PBS enabling pre-input. The gate can be reclosed only by Close Pushbutton and the Emergency Close inputs. When the battery voltage drops to 17 Volts, the gate completes its final cycle and stays in the full open or full closed position, depending upon which cycle was last.

Setting 2 (Type C): The operator automatically opens five seconds after loss of AC power and locks open, until AC power is restored. The gate can still be manually closed only by a Close Pushbutton or an Emergency Close input and will then re-open by any open command until the battery voltage drops to 17 Volts at which time the gate is absolutely locked open.

Setting 3 (Type D): Same as type C, except the operator initially does nothing after loss of AC power, but then locks open after the next open command of any type.

BATTERY CONNECTION DIAGRAM

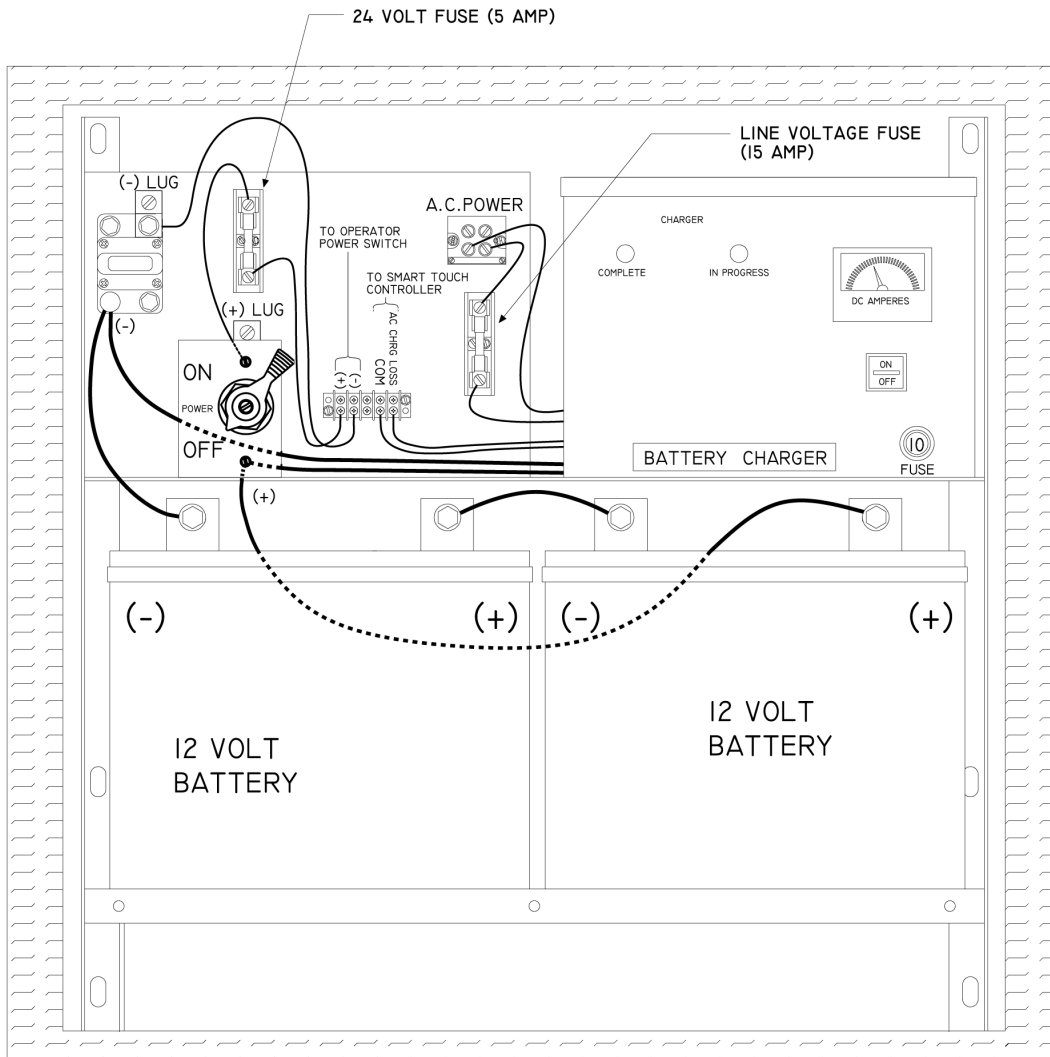

CONNECT SIX WIRES TO GATE OPERATOR AS SHOWN.

FOUR 14GA. WIRES TO CONTROL CIRCUIT
 CONNECT FROM LUG
 TERMINALS TO DC MOTOR:
 TWO 2 GA. MINIMUM FOR ALL HVG MODELS

INSTALL BATTERIES AS SHOWN, OBSERVING POLARITY.

ALWAYS OBSERVE POLARITY CAREFULLY.
 ALWAYS CONNECT RED WIRES TO (+) AND BLACK
 WIRES TO (-) EXCEPT FOR WIRES CONNECTING THE
 BATTERIES.

24V-100 A.H. BATTERY POWER SUPPLY FOR DC OPERATORS

BATTERY CONNECTION DIAGRAM

CONNECT SIX WIRES TO GATE OPERATOR AS SHOWN.

FOUR 14GA. WIRES TO CONTROL CIRCUIT

CONNECT FROM LUG TERMINALS TO DC MOTOR: TWO 2 GA. MINIMUM FOR ALL HVG MODELS

INSTALL BATTERIES AS SHOWN, OBSERVING POLARITY.

ALWAYS OBSERVE POLARITY CAREFULLY. ALWAYS CONNECT RED WIRES TO (+) AND BLACK WIRES TO (-) EXCEPT FOR WIRES CONNECTING THE BATTERIES.

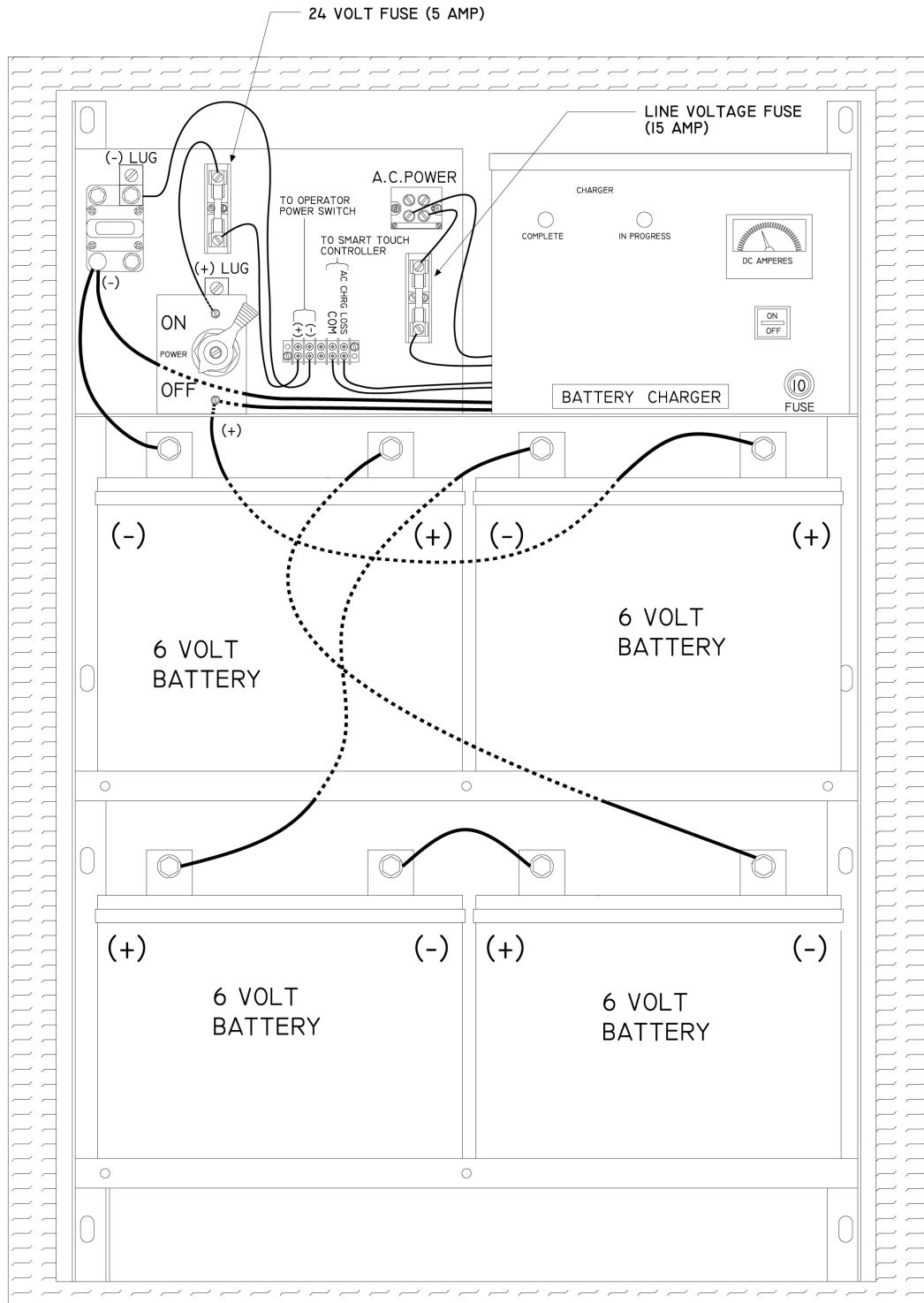

24V-170 A.H. BATTERY POWER SUPPLY FOR DC OPERATORS

WIRE SIZE SCHEDULES

For 1/2-hp through 5-hp motors

Supplying a gate operator with the right electrical service is crucial to the way the performance of the operator the life of its electrical components. If the wire size used is too small, the voltage loss—especially during motor starting—will prevent the motor from attaining its rated horsepower. The percent of horsepower lost is far greater than the percentage of the voltage loss. A voltage loss could also cause the control components to chatter while the motor is starting, substantially reducing their life due to the resultant arcing. There is no way to restore the lost performance resulting from undersized wires, except to replace them; therefore it is much more economical to choose a sufficient wire size at the initial installation.

The tables on the following page are based on copper wire and allow for a 5% voltage drop. The ampere values shown are the service factor ampere rating (maximum full load at continuous duty) of the motor.

Always connect in accordance with the National Electrical Code, article 430, and other local codes that may apply.

The maximum distance shown is from the gate operator to the power source; assuming that source power is from a panel box with adequate capacity to support the addition of this motor load. The values are for one operator, with no other loads applied to the branch circuit. Avoid placing more than one gate operator to a circuit, but if you must be certain to reduce the maximum allowed distance by half.

Wire Size for Voltage Drop Over Distance

Wire Sizes for Power Wiring, Single Phase Distances are shown in the unshaded boxes

Amps Horse Power	115 V, SINGLE PHASE						208 V, SINGLE PHASE						230 V, SINGLE PHASE					
	10.0	11.06	14.4	27.2	NA	NA	5.5	6.1	7.6	14.2	16.2	NA	5.0	5.8	7.2	13.6	14.8	27.0
12ga	90	75	60	30			290	260	205	110	100		350	300	245	130	120	65
10ga	140	120	100	50			460	415	330	175	155		560	480	385	205	190	105
8ga	220	190	155	80			725	650	525	280	245		880	760	610	325	300	165
6ga	350	300	245	130			1,150	1,040	835	445	390		1,400	1,120	975	515	475	260
4ga	555	480	385	205			1,825	1,645	1,320	710	620		2,220	1,915	1,550	815	750	410
2ga	890	765	620	330			2,920	2,630	2,110	1,130	1,000		3,550	3,060	2,465	1,305	1,200	660

Wire Gauge

Wire sizes for Power Wiring, Three Phase Distances are shown in the unshaded boxes

Amps Horse Power	208 V, THREE PHASE						230 V, THREE PHASE						460 V, THREE PHASE					
	2.7	3.1	4.2	6.5	6.7	16	2.4	3.0	3.8	6.2	6.4	15.4	1.2	1.5	1.9	3.1	3.2	7.7
12ga	590	510	375	245	235	100	730	585	460	280	270	115	2,915	2,350	1,850	1,130	1,100	455
10ga	930	810	600	390	375	160	1,160	930	730	450	435	180	4,640	3,710	2,930	1,800	1,740	725
8ga	1,475	1,285	950	615	595	250	1,835	1,470	1,160	710	690	285	7,340	5,870	4,650	2,840	2,750	1,150
6ga	2,350	2,045	1,510	975	945	400	2,925	2,340	1,845	1,130	1,095	455	11,700	9,350	7,400	4,550	4,400	1,800
4ga	3,720	3,240	2,390	1,545	1,500	630	4,625	3,700	2,920	1,790	1,735	720	18,500	14,800	11,700	7,200	7,000	2,900

Wire Gauge

Always connect in accordance with the National Electrical Code, article 430, and other local codes that may apply.

HVG PUMP PACKS - PARTS BREAKOUT

AC MOTOR

Start Switch
(60 Hz, 1 phase only)
EMOSS 012

Capacitor
(60 Hz, 1 phase only)
EMOCP 645 774

DC MOTOR

DC Motor Starter
ESWMC 080 MERC

or

HVG 420/460

DC Electric Motor
HVG - EMOSO DC6 2.02

HVG 420/460 - AC Electric Motor

60 Hz 1 phase - EMOB6 215 2.0E
3 phase - EMOB6 235 2.0T

50 Hz 1 phase - EMOB5 215 2.0E
3 phase - EMOB5 234 2A0S

*See next page for HVG EX models

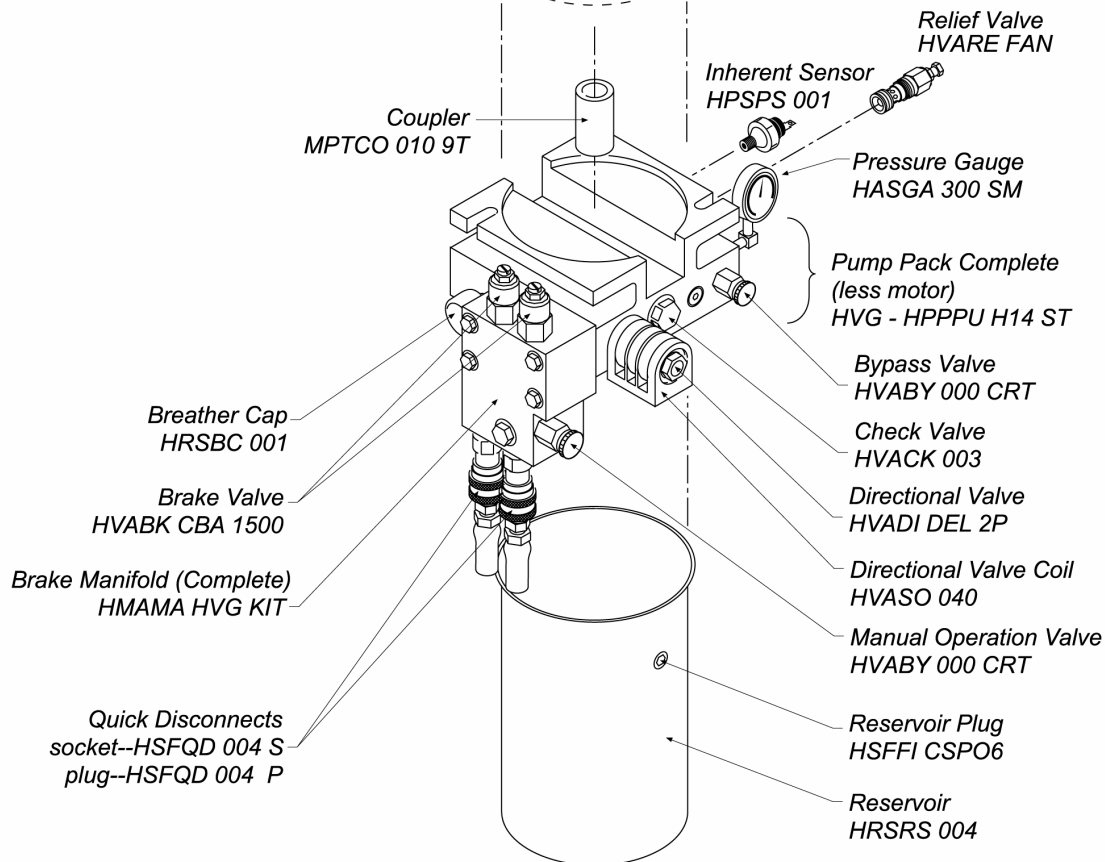

HVG 420 and HVG 460

HVG EX PUMP PACKS - PARTS BREAKOUT

AC MOTOR

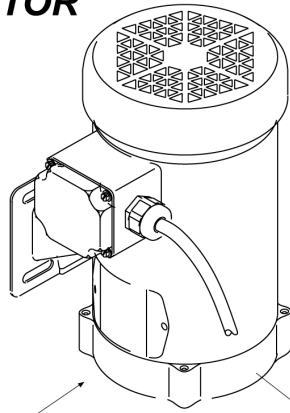

DC MOTOR

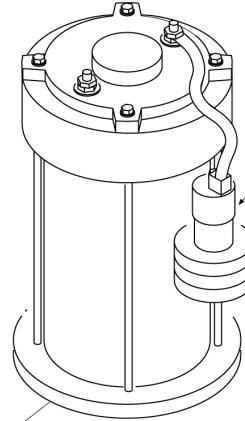

DC Motor Starter
ESWMC 080 MERC

HVG 420/460 EX
DC Electric Motor
HVG - EMOSO DC6 4.02

or

HVG 420/460 EX - AC Electric Motor
60 Hz 1 phase - EMOB6 215 5.0W
3 phase - EMOB6 236 5.0C
50 Hz 3 phase - EMOB5 236 5.0C

AWOG Hose
HMAAC 111 H

Relief Valve
HVARE LAN

HVAPL PB00

Inherent Sensor
HPSPS 001

Soft Start Manifold
(Complete Kit)
HMAAC 111 SSK

Coupler
MPTCO 010 9T

Pump Pack Complete
(less motor and valve coils)
HVG EX - HPPPU H19 ST

Pressure Gauge
HASGA 300 SM

Bypass Valve
HVABY 000 CRT

Check Valve
HVACK 003

Directional Valve
HVADI DEL 2P

Directional Valve Coil
HVASO 040

Manual Operation Valve
HVABY 000 CRT

Breather Cap
HRSBC 001

Brake Valve
HVABK CBA 1500

Brake Manifold (Complete)
HMAMA HVG KIT

Quick Disconnects
socket--HSFQD 004 S
plug--HSFQD 004 P

Reservoir Plug
HSFFI CSPO6

Reservoir
HRSRS 004

HVG 420 EX and HVG 460 EX

PARTS BREAKOUT - HVG CONTROL BOX

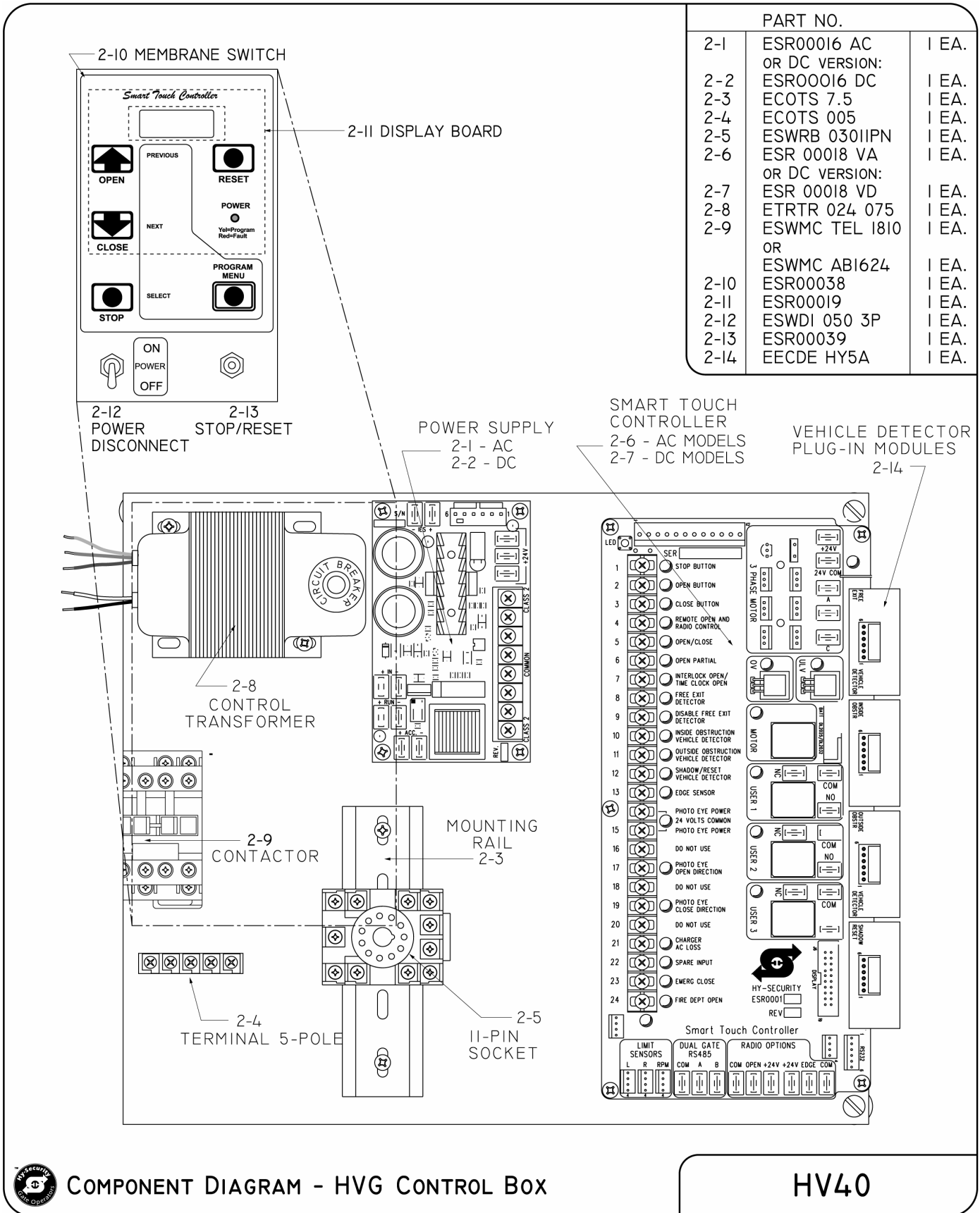

COMPONENT DIAGRAM - HVG CONTROL BOX

HV40

PARTS BREAKOUT - DC POWER SUPPLY

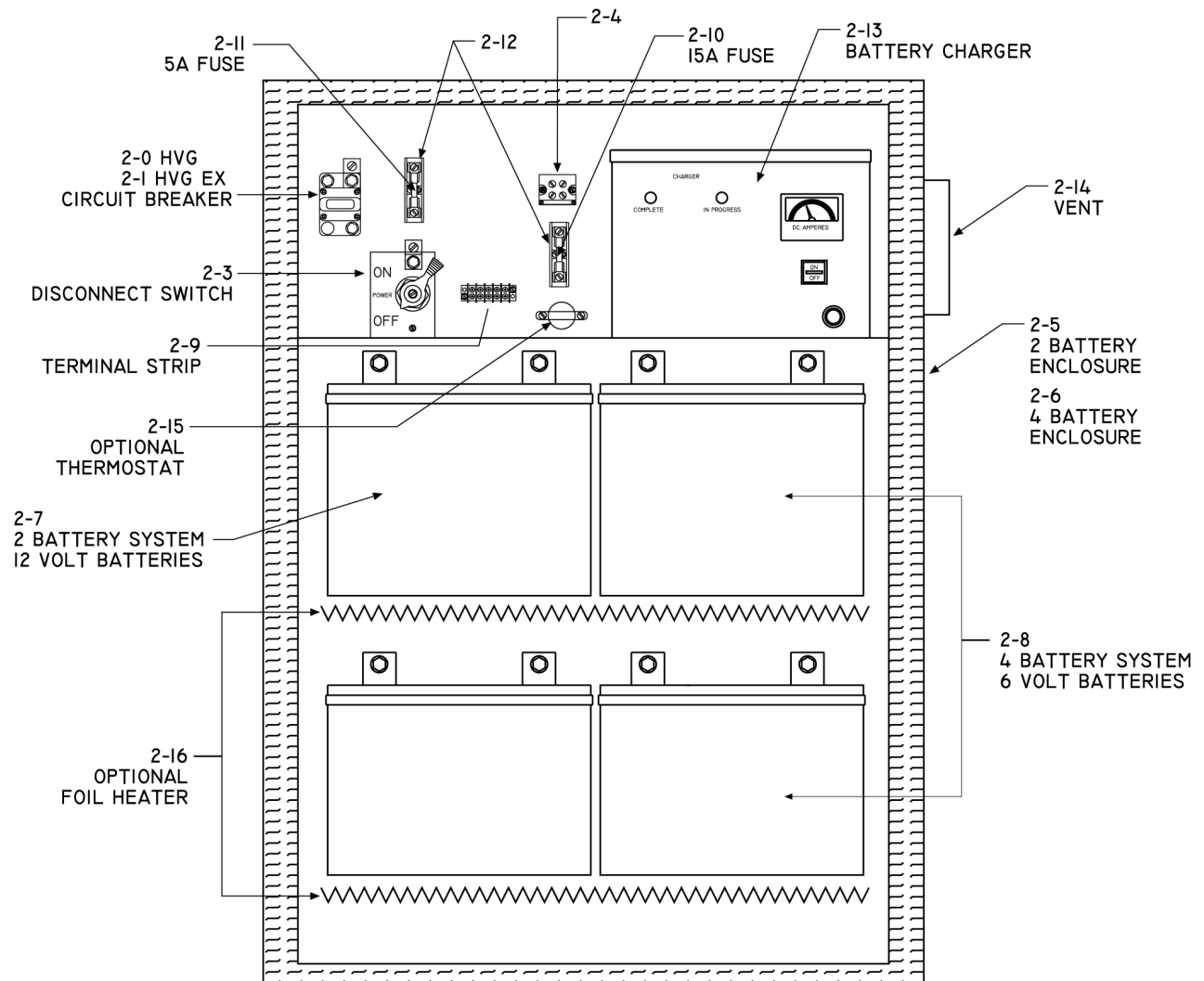

ITEM NUMBER	QTY	
2-0	ESWCB 030 120	1 EA.
2-1	ESWCB 030 150	1 EA.
2-3	ESWDI 067 DCEX	1 EA.
2-4	ECOTS 1102	1 EA.
2-5	EENEN HO1 3030	1 EA.
2-6	EENEN HO1 4230	1 EA.
2-7	EDCBY 12B 090	2 EA.
2-8	EDCBY 06V 170	4 EA.
2-9	ECOTS 005	1 EA.
2-10	ESWFU 010 15	1 EA.
2-11	ESWFU 010 05	1 EA.
2-12	ESWFU 001 BLK	1 EA.
2-13	EDCBC 024 025	1 EA.
2-14	EDCFV 001	1 EA.
2-15	EACTH B10 021	1 EA.
2-16	EACHE 120 65W	2 EA.

COMPONENTS BATTERY PACK FOR DC OPERATORS

PARTS BREAKOUT - DC POWER SUPPLY

Table 10. HVG420 Parts

Part Number	Description
ESWLS 228 VG	Rotary Limit Switch Complete
ESWLS 228 CB	Limit Switch Contact (component of above part)
H MOMO K10H	Hydraulic Motor W/Quick Disc. Fittings
H SFHO 006 4216	3/8" Hydraulic Hose, With Fittings
H SFQD 004 P	1/4" Quick Disconnect (Plug)
H SFQD 004 S	1/4" Quick Disconnect (Socket)
M VLSV 001 5.0	5" Plastic Double Cable Sheave
M TBTC 001	1/8" Auto level Cable with End Fittings, sold by L/F
M PTBE 020	UHMW Angle Glide for Bogie
M PTBE 025	1" Tapped Base Pillow Block Bearing
M VLSP 420 T-R	Top Shaft and Sprocket Assembly (2 Sprockets)
M VLSP 420 B	Bottom Shaft and Sprocket Assembly (3 Sprockets)
M PTSP 001 3B12	#35-12 Tooth Limit Switch Sprocket
M PTSP 400 R	#40-19 Tooth Quick Release Sprocket
M PTRC 040	#40 Roller Chain, Plated
M PTRC 035	#35 Roller Chain, Plated (Limit Switch)
M PTRC 040 CON	#40 Master Connecting Link
M PTRC 040 Off	#40 Offset Connecting Link
M VLBO 420	Bogie (Gate Mount for HVG 420)
M VLWC 420	Weight Cage (for HVG 420)

PARTS BREAKOUT - DC POWER SUPPLY

Table 11. HVG460 Parts

Part Number	Description
ESWLS 228 VG	Rotary Limit Switch Complete
ESWLS 228 CB	Limit Switch Contact (component of above part)
H MOMO K10H	Hydraulic Motor W/Quick Disc. Fittings
H SFHO 006 4216	3/8" Hydraulic Hose, With Fittings sold by L/F
H SFQD 004 P	1/4" Quick Disconnect Set (Plug)
H SFQD 004 S	1/4" Quick Disconnect Set (Socket)
M VLSV 001 5.0	5" Plastic Double Cable Sheave
M TBTC 001	1/8" Auto level Cable with End Fittings, sold by L/F
M PTBE 020	UHMW Angle Glide for Bogie
M PTBE 015	1-1/4" Tapped Base Bearing
M VLSP 460 T-R	Top Shaft and Sprocket Assembly (2 Sprockets)
M VLSP 460 B	Bottom Shaft and Sprocket Assembly (3 Sprockets)
M PTSP 001 3B12	#35-12 Tooth Limit Switch Sprocket
M PTSP 400 R	#40-19 Tooth Quick Release Sprocket
M PTRC 050	#50 Roller Chain, Plated (Main support)
M PTRC 040	#40 Roller Chain, Plated (Motor Drive)
M PTRC 035	#35 Roller Chain, Plated (Limit Switch)
M VLBO 460	Bogie (Gate Mount for HVG 460)
M VLWC 460	Weight Cage (for HVG 460)

APPENDIX A - FRENCH TRANSLATIONS

FRENCH TRANSLATIONS

The following French translations provided below are found in the Safety Section located at the beginning of the manual.

English	French
IMPORTANT SAFETY INSTRUCTIONS WARNING – To reduce the risk of injury or death:	INSTRUCTIONS DE SÉCURITÉ IMPORTANTES AVERTISSEMENT – Pour réduire les risques de blessures et de mort :
1. READ AND FOLLOW ALL INSTRUCTIONS.	1. LISEZ CETTE NOTICE ET CONFORMEZ-VOUS AUX MISES EN GARDE
2. Never let children operate or play with gate controls. Keep the remote control away from children.	2. Ne laissez jamais les enfants manoeuvrer les commandes de la barrière ou jouer avec celles-ci. Laissez la télécommande hors de la portée des enfants.
3. Always keep people and objects away from the gate. NO ONE SHOULD CROSS THE PATH OF THE MOVING GATE.	3. Tenez toujours à l'écart de la barrière toute personne ou tout objet avoisinant. IL NE FAUT JAMAIS PASSER DANS LA TRAJECTOIRE D'UNE BARRIÈRE EN MOUVEMENT.
4. Test the gate operator monthly. The gate MUST reverse on contact with a rigid object or stop when an object activates the non-contact sensors. After adjusting the force or the limit of travel, retest the gate operator. Failure to adjust and retest the gate operator properly can increase the risk of injury or death.	4. Vérifiez le fonctionnement de l'ouvre-barrière une fois par mois. Le sens de la course DOIT s'inverser lorsque la barrière entre en contact avec un objet dur ou la barrière DOIT s'arrêter lorsqu'un objet active les capteurs sans contact. Vérifiez à nouveau l'ouvre-barrière après tout réglage de la force de déclenchement ou du seuil de fin de course. Un réglage incorrect de l'ouvre-barrière ou l'omission de vérifier à nouveau le fonctionnement de l'ouvre-barrière peut causer des blessures, voire la mort.
5. Use the emergency release only when the gate is not moving.	5. Ne déclenchez le dispositif de désaccouplement d'urgence que lorsque la barrière ne bouge pas.
6. KEEP GATES PROPERLY MAINTAINED. Read the user's manual. Have a qualified service person make repairs to gate hardware.	6. ASSUREZ-VOUS QUE LA BARRIÈRE EST CORRECTEMENT ENTRETENUE. Lisez le manuel de l'utilisateur. Confiez la réparation du matériel de la barrière à un technicien qualifié.
7. The entrance is for vehicles only. Pedestrians must use separate entrance.	7. La voie d'accès est réservée aux véhicules seulement. Les piétons doivent utiliser une voie d'accès différente.
8. SAVE THESE INSTRUCTIONS.	8. CONSERVEZ CES INSTRUCTIONS.

APPENDIX A - FRENCH TRANSLATIONS

English	French
2.3 Install the gate operator only when:	2.3 N'installez l'ouvre-barrière que si :
a. The operator is appropriate for the construction of the gate and the usage Class of the gate,	a. l'ouvre-barrière est approprié pour la structure et la classe d'utilisation de la barrière;
b. All openings of a horizontal slide gate are guarded or screened from the bottom of the gate to a minimum of 1.83 m (6 ft) above the ground to prevent a 57.2 mm (2-1/4 inch) diameter sphere from passing through the openings anywhere in the gate, and in that portion of the adjacent fence that the gate covers in the open position,	toutes les ouvertures de la barrière coulissante sont protégées ou grillagées du bas de la porte jusqu'à un minimum de 1,83 m (6 pi) du sol si bien qu'une sphère de 57,2 mm (2 1/4 po) de diamètre ne peut passer par une ouverture au niveau de la barrière et de la portion de la clôture adjacente que la barrière couvre en position ouverte;
c. All exposed pinch points are eliminated or guarded, and	c. tous les points de pincement sont éliminés ou protégés;
d. Guarding is supplied for exposed rollers.	d. des protections sont fournies pour les galets exposés.
2.4 The operator is intended for installation only on gates used for vehicles. Pedestrians must be supplied with a separate access opening. The pedestrian access opening shall be designed to promote pedestrian usage. Locate the gate such that persons will not come in contact with the vehicular gate during the entire path of travel of the vehicular gate.	2.4 L'ouvre-barrière est destiné à n'être installé que sur des barrières utilisées pour les véhicules. Il faut fournir une autre voie d'accès aux piétons. La voie d'accès pour les piétons doit être conçue pour favoriser le passage des piétons. Placez la barrière de sorte que personne ne puisse entrer en contact avec la barrière pour les véhicules sur l'ensemble de sa trajectoire
2.5 The gate must be installed in a location so that enough clearance is supplied between the gate and adjacent structures when opening and closing to reduce the risk of entrapment. Swinging gates shall not open into public access areas.	c) Pour réduire les risques de coincement lors de l'ouverture et de la fermeture, la barrière doit être installée dans un endroit où la barrière et les structures avoisinantes sont suffisamment éloignées l'une de l'autre. Les barrières battantes ne doivent pas ouvrir dans une zone d'accès public.

APPENDIX A - FRENCH TRANSLATIONS

English	French
2.6 The gate must be properly installed and work freely in both directions prior to the installation of the gate operator. Do not over-tighten the operator clutch or pressure relief valve to compensate for a damaged gate.	2.6 La barrière doit être bien installée et fonctionner librement dans les deux directions avant d'entreprendre l'installation de l'ouvre-barrière. Ne serrez pas trop l'embrayage ou la soupape de surpression de l'ouvre-barrière pour compenser une barrière endommagée.
2.7 Controls intended for user activation must be located at least 1.83 m (6 ft) away from any moving part of the gate and where the user is prevented from reaching over, under, around or through the gate to operate the controls. Exception: Emergency access controls only accessible by authorized personnel (e.g. fire, police, EMS) may be placed at any location in the line-of-sight of the gate.	2.7 Les commandes destinées à l'activation par l'utilisateur doivent être situées à au moins 1,83 m (6 pi) des pièces mobiles de la barrière et à un endroit où l'utilisateur ne peut pas atteindre les commandes par le dessus, par le dessous, par les côtés et au travers de la barrière. Exception : Les commandes d'accès d'urgence accessibles au personnel autorisé seulement (p. ex. pompier, policier, SMU) peuvent être placées à tout endroit dans le champ de visibilité de la barrière.
2.8 The Stop and/or Reset button must be located in the line of-sight of the gate. Activation of the reset control shall not cause the operator to start.	2.8 Le bouton d'arrêt, le bouton de réenclenchement ou ces deux boutons doivent être situés dans le champ de visibilité de la barrière. L'activation des commandes de réenclenchement ne doit pas mettre en marche l'ouvrebarrière.
2.9 A minimum of two (2) WARNING SIGNS shall be installed, in the area of the gate. Each placard is to be visible by persons located on the side of the gate on which the placard is installed.	2.9 Au moins deux panneaux de mise en garde doivent être installés dans la zone de la barrière. Chaque étiquette doit être visible des personnes situées de chaque côté de la barrière sur laquelle l'étiquette est installée.
2.10 For gate operators utilizing a non-contact sensor	2.10 Pour les ouvre-barrières qui fonctionnent avec des capteurs
a. See instructions on the placement of non-contact sensors for each Type of application,	a. Voir les instructions sur le positionnement des capteurs sans contact pour chaque type d'utilisation.
b. Care shall be exercised to reduce the risk of nuisance tripping, such as when a vehicle, trips the sensor while the gate is still moving, and	b. Des précautions doivent être prises pour réduire les risques de déclenchement inutile, comme lorsqu'un véhicule déclenche le capteur alors que la barrière est encore en mouvement.
c. One or more non-contact sensors shall be located where the risk of entrapment or obstruction exists, such as the perimeter reachable by a moving gate or barrier.	c. Un capteur sans contact ou plus doit être situé où il existe un risque de coincement ou d'obstruction, comme dans l'espace que peut occuper la barrière lorsqu'elle est en mouvement.
2.11 For a gate operator utilizing a contact sensor	2.11 Pour les ouvre-barrières qui fonctionnent avec des capteurs

APPENDIX A - FRENCH TRANSLATIONS

English	French
<p>a. One or more contact sensors shall be located where the risk of entrapment or obstruction exists, such as at the leading edge, trailing edge, and postmounted both inside and outside of a vehicular horizontal slide gate.</p>	<p>a. Au moins un capteur de contact doit être situé où il existe un risque de coincement ou d'obstruction, comme sur le bord d'ouverture, sur le bord de fermeture et sur les poteaux montés sur l'intérieur ou l'extérieur d'une barrière coulissante pour véhicules.</p>
<p>b. A hardwired contact sensor shall be located and its wiring arranged so that the communication between the sensor and the gate operator is not subjected to mechanical damage.</p>	<p>b. Un capteur de contact doit être installé et câblé de sorte à éviter que la communication entre le capteur et l'ouvrebarrière soit gênée par des dommages mécaniques.</p>
<p>c. A wireless device such as one that transmits radio frequency (RF) signals to the gate operator for entrapment protection functions shall be located where the transmission of the signals are not obstructed or impeded by building structures, natural landscaping or similar obstruction. A wireless device shall function under the intended end-use conditions.</p>	<p>c. Un dispositif sans fil, comme un appareil qui transmet des signaux de radiofréquence (RF) à l'ouvre-barrière pour prévenir le coincement, doit être situé à un endroit où la transmission des signaux ne sera pas obstruée ou gênée par des structures, des arbres ou d'autres obstacles similaires. Un dispositif sans fil doit fonctionner selon les conditions d'utilisation finale prévues.</p>
<p>d. One or more contact sensors shall be located on the inside and outside leading edge of a swing gate. Additionally, if the bottom edge of a swing gate is greater than 152 mm (6 inches) but less than 406 mm (16 inches) above the ground at any point in its arc of travel, one or more contact sensors shall be located on the bottom edge.</p>	<p>d. Au moins un capteur de contact doit être situé sur les bords d'ouverture intérieur et extérieur d'une barrière battante. De plus, si le dessous d'une barrière battante est situé à plus de 152 mm (6 po) mais à moins de 406 mm (16 po) du sol à l'un des points de sa trajectoire, au moins un capteur de contact doit être situé sur le bord inférieur.</p>

(This page intentionally blank)

WARRANTY

1. Warranty.

HySecurity Gate, Inc. ("HySecurity") warrants that at the time of sale each HySecurity-branded product that it sells will, in all material respects, conform to its then applicable specification and will be free from defects in material and manufacture.

The following additional durational warranties apply to HySecurity products, depending on whether (1) the product is purchased through an authorized HySecurity distributor and (2) whether a timely and complete product registration is submitted to HySecurity.

It is therefore important that you register your product with HySecurity, online at www.hysecurity.com/warranty, within the 60-day period described below.

1(a) HySecurity Products Purchased Through Authorized Distributors and Properly Registered

For any gate operator product that is purchased from an authorized HySecurity distributor (this excludes product purchased through internet resellers or any distributor not authorized by HySecurity), if the product registration is completed by the Dealer/Installer or End User within 60 days of the date of purchase, the following warranty terms will apply. HySecurity warrants that the product will remain serviceable for the following periods:

- Hydraulic industrial gate operator hydraulics, controls, and mechanical components: Five Years or 500,000 gate cycles (whichever occurs first) after the date of installation,
- Hydraulic wedge operator hydraulics and controls: Five Years or 500,000 cycles (whichever occurs first) after the date of installation. Wedge mechanical components: Two Years after the date of installation,
- Electromechanical pad-mounted Slide and Swing operators: Five Years or 500,000 cycles (whichever occurs first) after the date of installation, except single family residential usage, where the warranty term shall be Seven Years after the date the product was shipped from HySecurity,
- Electromechanical linear actuator Swing operators: Two Years after the date of installation,
- Electromechanical surface mount wedge operator electronics: Two Years or 500,000 gate cycles (whichever occurs first), after the date of installation,
- Electromechanical Barrier Arm Operators: Two years or 1,000,000 gate cycles (whichever occurs first) after the date of installation,

provided that the preceding Five Year warranty period in (a), (b), and (c) will not extend beyond seven years from the date that the product was shipped from HySecurity, and the Two Year warranty period in (b), (d), (e), and (f) will not extend beyond four years from the date that the product was shipped from HySecurity.

The preceding warranty durations do not apply to the products or components described below (g-j), which have a shorter warranty period:

- Hydraulic gate operator drive wheels, including XtremeDrive™ wheels and rack: Two Years from date of installation.
- AC and DC power supplies, chargers, and inverters and HyNet™ Gateway: Two Years from date of installation, except batteries.
- Batteries: One Year from date of shipment from HySecurity.
- Components subject to normal wear including, but not limited to, chains, belts, idler wheels, sprockets and fuses: One Year from date of installation.

1(b) HySecurity Products Not Purchased Through an Authorized Distributor or Not Properly Registered within 60 Days

For any product that is not purchased from an authorized HySecurity distributor or for which the product registration was not completed by the Dealer/Installer/End User within sixty (60) days of the date of purchase, the following warranty will apply: HySecurity warrants that the product will remain serviceable for the following periods, which begin on the date that the product was shipped from HySecurity:

- All gate operators: One Year or 100,000 gate cycles, whichever comes first.
- AC and DC power supplies, chargers, or inverters: One Year.
- HyNet™ Gateway: One Year.
- Hydraulic gate operator drive wheels: One Year.

1(c) Replacement Parts

HySecurity warrants that replacement parts (whether new or reconditioned) will remain serviceable for One Year from the date that the part was shipped from HySecurity or the remaining period of the Gate Operator warranty, whichever is longer.

1(d) Limitations and Exclusions Applicable to Each of the Preceding Warranties.

The preceding warranties shall not apply to equipment that has been (1) installed, maintained, or used improperly or contrary to instructions; (2) subjected to negligence, accident, vandalism, or damaged by severe weather, wind, flood, fire,

terrorism or war; or (3) damaged through improper operation, maintenance, storage or abnormal or extraordinary use or abuse. Any modification made to products will void the warranty unless the modifications are approved in writing by HySecurity in advance of the change (this exclusion does not apply to normal installation of approved accessories and/or protective devices or sensors). It is the responsibility of the Distributor, Dealer/Installer, or End User to ensure that the software version in the product is maintained to the latest revision level.

The preceding warranties do not extend to accessories when those items carry another manufacturer's name plate and they are not a part of the base model. HySecurity disclaims all warranties for such accessory components, which carry only the original warranty, if any, of their original manufacturer. HySecurity hereby assigns its rights under such manufacturer warranties—to the extent that such rights are assignable—to Buyer.

These warranties extend to HySecurity's Distributors, to the Dealer/Installer, and to the first End User of the product following installation. They do not extend to subsequent purchasers.

2. Exclusion of Other Warranties.

The warranties contained in Section 1 are the exclusive warranties given by HySecurity and supersede any prior, contrary or additional representations, whether oral or written. Any prior or extrinsic representations or agreements are discharged or nullified. HYSECURITY HEREBY DISCLAIMS AND EXCLUDES ALL OTHER WARRANTIES—WHETHER EXPRESS, IMPLIED, OR STATUTORY—INCLUDING ANY WARRANTY OF MERCHANTABILITY, ANY WARRANTY OF FITNESS FOR A PARTICULAR PURPOSE, ANY LIABILITY FOR INFRINGEMENT, AND ANY WARRANTIES OTHERWISE ARISING FROM COURSE OF DEALING, COURSE OF PERFORMANCE, OR USAGE OF TRADE.

3. Buyer's Exclusive Remedies for Any Nonconformity.

If a HySecurity product fails to conform to the warranties in Section 1, Buyer must notify and order replacement parts from the Distributor through which the product was purchased within a reasonable time and in no event more than thirty (30) days after the discovery of the nonconformity. HySecurity will investigate and, in the event of a breach, will provide, within a reasonable period of time, one of the following:

- repair or replacement of any nonconforming products or components or
- refund of the price upon return of the nonconforming items. HySecurity reserves the right to supply used or reconditioned material for all warranty claims. HySecurity will not be considered to be in breach of or default under this Warranty because of any failure to perform due to conditions beyond its reasonable control, including any force majeure. This warranty does not cover any incidental expenses, including fines or penalties, temporary security, labor, shipping, travel time or standby time that are incurred for inspection or replacement of any nonconforming items. As a condition of warranty coverage, warranty claims must be submitted in accordance with the procedures described on the HySecurity form, "RMA Procedures."

THE REMEDY SELECTED BY HYSECURITY IN ACCORDANCE WITH THIS PARAGRAPH SHALL BE THE EXCLUSIVE AND SOLE REMEDY OF BUYER FOR ANY BREACH OF WARRANTY.

4. Exclusion of Consequential and Incidental Damages.

HYSECURITY SHALL NOT BE LIABLE FOR ANY INCIDENTAL, SPECIAL, OR CONSEQUENTIAL DAMAGES, WHETHER RESULTING FROM NONDELIVERY OR FROM THE USE, MISUSE, OR INABILITY TO USE THE PRODUCT OR FROM DEFECTS IN THE PRODUCT OR FROM HYSECURITY'S OWN NEGLIGENCE. This exclusion applies regardless of whether such damages are sought for breach of warranty, breach of contract, negligence, or strict liability. This exclusion does not apply to claims for bodily injury or death.

5. Severability.

If any provision of this warranty is found to be invalid or unenforceable, then the remainder shall have full force and effect.

6. Proprietary Rights.

HySecurity retains and reserves all right, title, and interest in the intellectual property rights of its products, including any accompanying proprietary software. No ownership of any intellectual property rights in the products or accompanying software is transferred to Distributor, Dealer/Installer, or End User.

7. Applicable Law.

This warranty will be interpreted, construed, and enforced in all respects in accordance with the laws of the State of Washington, without reference to its choice of law principles. The U.N. Convention on Contracts for the International Sale of Goods will not apply to this warranty.

(This page intentionally blank)

8 HydraLift™ Models

	FAST Operators			
	Standard	Heavy Duty	Standard Fast	Heavy Duty Fast
Model	HydraLift 10	HydraLift 20	Hydralift 10F	HydraLift 20F
Part#	HVG 420 ST	HVG 460 ST	HVG 420 EX ST	HVG 460 EX ST
Duty Cycle	Continuous			
Horsepower	2 hp		5 hp	
Drive	Hydraulic			
Gate Weight Max.	1,000 lb (453 kg)	2,000 lb (907 kg)	1,000 lb (453 kg)	2,000 lb (907 kg)
Gate Length Max.	50 ft (15 m)	80 ft (24 m)	50 ft (15 m)	80 ft (24 m)
Rate of Travel	1 ft/s (30 cm/s)		2 ft/s (60 cm/s)	
Temperature Rating	-40° F to 158° F (-40° C to 70° C)			
1 Phase Power**	208/230V 60Hz, 220V 50Hz		230V 60Hz	
3 Phase Power**	208/230/460V 60Hz; 220/380V 50Hz		208/230/460V 60Hz; 220/380V 50Hz	
Communication	RS-232, RS-485, Ethernet/fiber using optional HyNet™ Gateway accessory			
User Controls	Smart Touch Controller with 70+ configurable settings. Smart Touch keypad and display or a PC using S.T.A.R.T. software.			
Relays	Three configurable user relays: one 30VDC, 3A solid state and two 250VAC, 10A electromechanical; Optional Hy8Relay™ for 8 additional output relays			
Finish	Hot dipped galvanized lifting posts			
Enclosure	HydraSupply: Type 3R, 30w x 42h X 12d inch (76w x 107h x 30.5d cm)			
ETL Listed (UL 325)	Usage Class I, II, III, IV		Usage Class III, IV	
Warranty	5 year w/product registration			

UPS Battery Backup Power*

DC Power Supply*†	HydraLift 10 UPS	HydraLift 20 UPS	HydraLift 10F UPS	HydraLift 20F UPS

* HydraLift 10, 20: 1,500 cycles/day expected duty cycle. HydraLift 10F, 20F: 1,000 cycles/day expected duty cycle. The operator's normal duty cycle and the actual number of gate cycles available from battery depends upon gate resistance to travel, cycle length, battery size, state of charge and health, ambient temperature, accessory power draw and frequency of gate cycles during power outage.

** Refer to Installed Options on pricing for all 50Hz voltages, which are special order.

† 115V DC Power Supply requires a 30A branch circuit. Choose voltage with care as chargers are not field convertible.

This gate operator requires an external entrapment protection sensor to monitor the close direction of travel. Visit hysecurity.com/gatesafety for more information on UL 325 standards and gate safety.

Contact Information:

Visit <https://hysecurity.com/technical-support/> for installation manuals, replacement part instructions, part diagrams and more.

Qualified HySecurity distributors are experienced and trained to assist in resolving installation problems. For the name of a qualified distributor near you, call HySecurity at 800-321-9947. *Before contacting your distributor or HySecurity Technical Support, obtain the serial number of your operator.