

REMOVAL OF EXISTING PARTS

1. Disconnect power to operator.
2. Remove the master link from the drive chain and unwrap chain from idler sprockets and pull out of chain guides.
3. Disconnect radio antenna and cable from guard and set aside for reinstallation.
4. Remove chain guard and discard.

INSTALLATION OF NEW PARTS

1. Install new guard with hardware provided.
2. Reinstall antenna and cable.
3. Reinstall existing chain.
4. Reconnect power to operator.

⚠️ WARNING

To prevent possible **SERIOUS INJURY** or **DEATH**, disconnect electric power to operator **BEFORE** installing. **ALL** electrical connections **MUST** be made by a qualified individual.

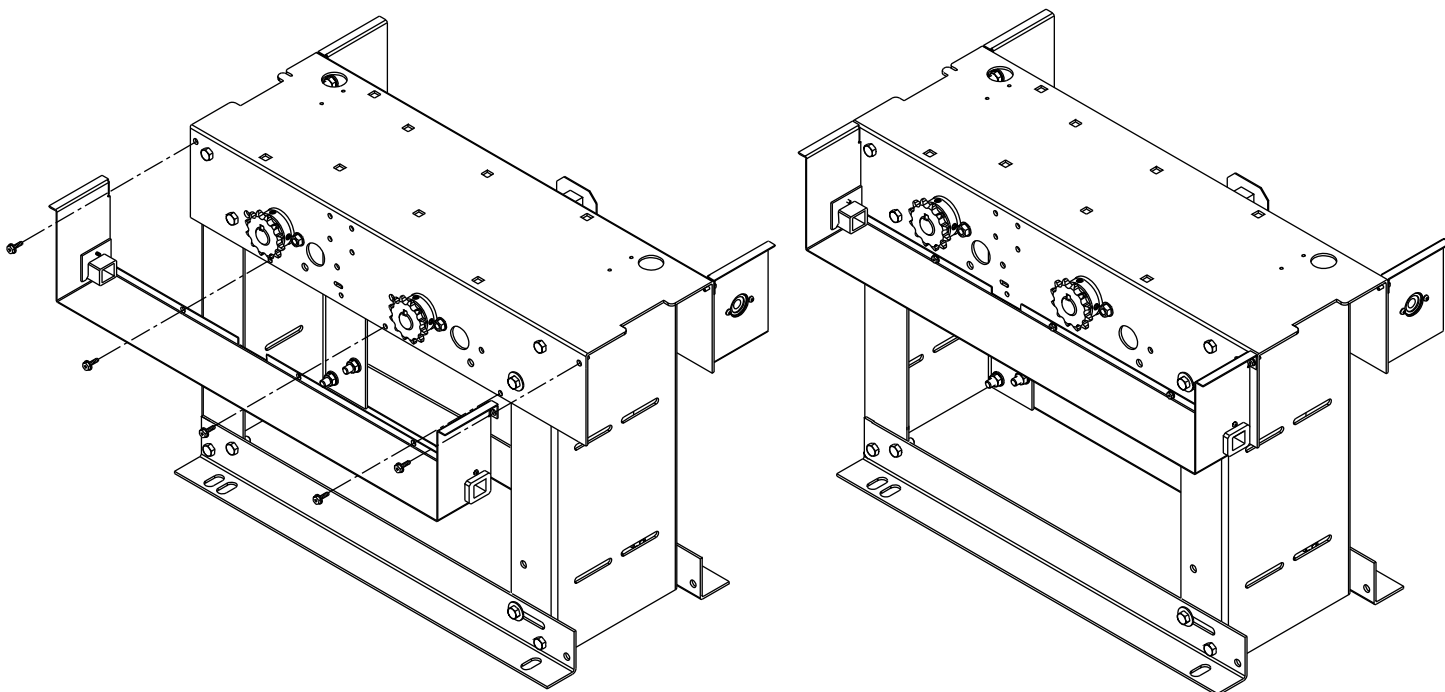

NOTE: Other components not shown for ease of viewing.