



# INSTALLATION INSTRUCTIONS AND SAFETY INFORMATION

FOR THE VIKING K-2S GATE OPERATOR



CLASS I  
**Solar Residential Vehicular  
Slide Gate Operator**





The K-2S™ Viking Solar Gate Operator has the capacity to operate slide gates up to 700 lbs. and 30 ft. long under extreme conditions. This efficient operator provides a solution for residential slide gate solar applications thanks to its efficient electromechanical design. Equipped with latest solar innovations, the K-2S™ is the most energy efficient slide gate operator offered on the market.

## THE VIKING K-2S™ SOLAR SLIDE GATE OPERATOR

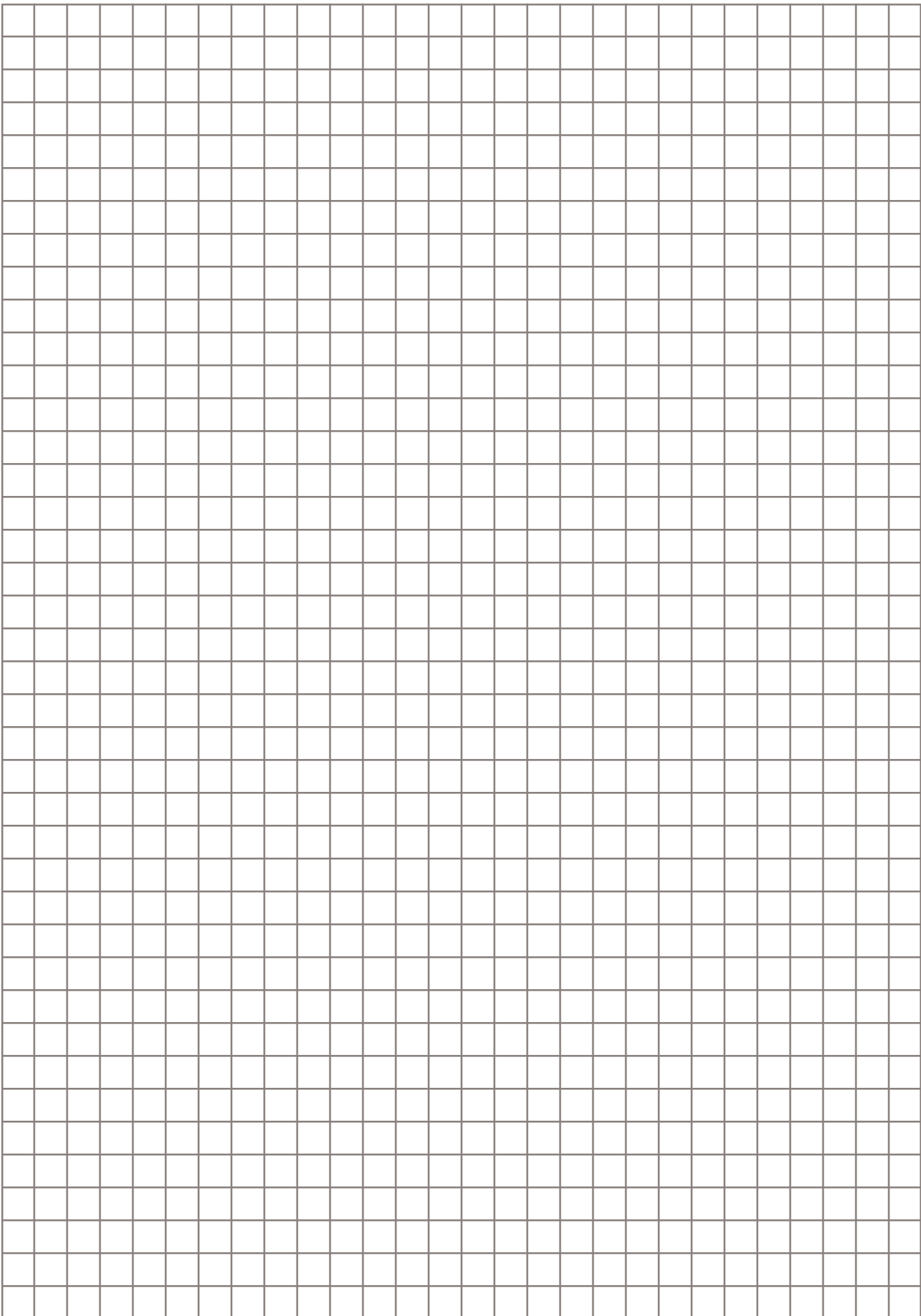

# PARTS DIAGRAM:

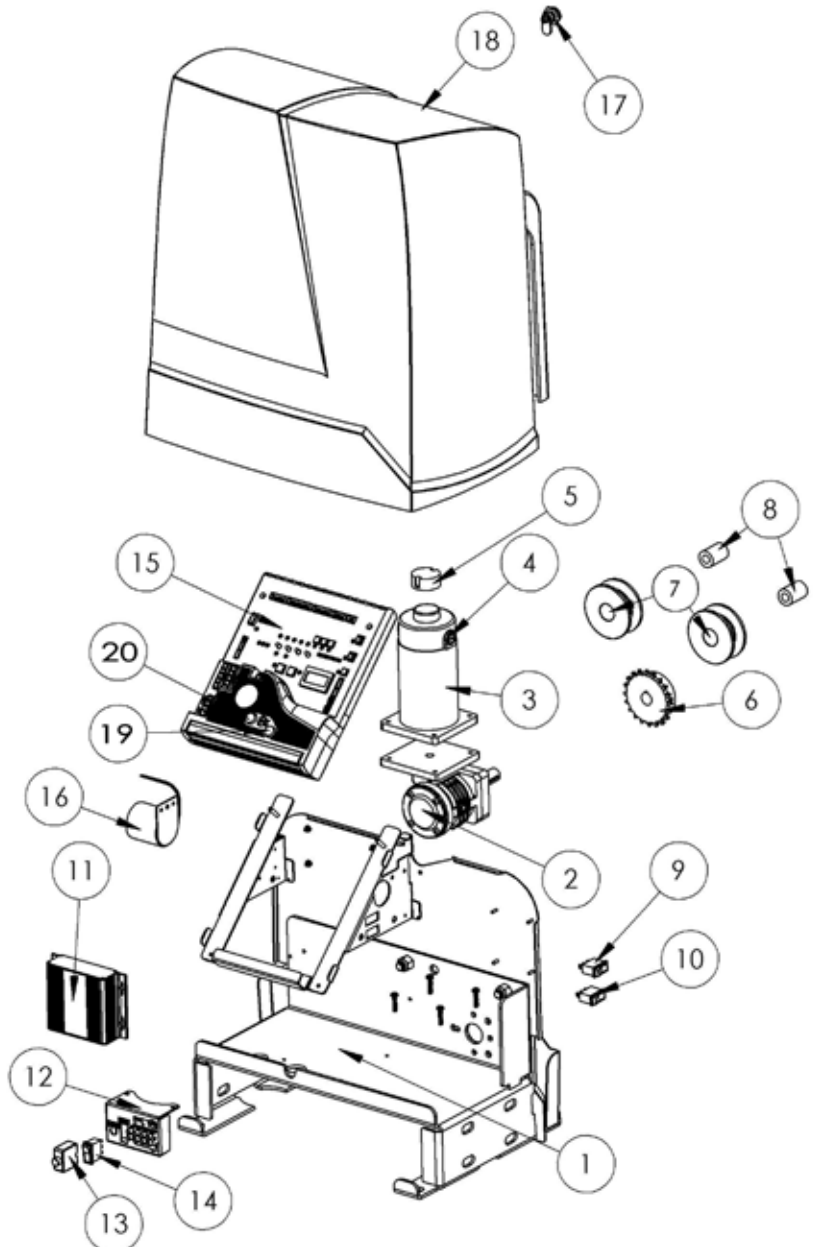
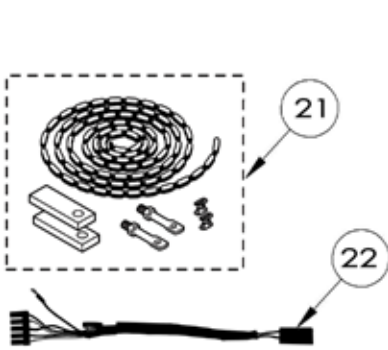

Item	Description	Part No.
1	Chassis	VSK2CH
2	Gearbox	VNXK2GB
3	Motor	VSK2MO
4	Brush Kit	VAMBK
5	Electronic Positioning Sensor 2 (EPS2)	VNXSLEPS2
6	Sprocket	VAL3SP17
7	Idler Pulley	DSIP10
8	Idler Bushing	DSIB10
9	Manual Release Switch	DUMRS10
10	Power Switch	DUMRS10
11	Solar Charger	VSCHARGSL
12	Solar Terminal Block Assembly	VSTBASL
13	Solar Battery Breaker	VASBB25
14	Solar Panel Switch	DUMRS5
15	Solar Control Board	VSPCBUI8
16	Alarm	DUAL10
17	Lock Cylinder & Key(s)	VNXSLCL
18	Operator Cover	VNXK2CV
19	Fuse - 4 amp	VNXF4A
20	Fuse - 15 amp	VNXF15A
21	25' #40 Chain Kit, Nickel Coated	VAL3CKN
22	Motor Harness	VNXK2MH

### Overall Dimensions

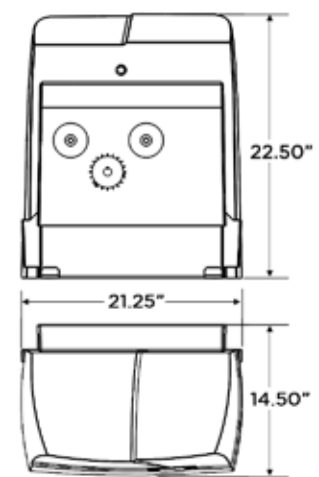

Weight - 75 lbs.

# OPERATOR REFERENCES:

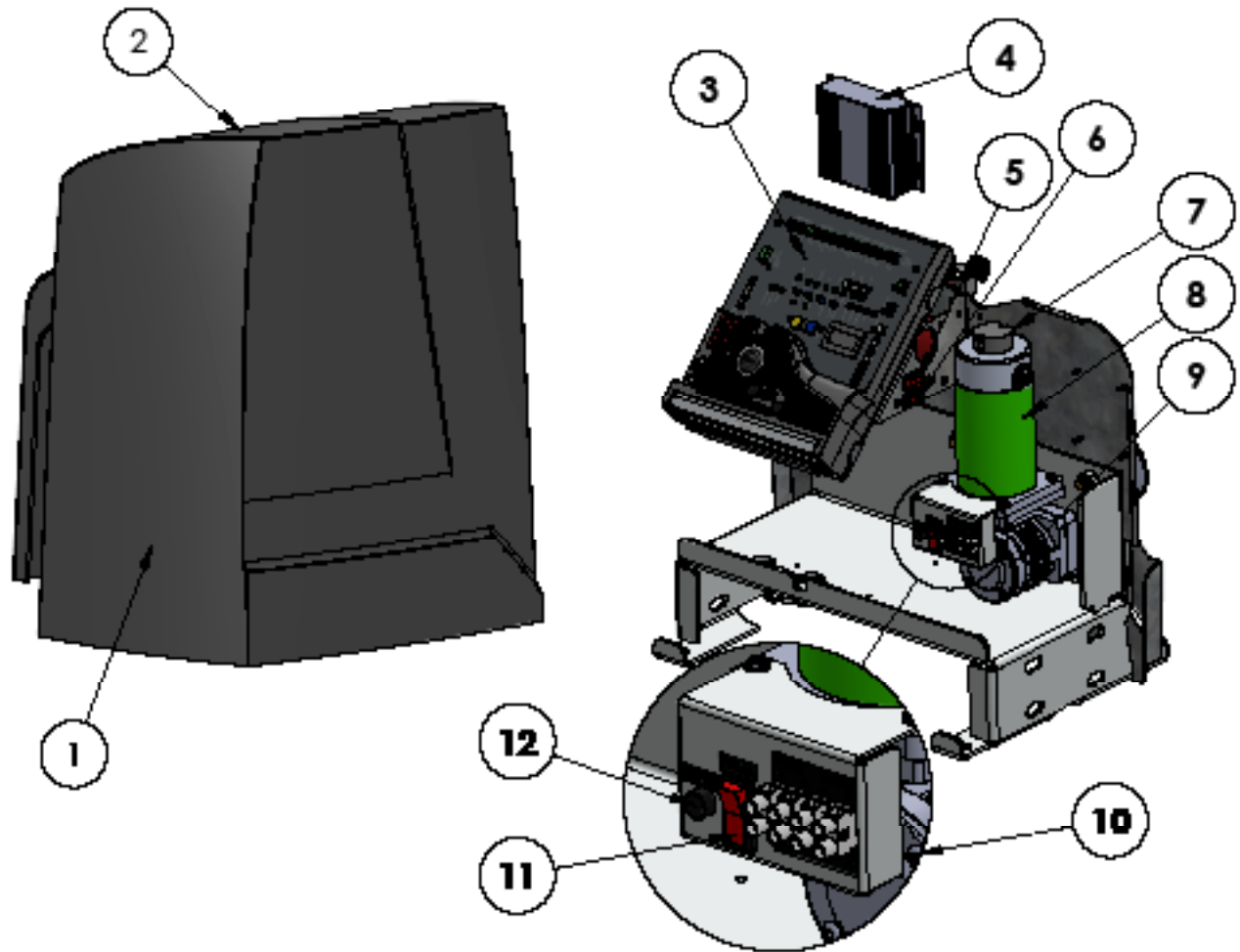

1. OPERATOR COVER
2. COVER LOCK
3. SOLAR CONTROL BOARD
4. SOLAR CHARGER  
regulates and distributes solar power
5. MANUAL RELEASE/MOTOR SWITCH  
discontinues power to the motor and allows for manual operation of the gate
6. POWER SWITCH  
discontinues all power to the control board
7. EPS (ELECTRONIC POSITIONING SENSOR)  
sensor for the digital limits
8. MOTOR
9. GEAR BOX
10. SOLAR TERMINAL BLOCK ASSEMBLY  
connections for solar panels and battery
11. SOLAR PANEL SWITCH/BREAKER  
discontinues power from the solar panels to the Solar Charger
12. BATTERY BREAKER  
resettable breaker protects the battery circuit

# CONTROL BOARD REFERENCES:

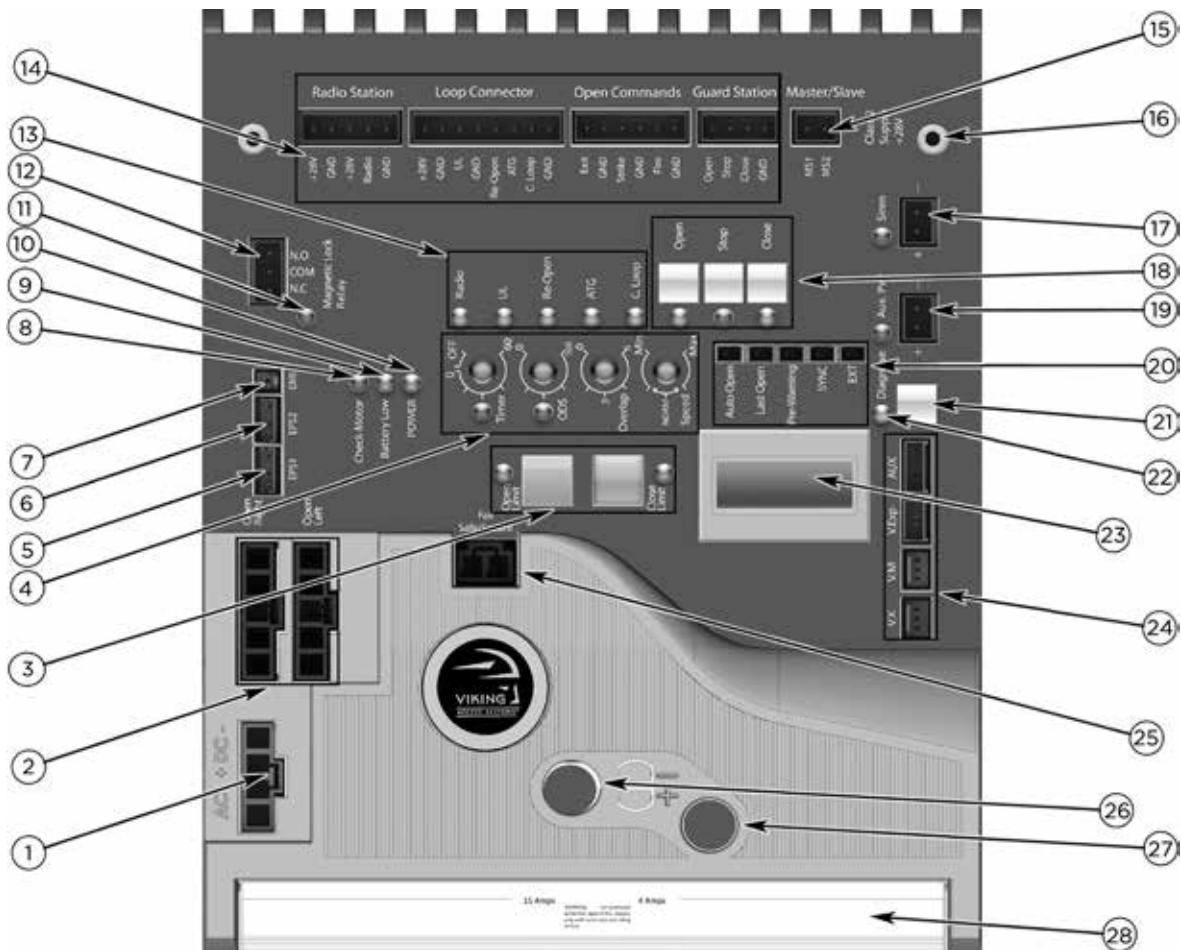

- |   |   |   |
|---|---|---|
| <p>1. POWER HARNESS CONNECTOR provides power to the control board. pg 20</p> <p>2. "OPEN LEFT" &amp; "OPEN RIGHT" provides power to the motor. pg 21</p> <p>3. LIMIT SETUP BUTTONS sets limit positions. pg 21-22</p> <p>4. FEATURE ACTIVATION TRIM POTS activate and set features. pg 24</p> <p>5. "EPS1" CONNECTOR communication for Viking Solar Charger.</p> <p>6. "EPS2" CONNECTOR monitors the limit positions.</p> <p>7. "EMI" CONNECTOR not applicable to this model.</p> <p>8. "CHECK MOTOR" Status LED indicates motor power status. pg 36</p> <p>9. "BATTERY LOW" Status LED indicates battery power status. pg 36</p> <p>10. "POWER" Status LED control board power status. pg 36</p> | <p>11. "MAGNETIC LOCK RELAY" Status LED status of this on-board relay. pg 36</p> <p>12. "MAGNETIC LOCK RELAY" Terminal Block connect electric locks here. pg 36</p> <p>13. INPUT STATUS LEDs indicates input status. pg 36-37</p> <p>14. ACCESS CONTROL TERMINAL BLOCKS accessory connections. pg 29-32, 42-44</p> <p>15. "MASTER/SLAVE" Terminal Block wired master/slave connection. pg 23</p> <p>16. CONTROL BOARD MOUNTING HOLES secures and grounds the control board.</p> <p>17. "Siren" TERMINAL BLOCK Vikings UL Siren is connected here.</p> <p>18. ON-BOARD 3 BUTTON STATION controls the gate during set up.</p> <p>19. "AUX. PWR" Terminal Block used for solar applications &amp; in-motion warning devices. pg 20, 25</p> <p>20. FEATURE ACTIVATION PIN HEADERS activate features by placing a jumper onto the pin headers. pg 25</p> | <p>21. "DIAGNOSE" Button allows you to navigate through the Diagnostics LCD Display. pg 38-40</p> <p>22. "DIAGNOSE" LED informs that errors have been detected and available on LCD Display. pg 38-40</p> <p>23. LCD DIAGNOSTICS DISPLAY provides error messages, diagnostics and operator status information. pg 38-40</p> <p>24. EXPANSION PRODUCT CONNECTIONS connections for additional products from Viking Access Systems. pg 46</p> <p>25. "FAIL SAFE/SECURE" Jumper power failure option. pg 25</p> <p>26. FUSE HOLDER - 15 AMP for motor circuit.</p> <p>27. FUSE HOLDER - 4 AMP not applicable to this model.</p> <p>28. HEAT SINK secures the control board and dissipates heat.</p> |
|---|---|---|

# TABLE OF CONTENTS:

<b>PARTS DIAGRAM/PARTS LIST</b>	<b>2</b>
<b>OPERATOR REFERENCES</b>	<b>3</b>
<b>CONTROL BOARD REFERENCES</b>	<b>4</b>
<b>IMPORTANT SAFETY INFORMATION</b>	<b>6-12</b>
Important Safety Instructions.....	6
Important Installation Instructions.....	7
Maintenance.....	8
General Safety Precautions.....	8-9
Operator Classification.....	9
Entrapment Protection Requirements.....	10
Entrapment Protection Installation.....	11
Manual Release.....	11
Audible Alarm Reset Installation.....	12
Warning Placard Installation.....	12
<b>IMPORTANT INSTALLATION INFORMATION</b>	<b>13</b>
Specifications.....	13
<b>GATE OPERATOR INSTALLATION</b>	<b>14-17</b>
Concrete Pad Option.....	14
Post Mounting Option.....	15
Operator Positioning.....	16-17
<b>ELECTRICAL INSTALLATION</b>	<b>18-20</b>
Battery & Solar Panel Selection.....	18
Solar Panel Care & Installation Tips.....	19
Solar Connection & Power Saving Tips.....	20
<b>LIMITS SETUP</b>	<b>21-22</b>
<b>MASTER/SLAVE SET UP</b>	<b>23</b>
<b>CONTROL BOARD SETUP</b>	<b>24-26</b>
Initial Settings.....	24-25
Obstruction Detection Sensor (ODS).....	26
<b>ACCESSORY CONNECTIONS</b>	<b>28-35</b>
UL, Re-Open (Monitored Input Terminals).....	28-29
Radio Receiver (Typical).....	30
Anti-Tail Gate, Open Commands, Guard Station.....	31
Viking Loop Rack.....	32
Guidelines for Loop Installations.....	33
Blank Page.....	34
Barrier Arm Synchronization.....	35
<b>TROUBLESHOOTING</b>	<b>36-41</b>
LED References.....	36-37
LCD Display References.....	38-40
Solutions.....	41
<b>APPENDIX A, B</b>	<b>42-44</b>
<b>VIKING EXPANSION PRODUCTS</b>	<b>46</b>

# IMPORTANT SAFETY INFORMATION

 **WARNING! Not Following these instructions may cause severe injury or death.**

## IMPORTANT SAFETY INSTRUCTIONS

 **WARNING! To reduce the risk of severe injury or death.**

1. READ AND FOLLOW ALL INSTRUCTIONS.
2. Never let children operate or play with gate controls. Keep the remote away from children.
3. Always keep people and objects away from the gate. **NO ONE SHOULD CROSS THE PATH OF THE MOVING GATE.**
4. Test the gate operator monthly. The gate **MUST** reverse on contact with a rigid object or when an object activates the non-contact sensors. After adjusting the force or the limit travel, retest the gate operator. Failure to adjust and retest the gate operator properly can increase the risk of injury or death.
5. Use the emergency release only when the gate is not moving.
6. **KEEP GATES PROPERLY MAINTAINED.** Read the user's manual. Have a qualified service person make repairs to gate hardware.
7. The entrance is for vehicles only. Pedestrians must use a separate entrance.
8. **Every gate operator installation MUST have secondary protection devices against entrapment, such as edge sensors and photo beams more in particularly in places where the risk of entrapment is more likely to occur.**
9. SAVE THESE INSTRUCTIONS.

## IMPORTANT INSTALLATION INSTRUCTIONS

1. Install the gate operator only when:
  - a. The operator is appropriate for the construction of the gate and usage Class of the gate (refer to page 9),
  - b. All openings of a horizontal slide gate are guarded or screened from the bottom of the gate to a minimum of 6 feet (1.83 m) above the ground to prevent a 2-1/4 inch (57.2 mm) diameter sphere from passing through the openings anywhere in the gate, and in that portion of the adjacent fence that the gate covers in the open position,
  - c. **ALL EXPOSED PINCH POINTS ARE ELIMINATED OR GUARDED, AND**
  - d. **GUARDING IS SUPPLIED FOR EXPOSED ROLLERS.**
2. The Operator is intended for installation only on gates used for vehicles. Pedestrians must be supplied with a separate access opening. The pedestrian access opening shall be designed to promote pedestrian usage. Locate the gate such that persons will not come into contact with the vehicular gate during the entire path of travel of the vehicular gate.
3. The gate must be installed in a location so that enough clearance is supplied between the gate and adjacent structures when opening and closing to reduce the risk of entrapment. Swinging gates shall not open in to the public access areas.
4. The gate must be properly installed and work freely in both directions prior to the installation of the gate operator. Do not over-tighten the operator clutch or pressure relief valve to compensate for a damaged gate.
5. The gate operator controls must be placed so that the user has full view of the gate area when the gate is moving **AND AWAY FROM THE GATE PATH PERIMETER.**
6. Controls intended for user activation must be located at least six feet (6') away from any moving part of the gate and where the user is prevented from reaching over, under, around or through the gate to operate the controls.

*Exception:* Emergency access controls only accessible by authorized personnel (i.e. fire, police, EMS) may be placed at any location in the line-of-sight of the gate.



# IMPORTANT SAFETY INFORMATION

**⚠ WARNING! Not Following these instructions may cause severe injury or death.**

## IMPORTANT INSTALLATION INSTRUCTIONS (Continued)

7. The Stop and/or Reset button must be located in the line-of-sight of the gate. Activation of the reset control shall not cause the operator to start.
8. A minimum of two (2) WARNING SIGNS shall be installed, in the area of the gate. Each placard is to be visible by persons located on the side of the gate on which the placard is installed.
9. **For gate operators using non-contact sensors (photoelectric beam or like) in accordance with section 32.1.1 of the UL standard:**
  - a. See instructions on the placement of non-contact sensors for each type of application (refer to page 10).
  - b. Care shall be exercised to reduce the risk of nuisance tripping, such as when a vehicle, trips the sensor while the gate is still moving, and
  - c. One or more non-contact sensors shall be located where the risk of entrapment or obstruction exists, such as the perimeter reachable by a moving gate or barrier (refer to page 10).
  - d. For UL compliance: Use only Omron: E3K-R10K4-NR-1 // EMX: IRB-RET, IRB-MON // Miller Edge: RG-K-R, PG-K-R100, PG-K-R50, MIM-62  
For ETL compliance: Use only Seco-Larm E-931-33PRGQ, E-936-S45RRGQ, E-931-S5ORRGQ, E-960-D90GQ // EMX NIR-50-325
10. **For a gate operator utilizing a contact sensor (edge sensor or like) in accordance with section 32.1.1 of the UL 325 standard:**
  - a. One or more contact sensors shall be located where the risk of entrapment or obstruction exists, such as a the leading edge, trailing edge, and post mounted both inside and outside of a vehicular horizontal slide gate (refer to page 10).
  - b. One or more contact sensors shall be located at the bottom of a vehicular vertical lift gate.
  - c. One or more contact sensors shall be located at the pinch point of a vehicular vertical pivot gate.
  - d. A hardwired contact sensor shall be located and its wiring arranged so that the communication between the sensor and the gate operator is not subject to mechanical damage.
  - e. A wireless contact sensor such as one that transmits radio frequency (RF) signals to the gate operator for entrapment protection functions shall be located where the transmission of the signals are not obstructed or impeded by building structures, natural landscaping or similar obstructions. A wireless contact sensor shall function under the intended end-use conditions.
  - f. One or more contact sensors shall be located on the inside and outside leading edge of a swing gate. Additionally, if the bottom edge of a swing gate is greater than 6 inches (152 mm) but less than 16 inches (406 mm) above the ground at any point in its arc of travel, one or more contact sensors shall be located on the bottom edge.
  - g. One or more contact sensors shall be located at the bottom edge of a vertical barrier (arm).
  - h. For UL compliance: Use only EMX: WEL-200K // Miller Edge: ME110 through ME117, ME120, ME123, MG020, MGR20, MGS20, RB-G-K10, MIM-62 // ASO: 25.30, 25.45, 95.20

# IMPORTANT SAFETY INFORMATION

 **WARNING! Not Following these instructions may cause severe injury or death.**

## MAINTENANCE

Remove the Power Harness from the Control Board. (refer to page 20)

- Clean and lubricate the gate track wheels using the recommended lubricant.
- Inspect the track for any signs of cracking or separation.
- Check that all mounting hardware of the gate operator is properly tighten.
- Ensure that the gate moves freely.
- Check for corroded parts and replace if necessary.
- Check the battery for the following:
  - Battery connections must be free of corrosion.
  - Battery voltage must be 13VDC (fully charged battery).

Reconnect the Power Harness for the Control Board. (refer to page 20)

- Check and confirm the proper operation of all safety devices (photoelectric eye, edge sensors or like).
- Check and confirm the operation of all installed accessories.
- Check and confirm the operation of all special features such as the Intelligent Obstruction Sensor, Hold Open Timer. (refer to page 24 and 26)
- Check and confirm the operation of the manual release. (refer to page 7)

## GENERAL SAFETY PRECAUTIONS

The following precautions are an integral and essential part of the product and must be supplied to the user. Read them carefully as they contain important indications for the safe installation, use and maintenance.

- These instruction must be kept and forwarded to all possible future users of the system.
- This product must be used only for that which it has been expressly designed.
- Any other use is to be considered improper and therefore dangerous.
- The manufacturer cannot be held responsible for possible damage caused by improper, erroneous or unreasonable use.
- Avoid operating in the proximity of the hinges or moving mechanical parts.
- Do not enter the path of the moving gate while in motion.
- Do not obstruct the motion of the gate as this may cause a situation of danger.
- Do not allow children to play or stay within the path of the moving gate.
- Keep remote control or any other control devices out of the reach of children, in order to avoid possible involuntary activation of the gate operator.
- In case of break down or malfunctioning of the product, disconnect from the main power source. Do not attempt to repair or intervene directly, contact only qualified personnel for repair.
- Failure to comply with the above may create a situation of danger.
- All cleaning, maintenance or repair work must be carried out by qualified personnel.
- In order to guarantee that the system works efficiently and correctly it is important to have the manufacturer's instructions on maintenance of the gate and operator carried out by qualified personnel.
- In particular, regular checks are recommended in order to verify that the safety devices are operating correctly.

**All installation, maintenance and repair work must be documented and made available to the user.**

# IMPORTANT SAFETY INFORMATION

**⚠ CAUTION: To Reduce the Risk of Fire or Injury to Persons:**

## UL325 Gate Operator Classifications

### GLOSSARY

#### RESIDENTIAL VEHICULAR GATE OPERATOR

**CLASS I** - A vehicular gate operator (or system) intended for use in garages or parking areas associated with a residence of one-to four single families.

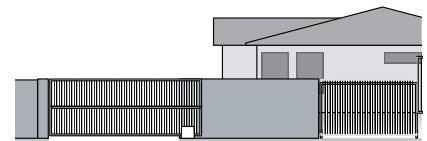

#### COMMERCIAL/GENERAL ACCESS VEHICULAR GATE OPERATOR

**CLASS II** - A vehicular gate operator (or system) intended for use in a commercial location or building such as a multi-family housing unit (five or more single family units), hotel, garages, retail store, or other building servicing the general public.

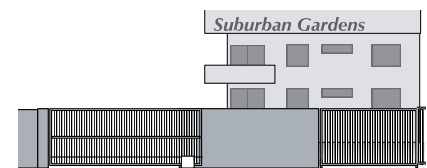

#### INDUSTRIAL/LIMITED ACCESS VEHICULAR GATE OPERATOR

**CLASS III** - A vehicular gate operator (or system) intended for use in an industrial location or building such as a factory or loading dock area or other locations not accessible by or intended to service the general public.

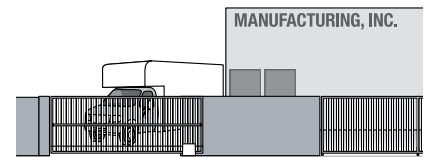

#### RESTRICTED ACCESS VEHICULAR GATE OPERATOR

**CLASS IV** - A vehicular gate operator (or system) intended for use in a guarded industrial location or building such as an airport security area or other restricted access locations not servicing the general public, in which unauthorized access is prevented via supervision by security personnel.

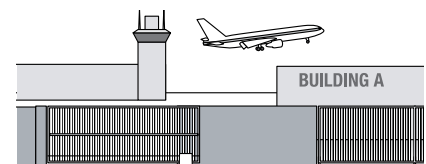

#### Install the gate operator only when:

The operator is appropriate for the construction of the gate and the Usage Class of the gate.

# IMPORTANT SAFETY INFORMATION

**⚠ WARNING! Not Following these instructions may cause severe injury or death.**

## Monitored Entrapment Protection Requirements

### IMPORTANT: MONITORED PROTECTION MUST BE INSTALLED

- **REQUIRED BY UL 325, an approved MONITORED entrapment protection sensor is REQUIRED to be installed in all areas accessible to potential entrapment and pinch points.**
- For Slide Gate Operators, a minimum of two monitored entrapment sensors are required to be connected as follows: Either one to the UL terminal and one connected to the Re-Open terminal, OR two monitored devices connected to the UL terminal, one for **EACH DIRECTION** of travel.
- **⚠ An external sensor connected to the “Re-Open” input terminal will protect against entrapment ONLY in the closing direction.**
- The installed sensor **MUST** be “**10K Resistor Based**”.
- You may connect up to **FOUR** monitored sensors, wired in parallel, to either the “UL” and/or “ReOpen” terminals, for a total of 8 monitored sensors.
- **Failure to install the required monitored entrapment protection sensor(s) may render the gate operator INOPERABLE. The gate can be moved manually. Refer to page 11.**
- Consult the installation manual of the sensor for detailed information about the usage, installation and maintenance.
- Use only UL Recognized Component Edge Sensors and Photoelectric Sensors. Refer to pg 7.

**SLIDE GATE ENTRAPMENT ZONE** – Locations between a moving gate and a counter opposing edge or surface where entrapment is possible up to 1.8 m (6 ft) above grade. Such locations occur if during any point in travel the gap between a moving gate and fixed counter opposing edges or surfaces is less than 406 mm (16 in).

### Photoelectric Sensor (non-contact sensor)

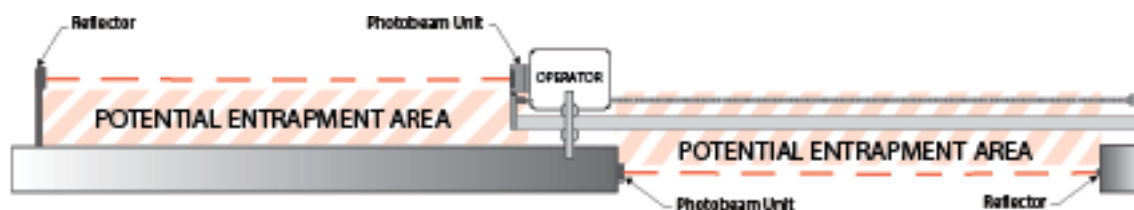

### Edge Sensor (contact sensor)

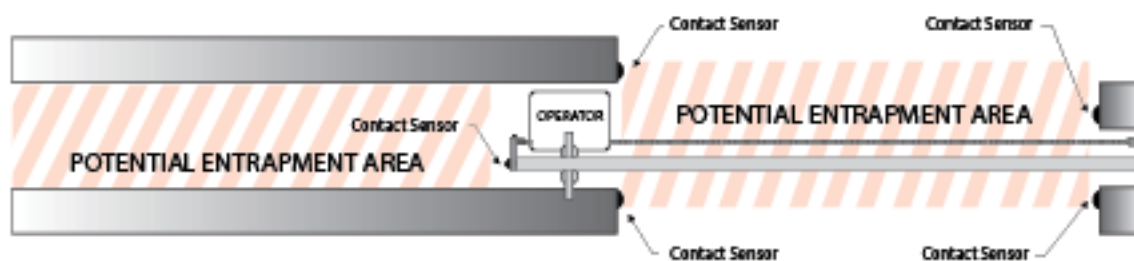

# IMPORTANT SAFETY INFORMATION

**⚠ WARNING! Not Following these instructions may cause severe injury or death.**  
**⚠ Cable use in Class 2 circuit to an external device shall be type CL2, CL2P, CL2R, CL2X or other cable with equivalent or better electrical, mechanical, and flammability ratings.**

## Monitored Entrapment Protection Installation

**⚠ IMPORTANT:** A minimum of two Monitored External Entrapment Sensors are required to be connected as follows: One to the UL terminal and one connected to the Re-Open terminal, OR two sensors connected to the UL terminal, one for **EACH DIRECTION** of travel.

**“UL”** Protects against entrapment in both the opening and closing directions. Input will reverse the gate momentarily in the opposite direction it was traveling. Refer to page 28.

**“Re-Open”** Protects against entrapment in the closing direction ONLY. Input will reverse the gate all the way to the Open Limit. Refer to page 29.

**STEP 1:** Connect the monitored entrapment protection sensor(s) to the Viking control board as illustrated.

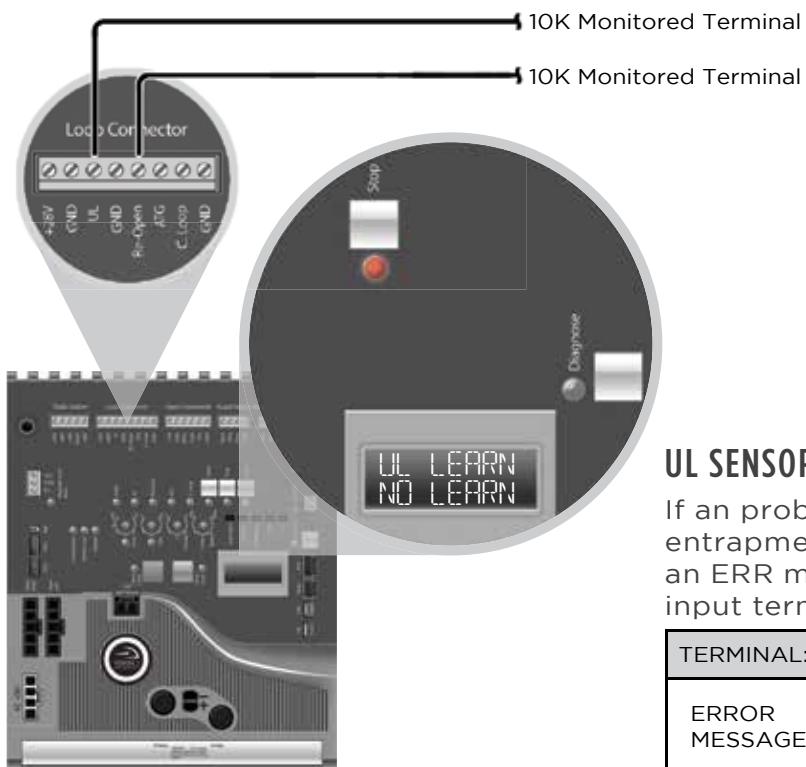

**STEP 2:**

**Execute the Learn Process:**

- Toggle the “Diagnose” button until you see UL LEARN NO LEARN on the LCD Display.
- Press and hold the “Stop” button.
- Toggle the “Diagnose” button once.
- The number of Monitored sensors connected to the “UL” or Re-Open terminals will now be displayed.

EXAMPLE: UL LEARN  
 UL2 RO1

### UL SENSOR ERRORS:

If an problem occurs with one of the monitored entrapment sensors, the “Stop” LED will flash and an ERR message will be displayed, indicating which input terminal(s) the sensor is connected to.

TERMINAL:	“UL”	“Re-Open”	“UL” & “Re-Open”
ERROR MESSAGE:	ERR SENS UL	ERR SENS RO	ERR SENS UL RO

## Manual Release

When manual operation is required:

1. Remove the operator cover
2. Press the Manual Release Switch (top) to the “RELEASE” Position.

**The gate can now be moved manually. To resume normal operation, press the switch to the “ENGAGE” position.**

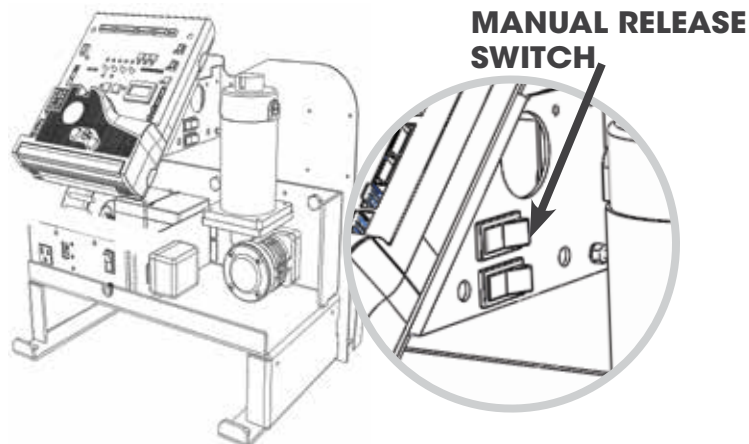

# IMPORTANT SAFETY INFORMATION

**⚠ WARNING! Not Following these instructions may cause severe injury or death.**

## Audible Alarm Reset Switch Installation

### Manual Reset for the Audible Alarm

- UL325 standard requires an audible alarm to sound after two consecutive events detected by the inherent entrapment protection of the gate operator (obstruction sensor).
- The audible alarm will continue to sound for 5 minutes or until a stop command gets actuated.
- The Stop command can be actuated in two different forms:
  1. Using the Built in Stop switch on the Control Board or;
  2. Using an External Stop button within the sight of the gate, away from moving parts of the gate and out of reach of children.
    - a. Controls intended for user activation must be located at least six feet (6') away from any moving part of the gate and where the user is prevented from reaching over, under, around or through the gate to operate the controls. Outdoor or easily accessible controls shall have a security feature to prevent unauthorized use.
    - b. The Stop and/or Reset button must be located in the line-of-sight of the gate. Activation of the reset control shall not cause the operator to start.

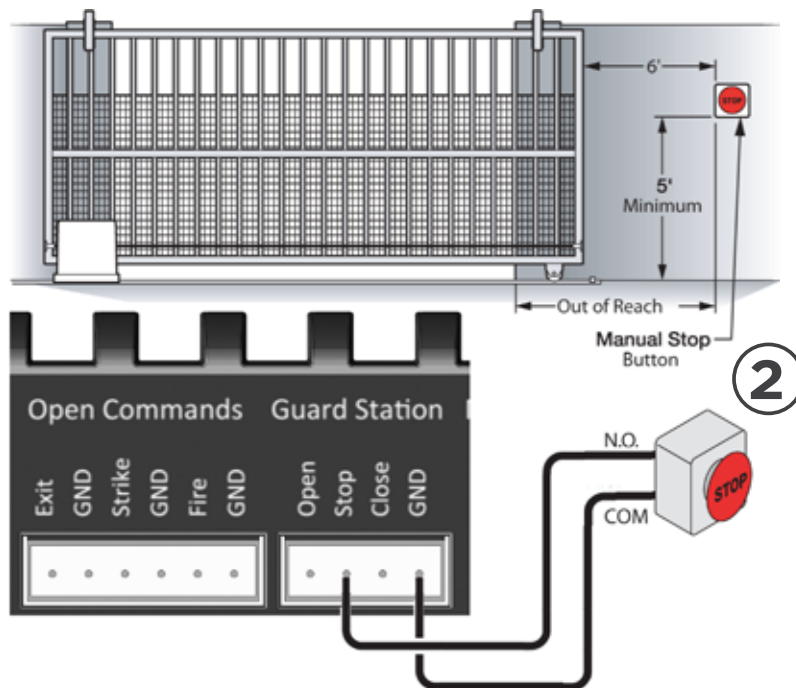

## Warning Placard Installation

- All Warning Placards must be installed where visible in the area of the gate.
- A minimum of two placards shall be installed.
- A placard is to be installed in the area of each side of the gate and be visible.

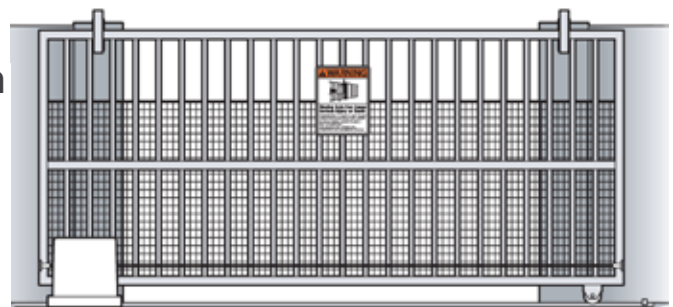

# IMPORTANT INSTALLATION INFORMATION

**⚠ CAUTION: To Reduce the Risk of Fire or Injury to Persons:**

**⚠ WARNING: For use with gates at a maximum 700 lbs. in weight or 30 ft. in length.**

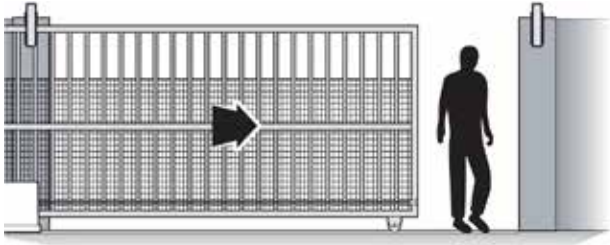

**DO NOT** allow pedestrian use of this gate



**DO NOT** install the gate operator to lift gates

## Locate Control Buttons:

1. Within sight of the gate,
2. At a minimum height of 5 feet so small children are not able to reach it; and
3. At least 6 feet away from all moving parts of the gate.

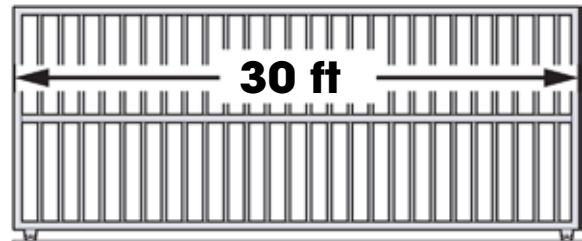
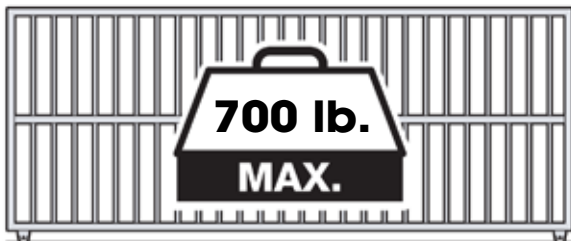
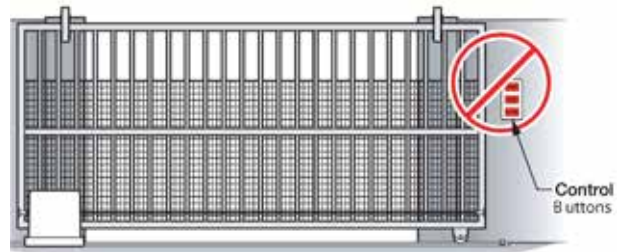

## K-2S Specifications:

UL 325 Classification:	Class I *Refer to page 9
Maximum Gate Length:	30 ft.
Maximum Gate Weight:	700 lb.
Operating Temperature:	-4°F (-20°C) to 160°F (71°C)

# GATE OPERATOR INSTALLATION

## Concrete Pad Option

1. Follow the local building code to determine the required depth of the concrete pad.
2. Pad measurements recommended by Viking Access Systems are at least 24" long, 18" wide and 24" deep to ensure the stable operation of the operator, and a minimum of 4" above level grade to avoid any flooding of the machinery.
3. Provide a sufficient number of conduit pathways for all low power accessories such as loop detector leads, maglock, non-contact sensors, contact sensors, safety and other commands. Also provide conduit for the power supply to the operator.

⚠ DO NOT run low voltage and high voltage wiring in the same conduit.

⚠ Provide at least 12" separation between low and high voltage conduits.

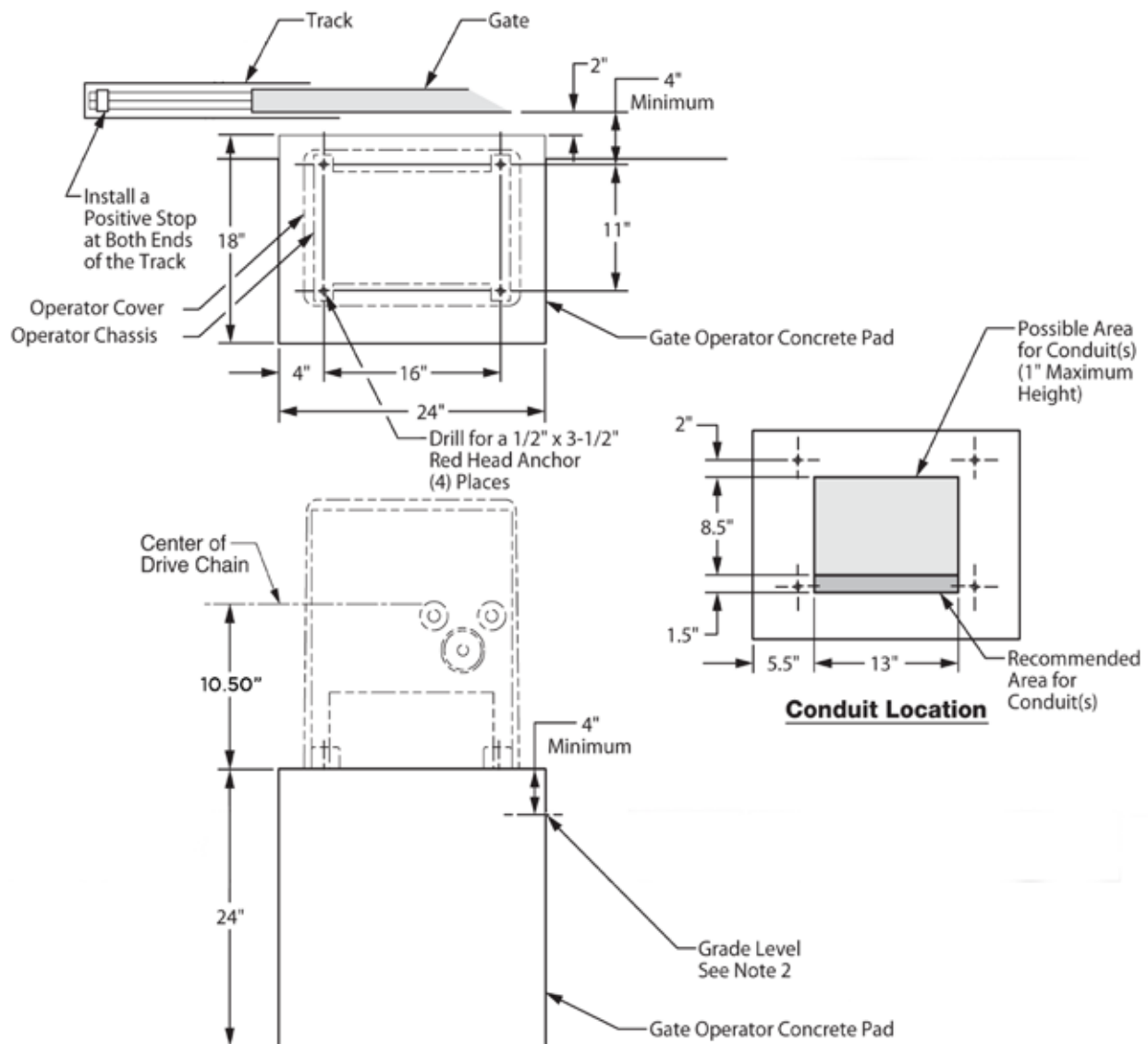



# GATE OPERATOR INSTALLATION

## Post Mounting Option

**TIP:** The operator is equipped for post mount applications and is **ready for installation**. You will only need to supply the posts and U-Bolts.

1. Consult the local building codes for the depth and concrete requirements.
2. Maximum 3.00" OD pipe.
3. Provide a sufficient number of conduit pathways for all low power accessories such as loop detector leads, maglock, non-contact sensors, contact sensors, safety and other commands. Also provide conduit for the power supply to the operator.

⚠ DO NOT run low voltage and high voltage wiring in the same conduit.

⚠ Provide at least 12" separation between low and high voltage conduits.

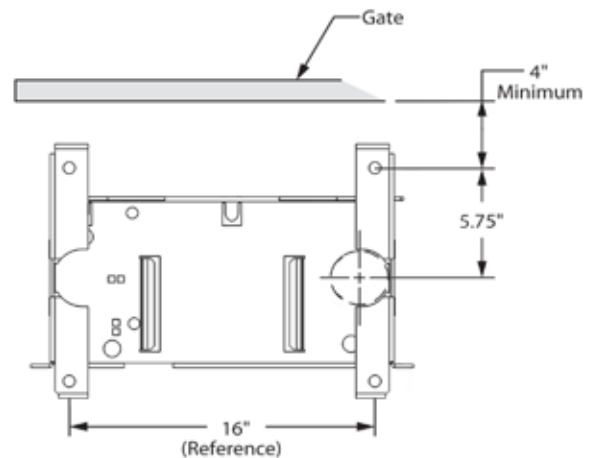
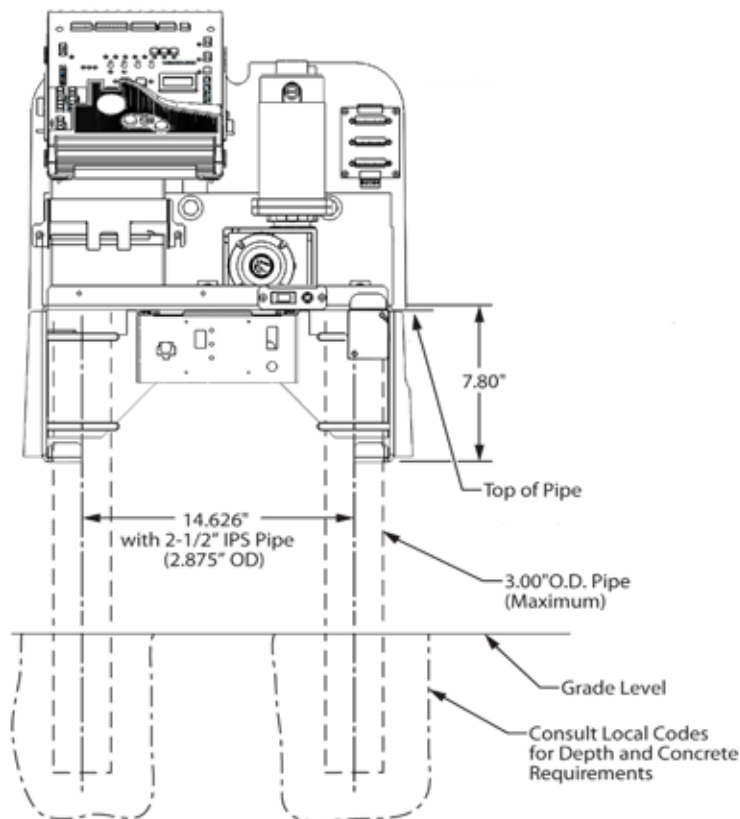

# GATE OPERATOR INSTALLATION

## Operator Positioning

**⚠ IMPORTANT:** All openings of a horizontal slide gate are guarded or screened from the bottom of the gate to a minimum of 6 feet (1.83 m) above the ground to prevent a 2-1/4 inch (57.2 mm) diameter sphere from passing through the openings anywhere in the gate, and in that portion of the adjacent fence that the gate covers in the open position.

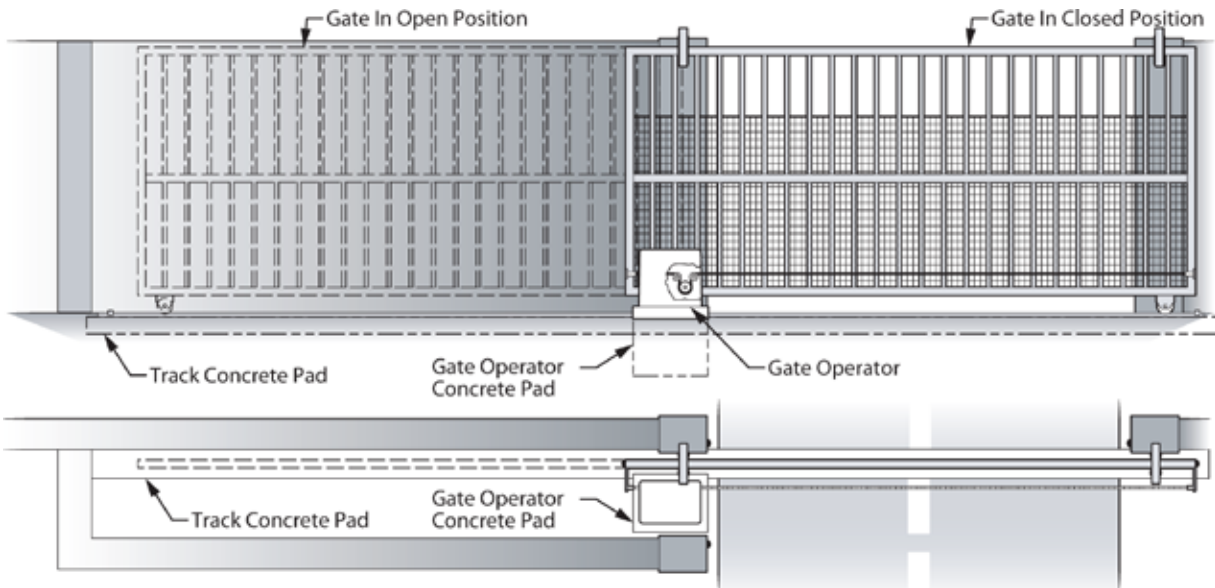
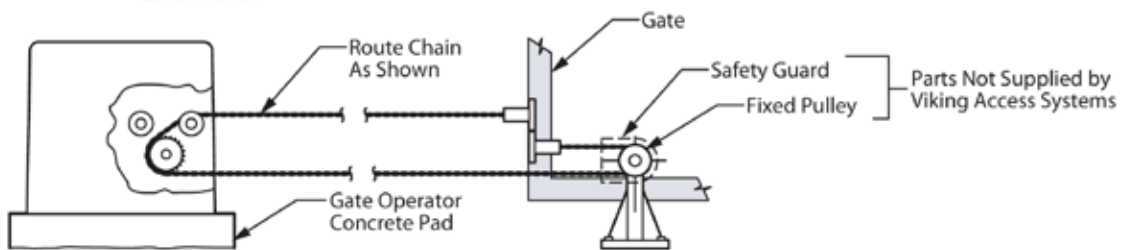
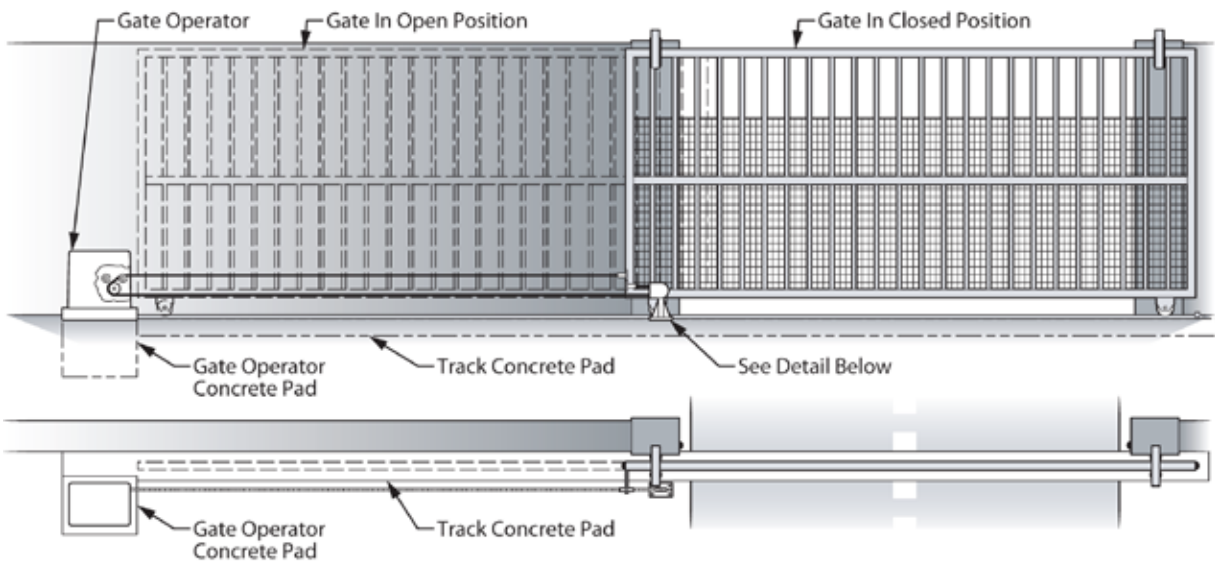

Figure A  
Plan of Front Installation



**Detail of Rear Install Chain Route**

Figure B  
Plan of Rear Installation

# GATE OPERATOR INSTALLATION

**⚠ TECHNICAL TIP:** Before completing the installation procedure;

- Open and close the gate manually, making sure there is sufficient space between the gate and adjacent walls.
- Check that the wheels are turning freely on the track and there are no restrictions while pushing the gate to the open and closed positions.
- Confirm that there is adequate spacing for the guide rollers and that there are no restrictions throughout the travel of the gate.

## STEP 1

Before securing the chassis to the concrete pad or posts, make sure the gate and operator are **LEVEL** and **PARALLEL**.

Minimum distance between the center of the chain and the inside edge of the gate frame is 4".

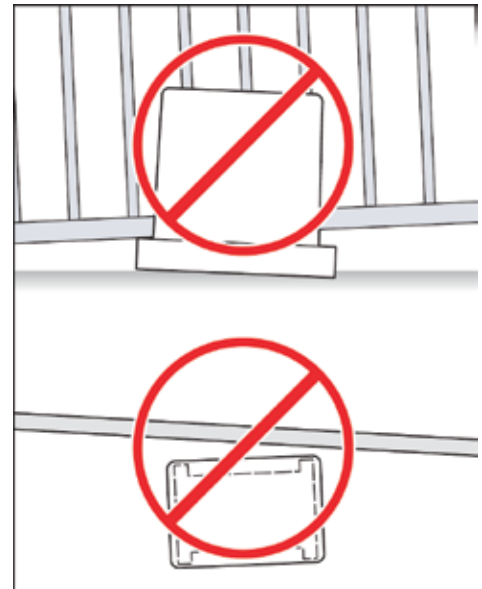
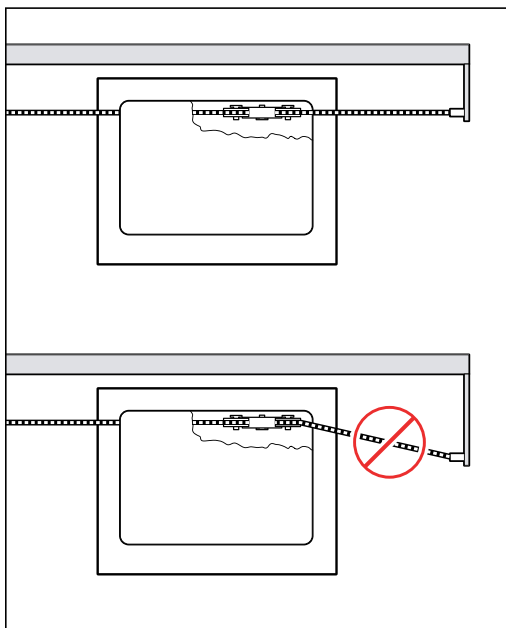

## STEP 2

Chain Installation: Before welding the provided chain brackets, make sure the chain will be in a straight line with, and at the same height as, the chain leaving the gate operator rollers.

## STEP 3

Chain Tension: The chain tension has a direct effect on the motor current draw, or work that the motor is performing. Adjust the Chain to provide 6" of slack measured from the imaginary taut line, straight down to the lowest point of the chain as illustrated below.

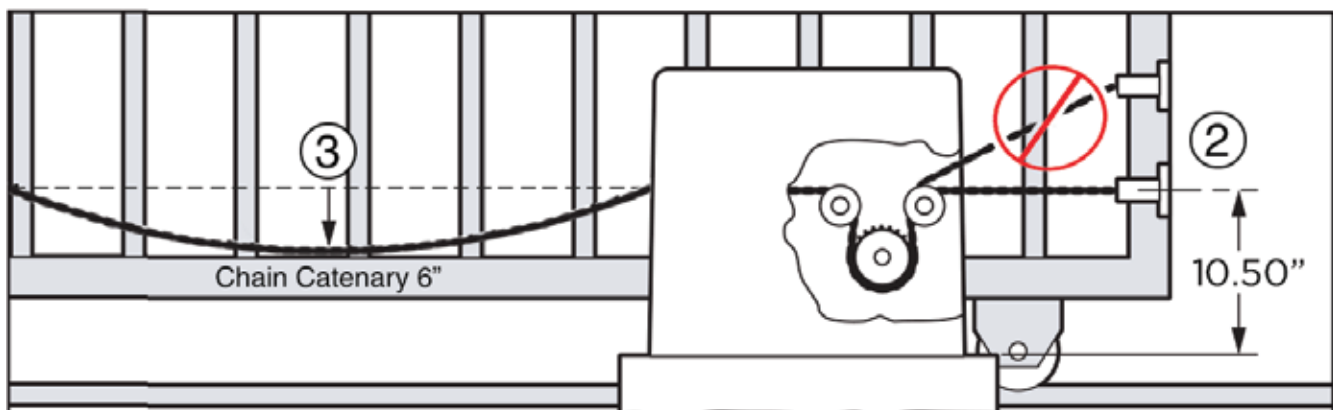

# ELECTRICAL INSTALLATION

**SAVE THESE INSTRUCTIONS** - This manual contains important instructions for the K-2s model gate operator that shall be followed during installation and maintenance of the charge controller.

## Battery Selection

- Battery is sold separately.
- Use only UL recognized 12V Sealed Lead Acid (SLA)
- 35Ah Maximum battery capacity.

## Battery Care and Location

- Use at least 12AWG wire, rated 90°C or better.
- A 35Ah battery can be stored on the chassis of the operator, below the control board.
- Ensure the battery terminals will maintain a 1/4" spacing from all other circuits and metal parts.
- Do not dispose of the battery in fire. The cells may explode. Check with local codes for possible disposal instructions.
- Do not open or mutilate the battery. Released electrolyte is corrosive and may cause damage to the eyes or skin. It may be toxic if swallowed.
- Exercise care in handling batteries in order not to short the battery with conducting materials such as rings, bracelets and keys.
- CAUTION - A battery can present a risk of electrical shock, burn from high short circuit current, fire or explosion from vented gasses. Observe proper precautions.
- Observe proper polarity orientation between the battery and charging circuit.

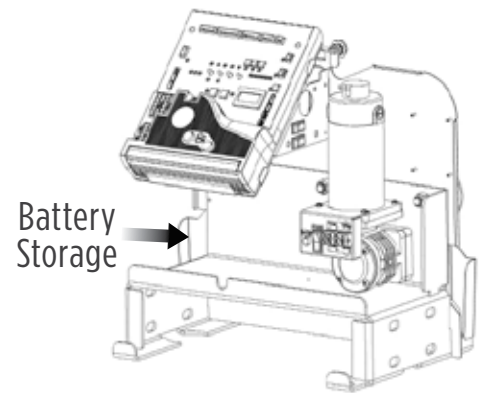

## Solar Panel Selection

- Solar panel(s) are sold separately.
- Use only UL Listed 12V solar panel(s), such as Viking part #s:

Wattage	Viking Part#	Open-Circuit Voltage	Short-Circuit Current
20 Watts	VA-SO20W	21.7V	1.25A
40 Watts	VA-SO40W	21.8V	2.57A

## Ratings

System Voltage:	12V	
Max. Solar Wattage:	40W	
Max. Solar Voltage:	29V	
Max. Battery Capacity:	35Ah	
Min. Battery Voltage:	8V	
Max. Charger Load Current:	3A	
Output Voltage for Controls:	24V	This is the voltage the control board will provide

**⚠ Important:** The number of cycles achieved daily is dependent on many factors, including current draw of the motor and accessories, and local solar radiation data. **If more specific information is needed please consult with Viking Access Systems. For more information regarding solar energy refer to:** <http://rredc.nrel.gov/solar/pubs/redbook/>

# ELECTRICAL INSTALLATION

## Solar Panel Care and Location

- Where it will receive maximum sunlight throughout the year.
- Avoid trees and buildings or obstructions, which could cast shadows on the panel.
- South facing and tilted at an inclined angle that is equal to latitude.
- If dirt build-up becomes excessive, clean the glass with a soft cloth using a mild detergent and water.
- Install solar panels in the following conditions:
  - Operating temperature: -40°F to 185°F
  - Humidity: Below 85RH%
  - Wind pressure: Below 50.12lb / ft<sup>2</sup> (2400Pa)
  - Snow load pressure: Below 112.76lb / ft<sup>2</sup> (5400Pa)
- DO NOT install the solar panel near open flames or flammable materials.
- DO NOT install the solar panel where there is a risk of being immersed in water or continually exposed to water from a sprinkle, fountain, etc..

## Solar Panel Safety Precautions

- ⚠ Installation must be performed by a qualified technician.
- Before installing your system, contact local authorities and determine the necessary permit, installation and inspection requirements.
- Follow all local codes and guidelines.
- To reduce the risk of electrical shock or burns, the solar panel must be covered with an opaque material during installation.
- Do not touch live terminals with bare hands as they can present a risk of electrical shock, burn or fire.

## Solar Panel Installation (per article 690 of ANSI/NFPA 70)

- Use appropriate methods to mount the solar panel. Fall of the panel from high places will cause death, injury or damage.
- The solar panel must be mounted on a post with a supporting structure to support wind and snow loads rated for use by the appropriate local or civil codes.
- Use stainless steel washers between the panel and the supporting frame to prevent electrolysis corrosion.
- Use conduit and the appropriate wire type for outdoor applications.
- Properly ground solar panel and operator according to NEC code.
- Use the appropriate wire size according to distance and the maximum power (Watt) rating of the solar panel, or panels combined.
- Use at least 16 AWG photovoltaic cable or 90°C, sunlight and moisture resistant direct burial cable or better.
- WARNING - This charge controller must be used with an external GFDI device as required by article 690 of the National Electric Code for the installation location.

### Tips for proper ground installation:

- Use a ground rod to provide a ground reference.
- Consult your city code and be aware of under-ground services in the site of the gate operator to prevent inconveniences.
- Always use a single bonding point for grounding.
- All ground wires must be as short and as thick as possible.
- Prevent unnecessary turns or loops in all ground wires.

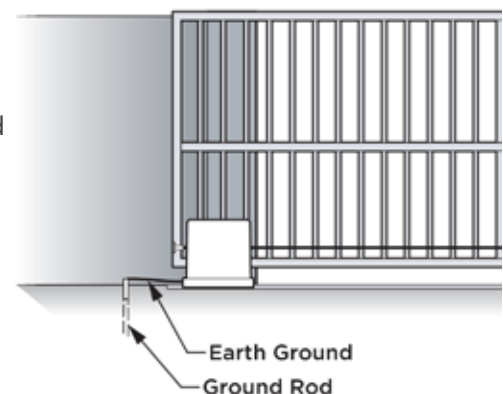

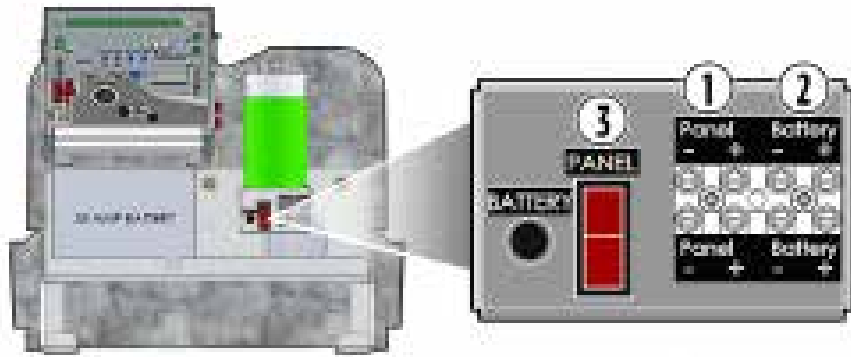

## Power Connections

**⚠ Caution: Ensure correct polarity**

**Step 1:** Connect the 12V Solar Panel to the terminals labeled "PANEL". (1)

**Step 2:** Connect the 12V Battery to the terminals labeled "Battery". (2)

**Step 3:** Turn the "PANEL" switch to the "RESET" position. (3)

**Step 4:** Turn the "POWER" Switch to the "RESET" position. (4)

**Step 5:** Connect the Power Harness (5) and verify the "POWER" indicator (5a) is illuminated solid.

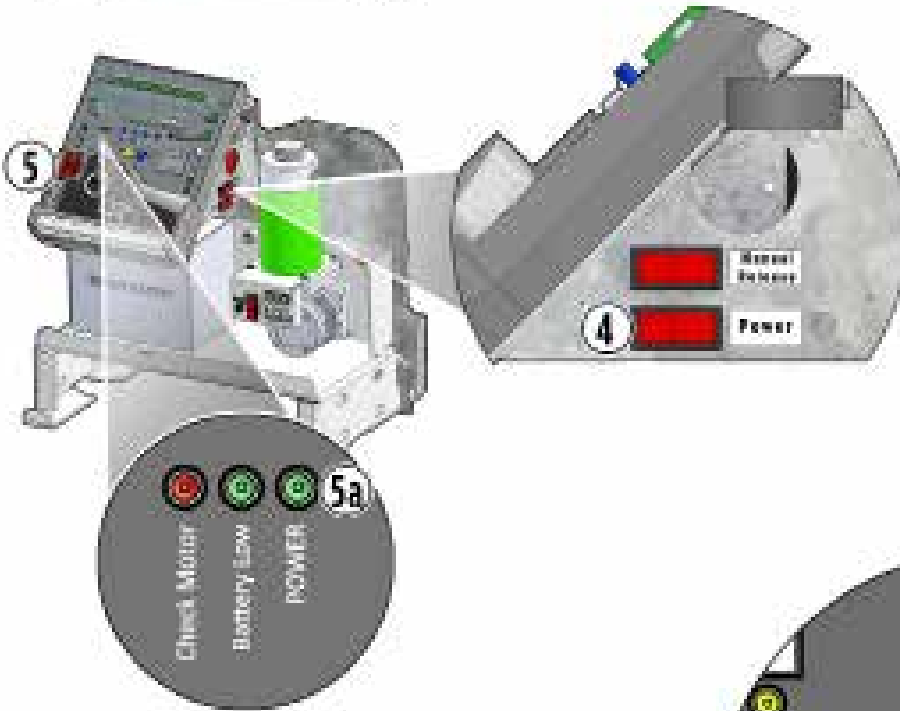

## Power Saving Tip:

The solar VFlex "control board" shuts down the power at the "Aux. Pwr" Terminal (A) when the board is in sleep mode.

To save energy, get the power for your non-essential devices (such as photo beams) from this terminal.

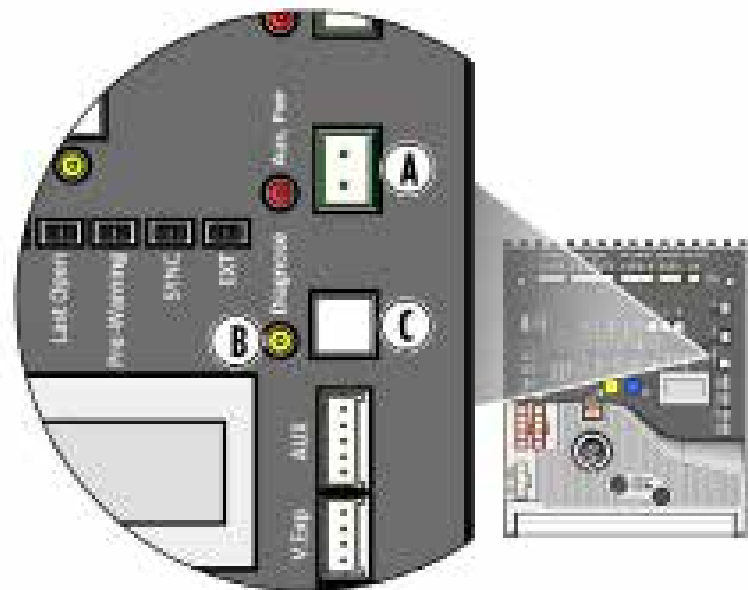

## LCD Display References

### Solar Related Error Messages

ERR PANEL LOW	Indicates that the voltage being provided from the solar panel is too low.
ERR PANEL HIGH	Indicates that the voltage being provided from the solar panel is too High.
ERR SOLAR NO PANEL	Indicates that there is no voltage being provided from the solar panel
ERR NO SOL UNIT	Indicates that there is no voltage being provided from the solar panel.
ERR CHRG HIGH	Potential problem with the Solar Charger.
ERR BAT LOW	The battery is low

### Diagnostics steps

If errors are detected the "Diagnose" indicator (B) starts flashing.

Error messages will display automatically, otherwise press and release the "Diagnose" button (C) until the error messages appear.

# LIMITS SETUP

**⚠ IMPORTANT:** In the event of a complete power failure, including battery backup, the limits positions may have been cleared and will need to be reset by following the steps below.

## STEP 1

Connect the “Motor Harness” to the Control Board.

- “OPEN RIGHT” Connector if the gate opens to the Right, when viewed from inside.
- “OPEN LEFT” Connector if the gate opens to the Left, when viewed from inside.

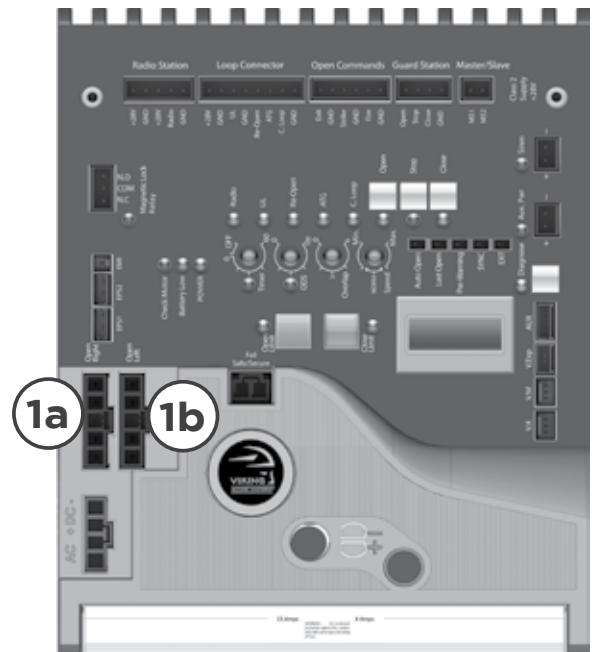

## STEP 2

Move the gate to the desired open position then press and hold the “Open Limit” button until the LED stops flashing and illuminates solid.

## STEP 3

Move the gate to the desired close position then press and hold the “Close Limit” button until the LED stops flashing and illuminates solid.

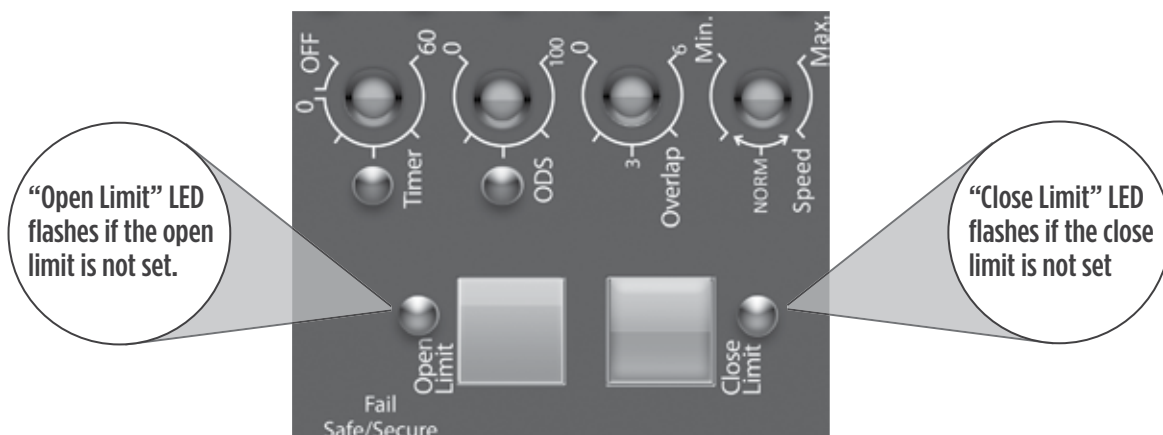

**Tip:** The gate can be moved electronically with the “Open”, “Stop” and “Close” buttons on the Control Board or manually by following the instructions on page 11.

# LIMITS SETUP

## ⚠ NOTE:

1. The 1st cycle after the limit setup is the “Learn Cycle”. Allow a complete cycle to confirm your settings.
2. During the limit setup process, the operator will run at half speed.

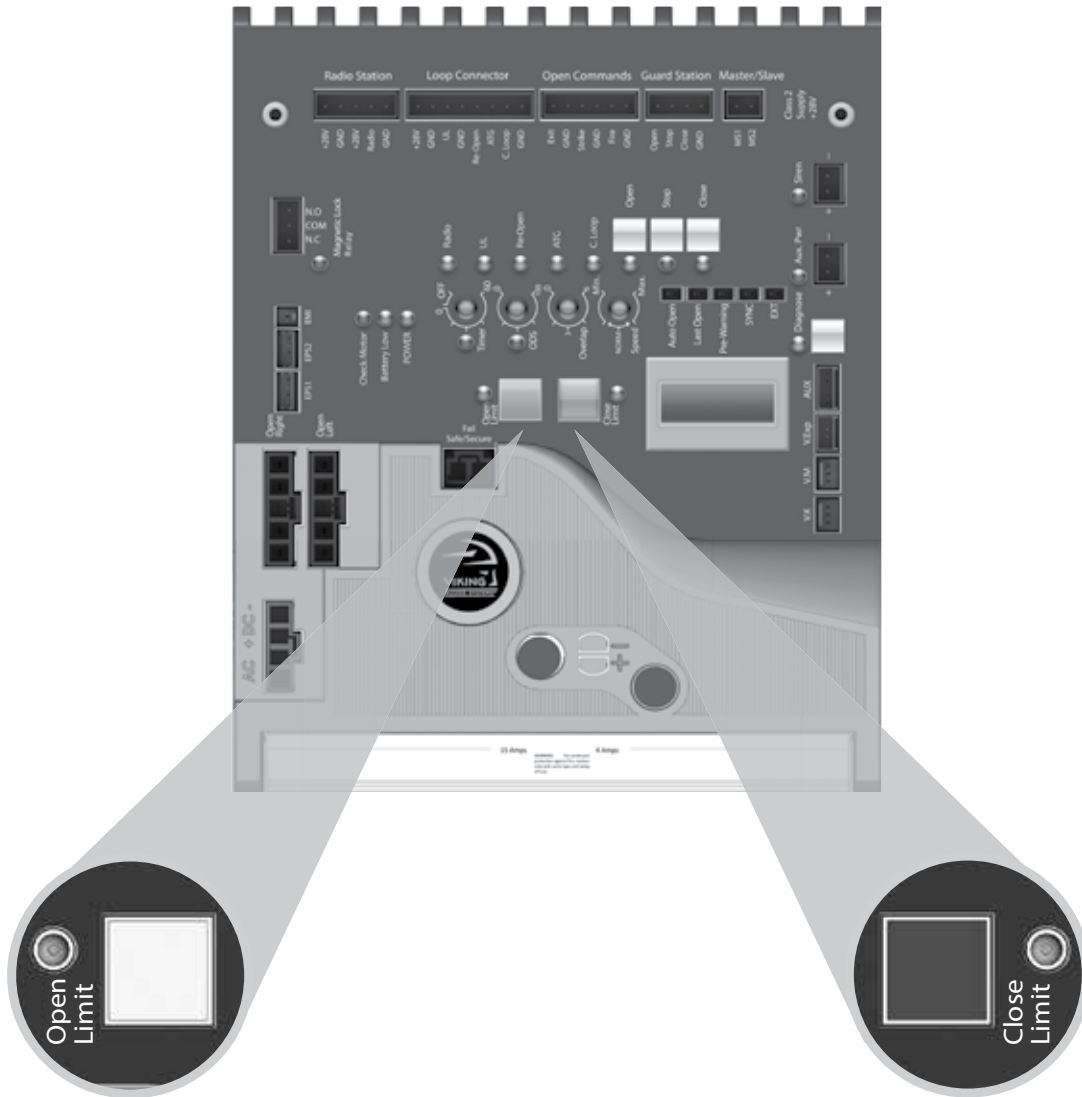

### To Readjust the Open Limit:

1. Clear the current limit setting by holding down the “Open Limit” button until the LED is flashing.
2. Repeat STEP 2 on page 21 to set the limit.

### To Readjust the Close Limit:

1. Clear the current limit setting by holding down the “Close Limit” button until the LED is flashing.
2. Repeat STEP 3 on page 21 to set the limit.



# MASTER/SLAVE SETUP

## Two Wire Communication

**⚠ IMPORTANT:** DO NOT run the Master/Slave communication cable in the same conduit or within 12" of 115 - 230V power supply cables.

**⚠ Technical Tip:** DO NOT set the "Timer" and/or "Overlap" features on both operators Control Boards. Only turn these features on at the Master Control Board.

### Step 1

Connect shielded cable to "Master/Slave" connectors at the control boards

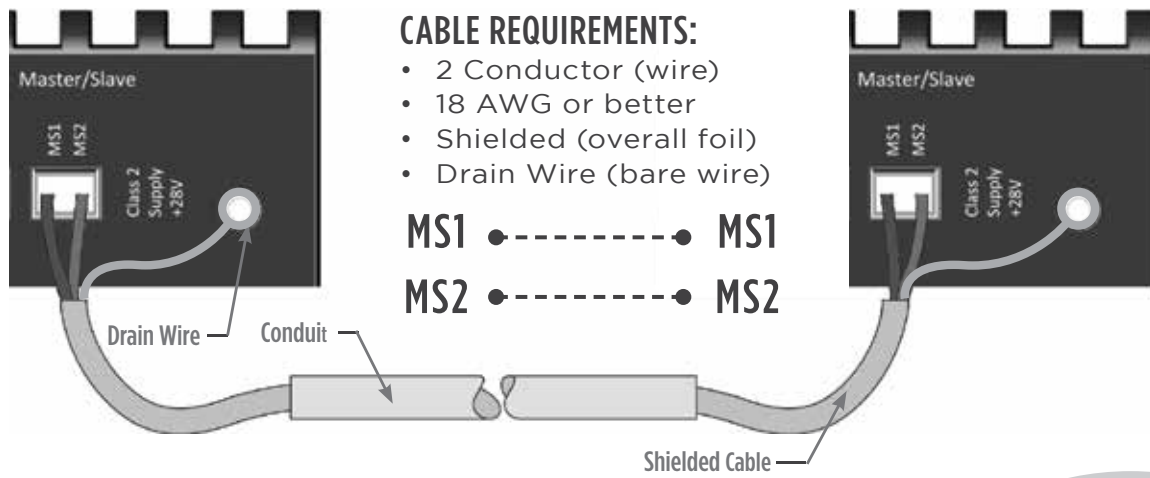

### Step 2

At the Master Operator:

Connect the entrapment protection sensor(s) as described on page 11.

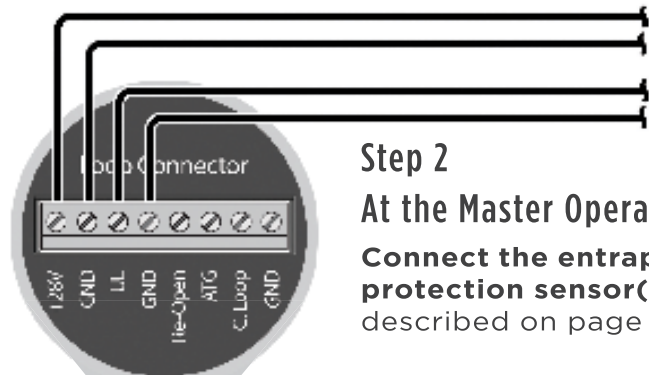

### Step 3

At the Slave Operator:

Turn ON the SLAVE MODE Feature:

- Toggle the "Diagnose" button until you see SLAVE MODE on the LCD Display.
- Default setting is OFF.
- Press and hold the "Stop" button.
- Toggle the "Diagnose" button once.
- The feature should now be displayed as "ON".

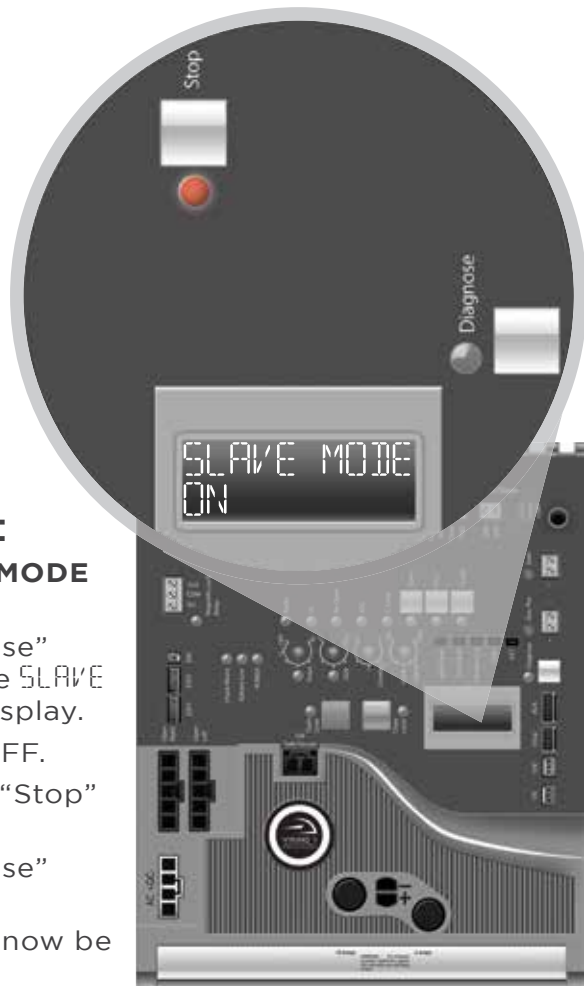

# CONTROL BOARD SETUP

## Initial Settings

### “Timer” Hold Open Timer

Automatically closes the gate after the selected amount of time from 1-60 seconds.

Turning the dial between “0” and “OFF” will disable this feature, requiring a close command to close the gate.

### “Overlap” Overlap Delay

Delays the gate from opening for the selected amount of time from 1-6 seconds.

⚠ Typically not used on slide gates. For Master/Slave application, the control board that has this feature turned on is the master and will close first.

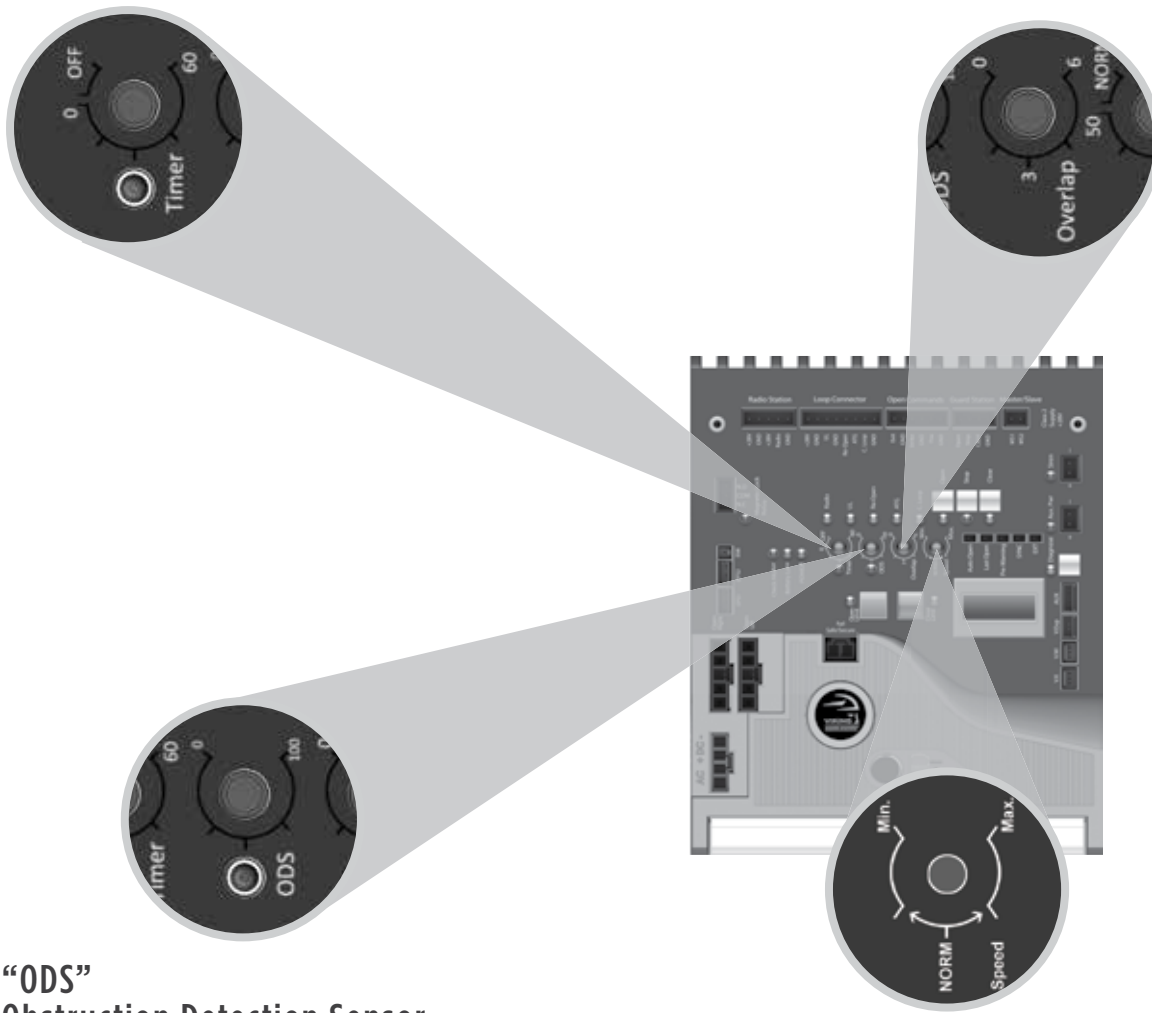

### “ODS” Obstruction Detection Sensor

Sets the amount of force required to trip the inherent obstruction sensor.

See page 26 for more details about this feature.

### “Speed” Motor Speed

Increases or decreases the speed of gate travel.

# CONTROL BOARD SETUP

## Initial Settings

**NOTE:** Installing a shunt, or jumper, on the pins will activate the feature.

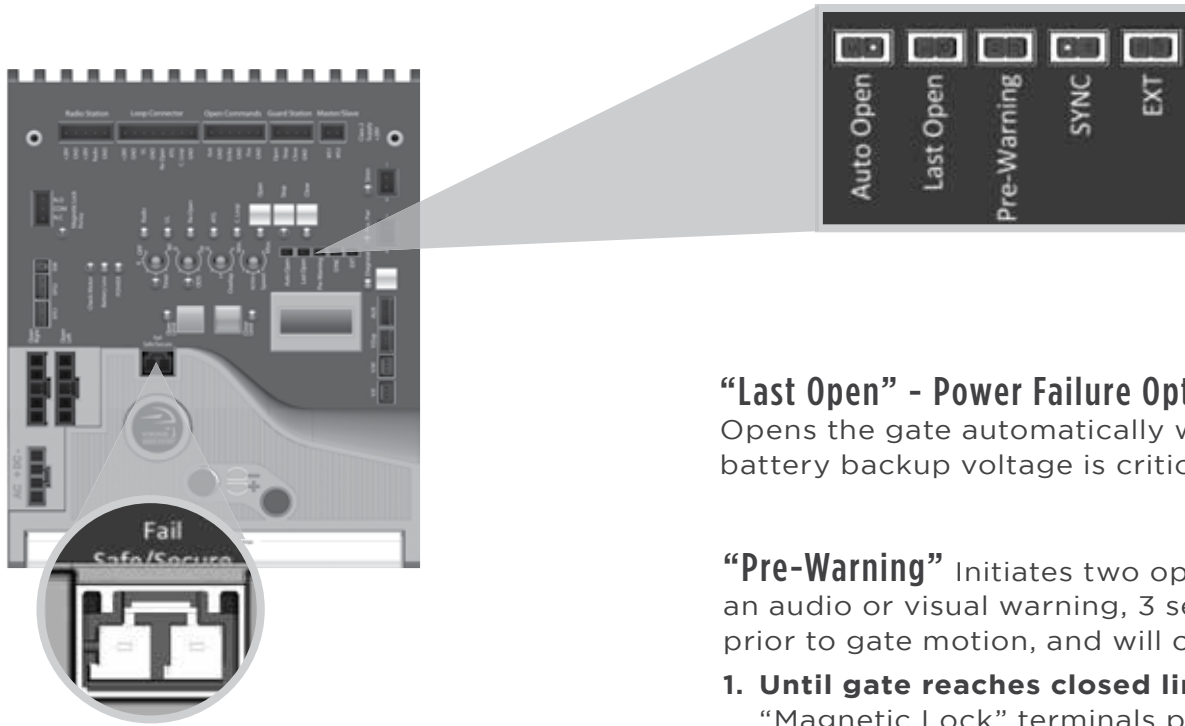

### “Fail Safe/Secure”

During complete power failure, including battery power; determines the force required to manually move the gate.

- **Fail Safe Mode:**  
By removing the wire-jumper plug from the “Fail Safe/Secure” connector:  
The gate can move manually with a relatively low amount of force.
- **Fail Secure Mode:**  
By inserting the wire-jumper plug into the “Fail Safe/Secure” connector:  
The gate will not move manually.

### “Last Open” - Power Failure Option

Opens the gate automatically when the battery backup voltage is critically low.

“Pre-Warning” Initiates two options for an audio or visual warning, 3 seconds prior to gate motion, and will continue:

**1. Until gate reaches closed limit:**

“Magnetic Lock” terminals provide a contact between “COM” and “N.O.”.

**2. Until gate reaches either limit:**

“AUX. PWR” terminals provide 24VDC.

“Sync” Used only in conjunction with the Viking Barrier gate operator model B-12. Activating this feature allows for synchronized operation with the B-12 operator. See page 35.

“EXT” Available for future developments.

**⚠ IMPORTANT:** Regardless of the power failure options chosen, the gate can be moved manually with a relatively low amount of force by following the steps for “Manual Release” as outlined at on page 11.

# CONTROL BOARD SETUP

## Obstruction Detection Sensor (ODS)

**⚠ IMPORTANT:** The appropriate “ODS” setting is dependant upon the gate installation and construction. Set this feature accordingly. Additional Safety equipment should be used to reduce possible risk of injury or vehicle damage.

### “ODS” Obstruction Detection Sensor

The Obstruction Sensor detects obstructions in the path of the traveling gate. The dial sets the amount of force required to activate the operators inherent obstruction detection.

Setting the dial to “0” will require the least amount of force to activate;

Setting the dial to “100” will require the maximum amount of force to activate.

**UL325 standard requires** an audio alarm to go off after two consecutive entrapment events sensed by the Inherent Entrapment Protection of the Gate Operator.

The audio alarm will sound for a period of 5 minutes or until a Stop command or the “Alarm Reset” switch has been actuated. (refer to page 12)

### When the Obstruction Sensor detects an obstruction it will:

1. Stop the gate’s movement and reverse it momentarily.
2. Bring the gate to a resting position.
3. Disable the Hold Open Timer feature until the Gate Operator receives a new command.

### If second obstruction is detected before the gate reaches either limit it will:

1. Stop the gate’s movement.
2. Disable the Gate Operator.
3. Sound the UL Alarm
4. A STOP command must be provided to disable the alarm and continue operation.

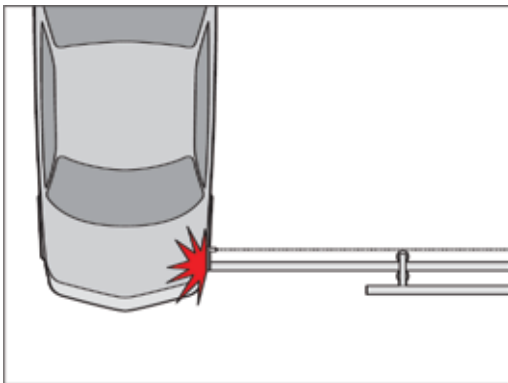

**⚠ TECHNICAL TIP:** The Status LED for the “ODS” will indicate the following when it has been triggered.

- A. Solid:** Obstruction. Detected a sudden or abrupt increase in gate resistance.
- B. Flashing:** Overload. Detected a more subtle, but sustained increase in gate resistance.

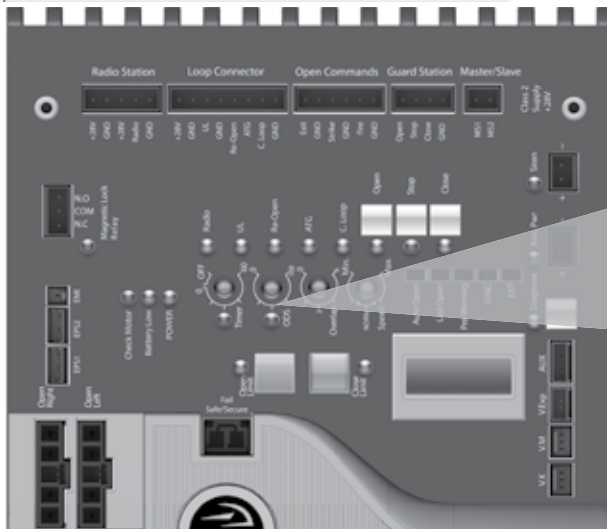

**(THIS PAGE LEFT BLANK INTENTIONALLY)**

# ACCESSORY CONNECTIONS

⚠ Cable use in Class 2 circuit to an external device shall be type CL2, CL2P, CL2R, CL2X or other cable with equivalent or better electrical, mechanical, and flammability ratings.

## UL (Monitored Input Terminal)

The “UL” input terminal protects against entrapment in both the opening and closing directions. Input will reverse the gate momentarily in the opposite direction it was traveling when a connected device is triggered. see pages 10-11.

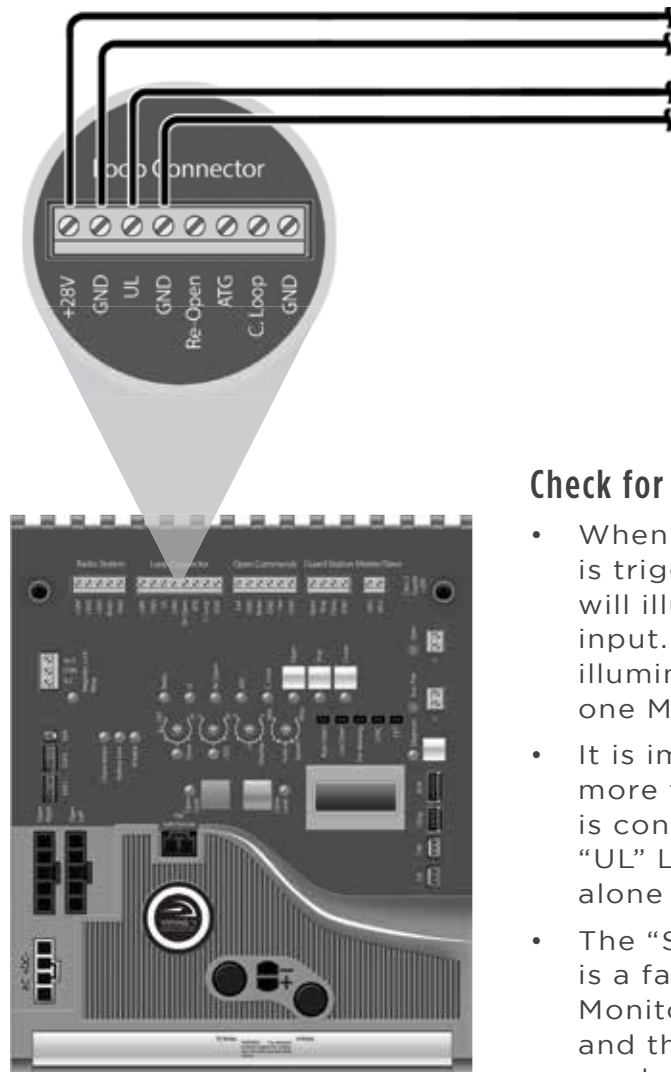

### Check for proper operation:

- When a connected device is triggered, the “UL” LED will illuminate to indicate an input. The “Stop” LED will also illuminate if there is more than one Monitored device connected.
- It is important to note that if more than one Monitored device is connected to this terminal, the “UL” LED will be illuminated. This alone is inconsequential.
- The “Stop” LED will flash if there is a failure with at least one Monitored entrapment sensor and the gate operator will be rendered inoperable.

⚠ **TECHNICAL TIP:** For more information regarding accessory connections to the control board and individual input terminal functions, refer to “Appendix (A)” pages 42-43.

# ACCESSORY CONNECTIONS

**⚠ Cable use in Class 2 circuit to an external device shall be type CL2, CL2P, CL2R, CL2X or other cable with equivalent or better electrical, mechanical, and flammability ratings.**

## Re-Open (Monitored Input Terminal)

The “Re-Open” input terminal protects against entrapment in the closing direction ONLY. Input will reverse the gate all the way to the Open Limit when a connected device is triggered. see pages 10-11.

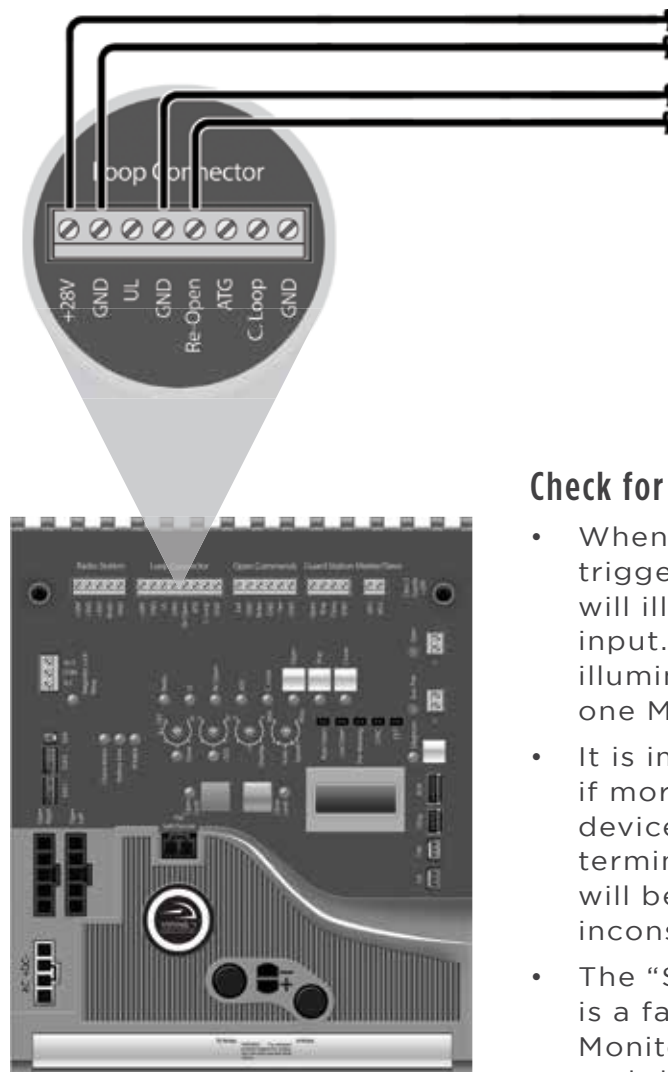

### Check for proper operation:

- When a connected device is triggered, the “Re-Open” LED will illuminate to indicate an input. The “Stop” LED will also illuminate if there is more than one Monitored device connected.
- It is important to note that if more than one Monitored device is connected to this terminal, the “Re-Open” LED will be illuminated. This alone is inconsequential.
- The “Stop” LED will flash if there is a failure with at least one Monitored entrapment sensor and the gate operator will be rendered inoperable.

**⚠ TECHNICAL TIP:** For more information regarding accessory connections to the control board and individual input terminal functions, refer to “Appendix (A)” pages 42-43.

# ACCESSORY CONNECTIONS

⚠ Cable use in Class 2 circuit to an external device shall be type CL2, CL2P, CL2R, CL2X or other cable with equivalent or better electrical, mechanical, and flammability ratings.

## Radio Receiver (Typical)

⚠ **IMPORTANT:** The Hold Open “Timer” setting (page 24) affects how the gate will respond to the radio receiver command.

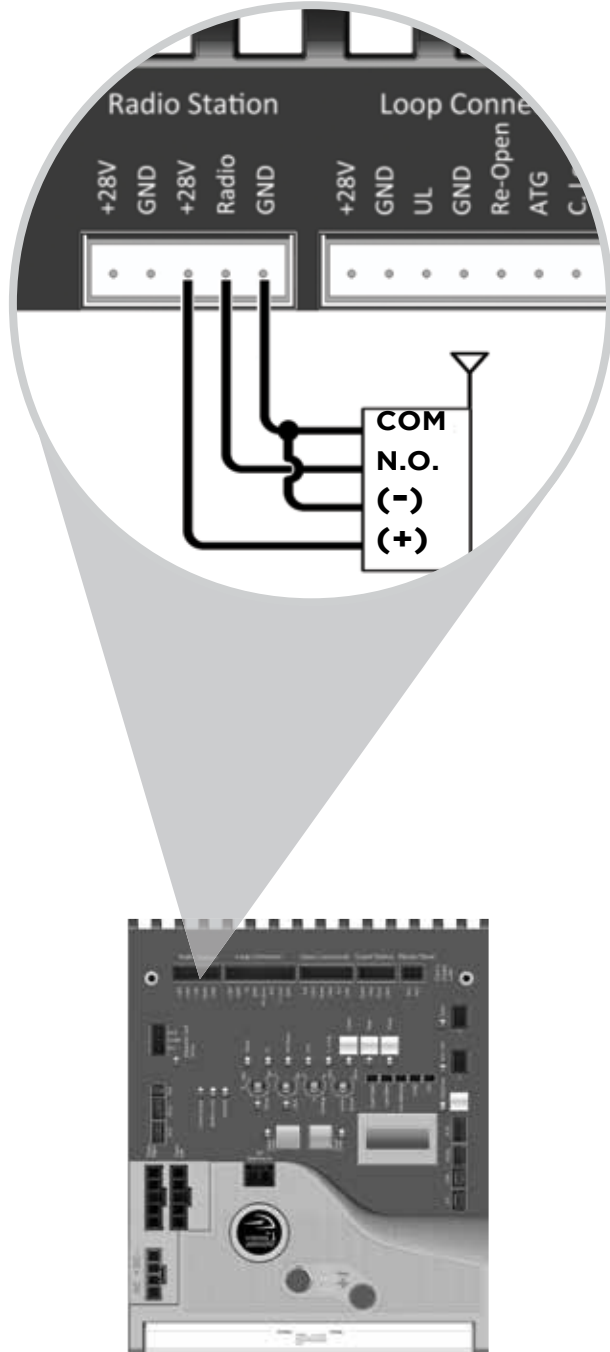

The control board provides two modes of operation that a radio receiver can control the gate:

### Open-Stop-Close

1. By having the radio receiver connected as illustrated and with the Hold Open Timer OFF (see page 24):

Every command of the radio transmitter will control the gate as follows:

- First command opens the gate,
- Second command stops the gate and
- Third command closes the gate
- Any subsequent commands will continue in the same order to control the gate.

This type of configuration is not recommended for commercial installations.

### Open Only

2. By having the radio receiver connected as illustrated and with the Hold Open Timer ON (see page 24):

Each command of the radio transmitter is **ALWAYS AN OPEN COMMAND** to the gate.

### For maximum reception range:

Locate the radio antenna to the top of the gate column.

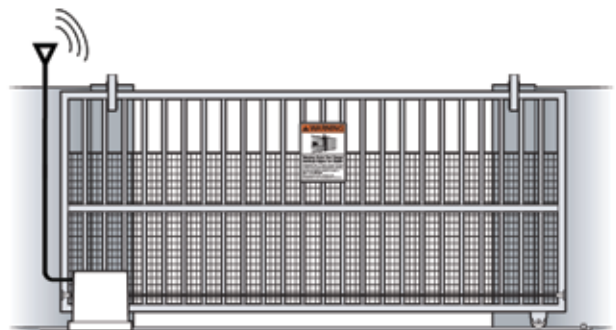

⚠ **TECHNICAL TIP:** For more information regarding accessory connections and terminal functions, refer to “Appendix (A)” on pages 42-43.

See “Appendix (B)” on page 44 for connecting common radio receiver models.



# ACCESSORY CONNECTIONS

⚠ Cable use in Class 2 circuit to an external device shall be type CL2, CL2P, CL2R, CL2X or other cable with equivalent or better electrical, mechanical, and flammability ratings.

## Anti-Tailgate, Open Commands & Guard Station

⚠ **TECHNICAL TIP:** For more information regarding accessory connections and terminal functions, refer to “Appendix (A)” on pages 42-43.

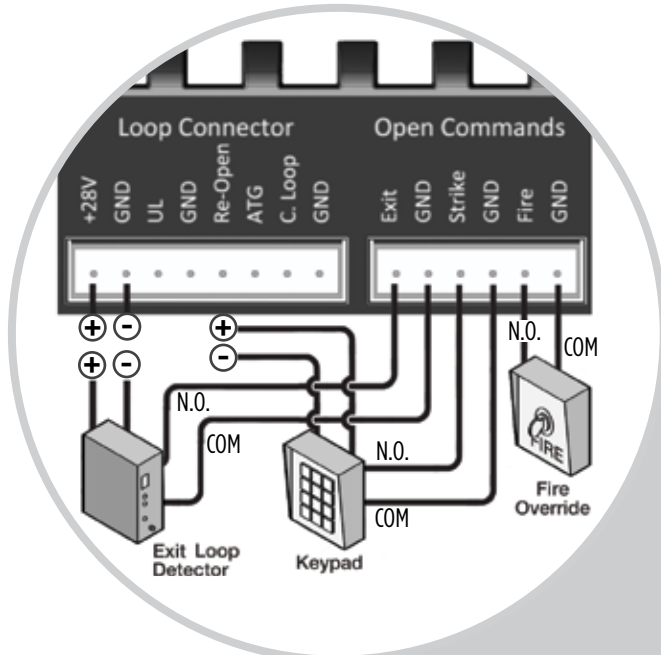

### Open Commands

“Exit”, “Fire” and “Strike” input terminals all provide an open command to the control board. Any device connected as shown will open the gate.

### Guard Station

⚠ All three buttons must be a Normally Open “N.O.” type of switch, and can share the same common “C” connection to “GND”.

### “ATG” Anti-Tailgate

This input will stop the gate when the vehicle triggers the sensor, then closes the gate when the vehicle leaves the sensor, preventing unauthorized vehicles from entry.

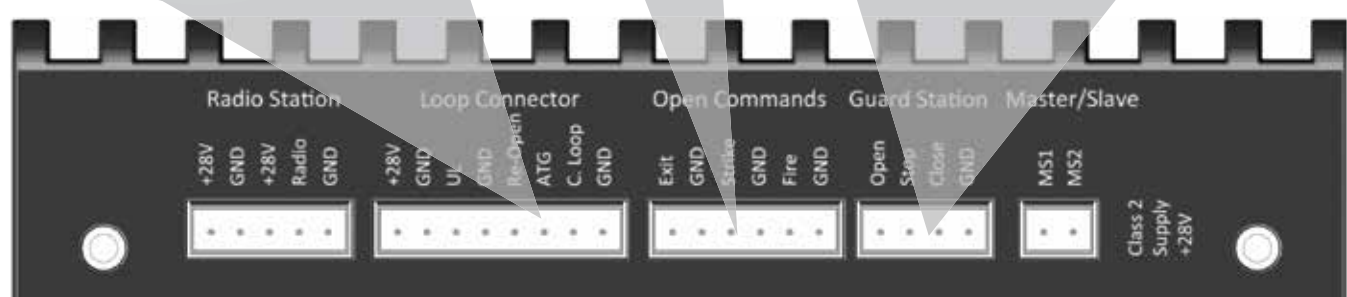
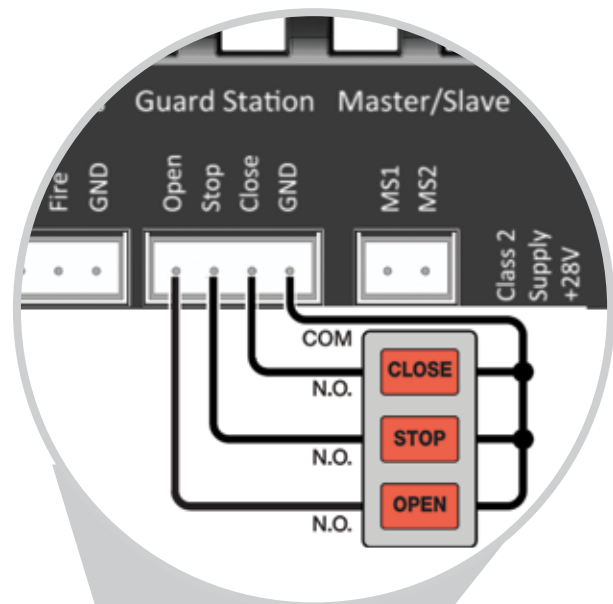
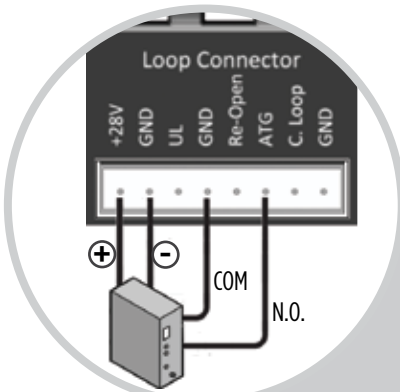

# ACCESSORY CONNECTIONS

## Viking Loop Rack

**TIP:** This operator may be equipped with a pre-wired **Loop Rack** that plug-in type loop detectors can be connected to. This provides a convenient alternative to the box type loop detectors that would need to be wired to the control board. Viking does not provide either type of loop detectors.

**Loop Rack: Part # VA-LR**

**Loop Rack Wiring Harness: Part # VA-LRH**

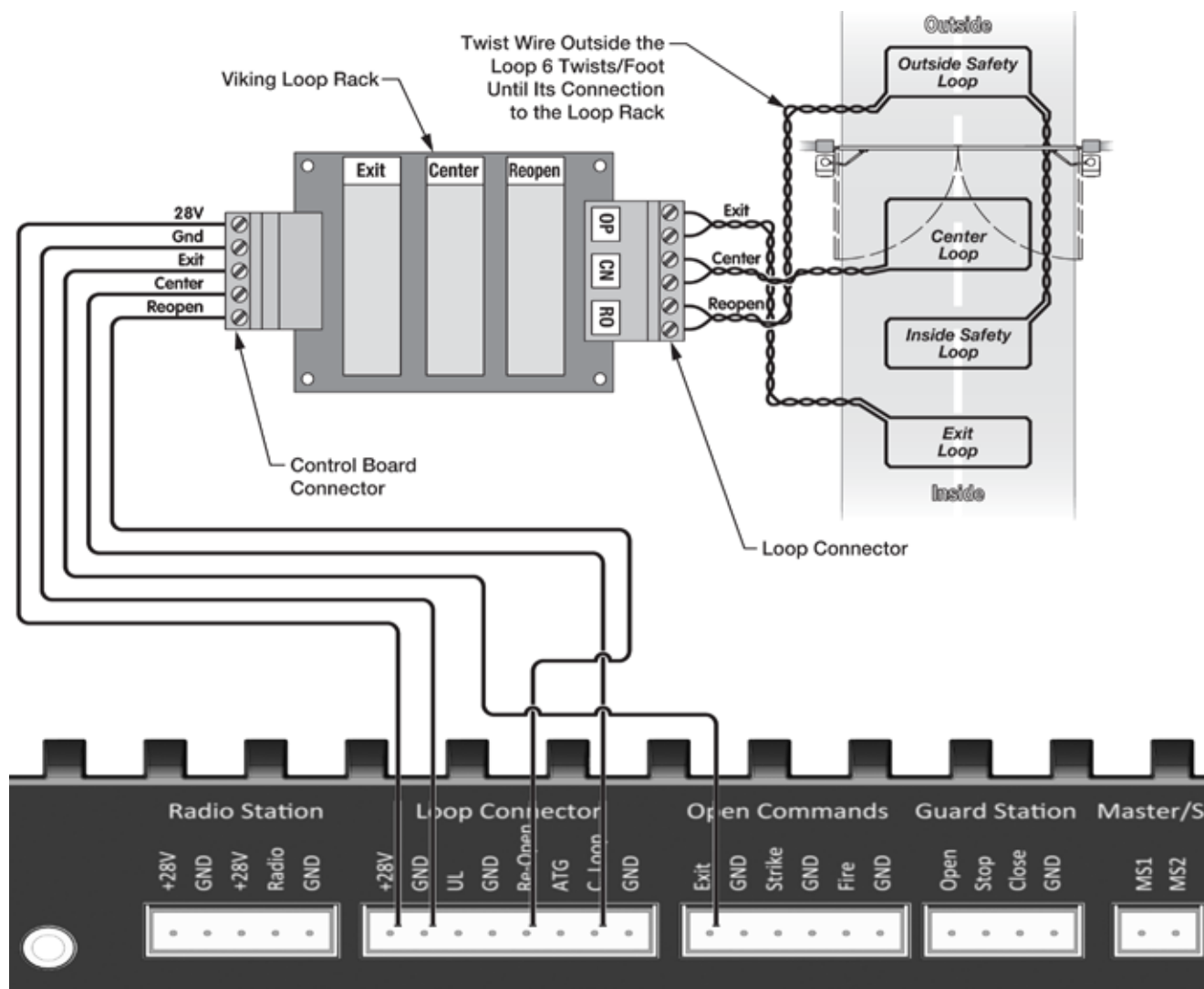

# ACCESSORY CONNECTIONS

## Guidelines for Loop Installation

1. Prevent sharp corners in the geometry of the loop sensor.
2. Install the appropriate number of turns for your loop geometry based on the loop perimeter. Use Table C (below) as a guide.
3. Use XLP (cross-linked-polyethylene) type of wire. This wire reduces the effects of moisture and other environmental events in altering the functionality of the vehicular loop detector.
4. Twist the lead wire at least 6 turns per foot.
5. Use BACKER-ROD to minimize damage to the loop detector wire prior to using the sealant.
6. Place the loop detector wire and adjust the sensitivity of the vehicular loop detector unit in a way to minimize the effects of the gate over the loop detector wire.

**⚠ IMPORTANT!** Some of the following parameters may affect the proper functionality of the vehicular loop detector.

**Consult the manufacturer of the vehicular loop detector and/or loop wire.**

- Gate size
- Number of turns in the loop sensor wire
- Distance of the loop sensor wire to the gate at either at the open or close position

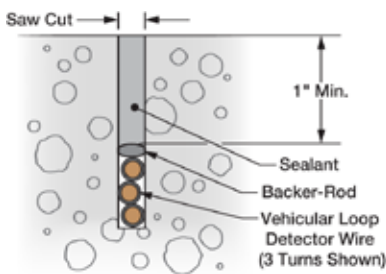

**Table C - Recommended Number of Turns**

Perimeter (ft.)	Number of Turns
10	5
20	4
30-40	3
50-100	2

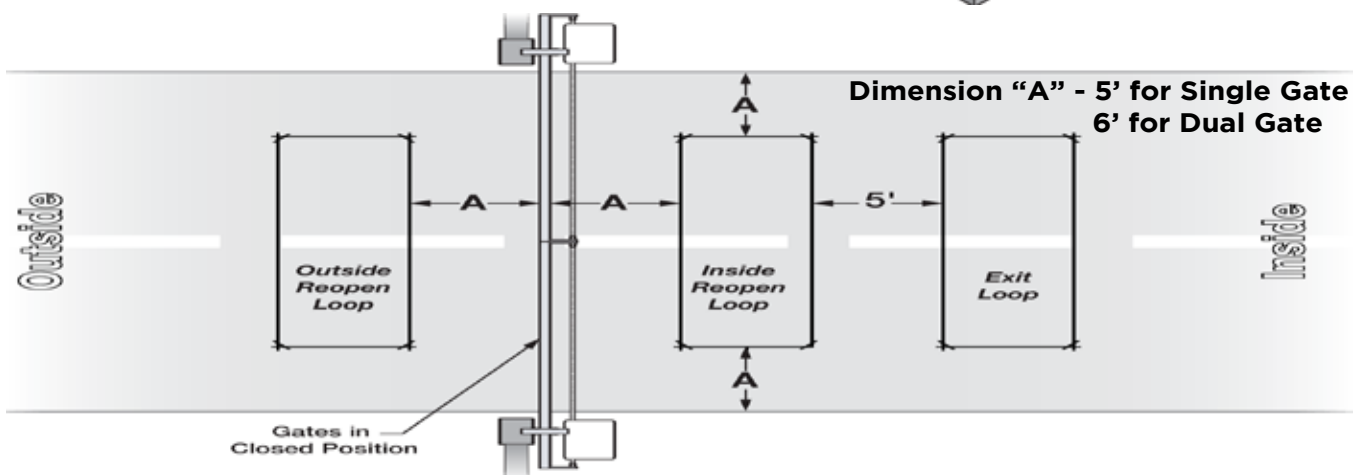
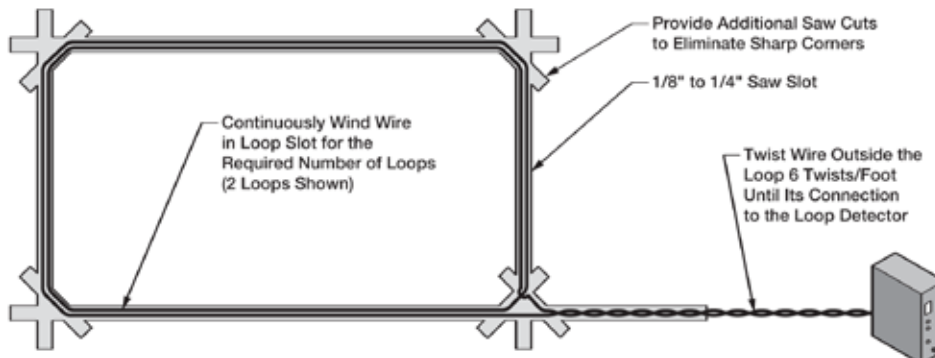

**(THIS PAGE LEFT BLANK INTENTIONALLY)**

# ACCESSORY CONNECTIONS

## Barrier Arm Synchronization

**NOTE:** The Control Board provides a convenient solution for applications that require synchronized operation with the Barrier Arm Operator.

This type of application opens and closes in the following pattern:

1. Open Command is provided only to the Barrier Arm operator.
2. The Barrier Arm will send an open input to the Viking gate operator; Barrier Arm will delay to open until the Viking gate operator reaches its Open Limit.
3. Barrier Arm will close first; the Viking gate operator will delay to close until the Barrier Arm reaches its Close Limit.

### STEP 1 (Figure A)

At the Barrier Arm operator, connect the device(s) that will be used as the primary OPEN input.

### STEP 2 (Figure A & B)

Connect the Barrier Arms' designated sync output terminals to the Strike input at the Viking gate operator.

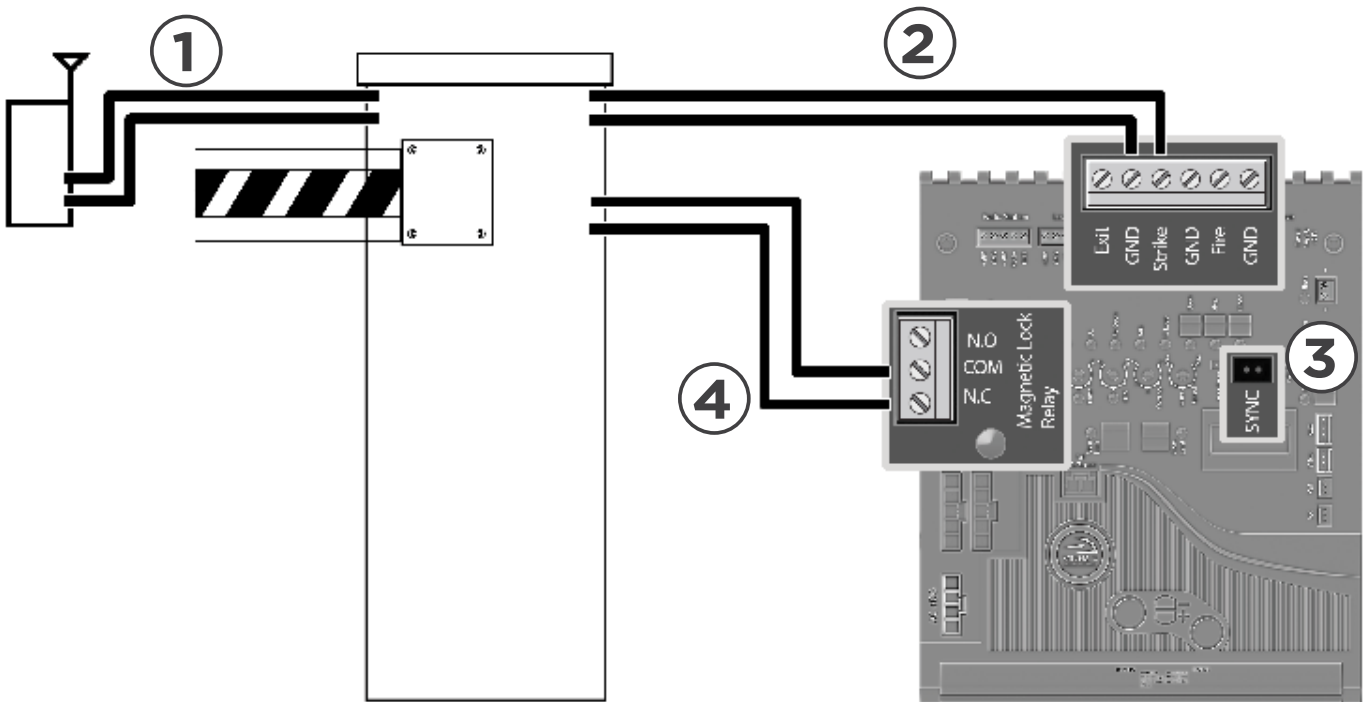

### STEP 3

At the Viking gate operator, activate Sync Mode by placing a jumper on to the pin headers labeled "SYNC".

### STEP 4

Connect Magnetic Lock relay terminals ("COM" and "N.C.") to the Barrier Arms' designated sync input terminals.



# TROUBLESHOOTING

## LED References

Use the table below to identify the corresponding “TS Ref#” and refer to page 38-41 for further troubleshooting.

Pg 41

#	LED	Status	Meaning	TS Ref#(s)
9	“C Loop”	OFF	Normal Condition.	9, 10
		SOLID	Control Board is receiving an input from a device connected to the C Loop terminal (pg 32, 42).	
10	“Open”	OFF	Normal Condition.	9, 10
		SOLID	Control board is receiving an input from a device connected to any of the following input terminals: Exit, Fire, Strike or Open (pg 31, 42).	
11	“STOP”	OFF	Normal Condition.	9, 10
		SOLID	Control Board is receiving an input from a device connected to the Stop, UL or Re-Open terminals (pg 12, 31, 42).	
		FLASHING	There is a problem with the required monitored sensor(s) connected to the “UL” and/or “Re-Open” input terminals (pg 10-11, 23 and 28-29)	
12	“Close”	OFF	Normal Condition.	9, 10
		SOLID	Control Board is receiving an input from a device connected to the Close terminal (pg 31, 42).	
13	“Siren”	OFF	Normal Condition.	11, 13
		SOLID	Second consecutive obstruction has been detected. (pg 24, 26).	
		FLASHING	Batteries are critically low.	
14	“Aux. Pwr”	OFF	No voltage output on these terminals at the moment.	
		SOLID	There is 24VDC output on these terminals at the moment.	
15	“Diagnose”	OFF	Normal Condition.	
		FLASHING	Errors have been detected; Check LCD Display for ERR messages (pg 40).	
16	“Close Limit”	OFF	Gate is not at the close limit position.	6
		SOLID	Gate is at the close limit position.	
		FLASHING	Close limit position has been erased or not set (pg 21-22).	
17	“Open Limit”	OFF	Gate is not at the open limit position.	6
		SOLID	Gate is at the open limit position.	
		FLASHING	Open limit position has been erased or not set (pg 21-22).	
18	“ODS”	OFF	Normal Condition.	11, 13
		SOLID	Obstruction has been detected. (pg 26).	
		FLASHING	Overload has been detected. (pg 26).	
19	“Timer”	OFF	The close timer is turned OFF or gate is not at the open limit if the timer is turned ON. (pg 24).	9, 10
		SOLID	Gate is at Open Limit, Timer is turned ON and counting down to close. (pg 24).	
		FLASHING	Gate is at Open Limit, Timer is turned ON but is not timing out due to a conflicting command. (pg 24).	

# TROUBLESHOOTING

## LCD Display References

The control board is equipped with a LCD Display that provides operator information, current conditions, settings, diagnostics and error messages. Use the table below to identify the corresponding "TS Ref#" and refer to page 41 for further troubleshooting.

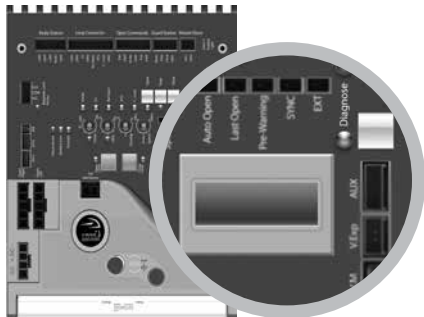

1. Error Messages will be displayed first.
2. The "Diagnose" LED will flash consecutively indicating how many Error Messages are available.
3. Press the Diagnose button to manually scroll through all of the Messages.

Page 41  
TS Ref #s

LCD MSG	Meaning	
MODEL K25	Indicates the Model of the unit	
<b>System Status Messages</b>		
GATE IS IDLE	Gate is stopped between limits	
GATE IS OPENING	Gate is opening	
GATE IS CLOSING	Gate is closing	
GATE IS OPENED	Gate is at the limit open position	
GATE IS CLOSED	Gate is at the limit close position	
STOP BY OBSTRUCT	Gate stopped due to an obstruction sensor event	11, 12, 13
STOP BY OVERLOAD	Gate stopped due to an overload of the gate system	11, 12
OVERLAP TIMING	Gate is waiting for the overlap time	
HOLDING __ SEC	Gate is at the limit open position and timing to close - The display shows the actual time left before closing	
EPS2 OK	While the gate is running, indicates the percentage of accuracy of the EPS. "OK" indicates 100% accurate communication	
UL LEARN UL__ RO__	Indicates the number of connected Monitored Entrapment Protection Sensors that are being monitored. NO LEARN = no sensors learned. (pg 11)	



## LCD Display References

LCD MSG    Meaning

### Multi Meter Displays

MOT AMP  
---- A    This is the motor current amperage during operation.

MOT VOLT  
---- VDC    This is the actual motor voltage during operation.

SOL VOLT  
---- VAC    This is the actual voltage from the solar panel.

CHARGE  
---- VDC    Indicates the voltage being supplied to the Control Board from the Viking Solar Charger.

BAT VOLT  
---- VDC    This is the actual voltage from the Battery

### Board Settings Messages

EPS2  
\_\_\_% ERR    Indicates that the Electronic Positioning Sensor (EPS) needs to be tuned. Error rate is displayed as a percentage

SPEED  
\_\_\_%    Shows the percentage of speed set by the Speed adjustment on the control board. (pg 24)

OVERLAP  
\_\_\_ SEC    Shows the number of seconds set by the Overlap Adjustment on the control board. **This feature is not available on slide gate operator models**

OBS SENS  
----%    Shows the force setting selected to trip the obstruction sensor. (pg 26)

TIMER  
\_\_\_ SEC    Shows the amount time set or remaining to hold the gate at the Open Limit position, before the gate starts to close. (pg 24)

# TROUBLESHOOTING

## LCD Display References

Page 41  
TS Ref #s

LCD MSG	Meaning	
<b>Error Messages</b>		
ERR EPS2 WRONG	The EPS (Electronic Positioning Sensor) has one of the following conditions: a) The EPS is not properly adjusted b) The EPS has a potential connection problem c) The EPS has the wrong cable harness	?
ERR EPS2 MISSING	Missing or damaged EPS2 cable harness	14, 17
ERR ---- LIMIT	Indicates that the open "OPN", close "CLS" or both "NO" limits are cleared and need to be set.	6
ERR FUSE 15 AMP	15 Amp motor fuse is blown	7, 11, 12
ER PANEL LOW	Indicates that the voltage being provided from the solar panel is too low.	?
ER PANEL HIGH	Indicates that the voltage being provided from the solar panel is too High.	?
ER SOLAR NO PANEL	Indicates that there is no voltage being provided from the solar panel	?
ERR NO SOL UNIT	Indicates that there is no voltage being provided from the solar panel.	?
ERR CHRG HIGH	Potential problem with the Solar Charger.	?
ERR BAT LOW	The battery is low	?
ERR SENS UL RO	There is a problem with the required monitored sensor(s) connected to the "UL" and/or "Re-Open" input terminals (pg 10-11, 23, 28-29).	22

# TROUBLESHOOTING

## Solutions

Begin the troubleshooting process by referring to the error messages on the LCD Display and/or the Status LEDs on the control board. Use pages 36-40 to identify the Troubleshooting Reference # (TS Ref#) then reference the table below.

TS Ref#	CHECK	Page Ref#
1	Not applicable to this model.	
2	Not applicable to this model.	
3	Not applicable to this model.	
4	Not applicable to this model.	
5	Check that the Power Harness is connected to the control board.	pg 4, 20
6	Set the limit position.	pg 21-22
7	Check the Motor Fuse on the control board.	pg 4
8	Check that the "Manual Release" switch is turned to the "Engage" position.	pg 3, 11
9	Check the Status LEDs and LCD Display to determine if the control board is receiving an input from any external devices or if the "ODS" has been triggered.	pg 24, 26, 36-38
10	Remove the external devices from the control board to determine if the control board is responding to an input or problem with the external device or wiring.	pg 29-32, 36-37
11	Check the gate, track and chain for any debris or cause for resistance. Check the "ODS" setting on the control board.	pg 8, 12, 26
12	Check that the gate can be moved manually with low resistance throughout its full length of travel.	pg 8, 17
13	Check the limit position.	pg 21-22
14	Check the cable for the Electronic Positioning Sensor for damage. Clean the connection pins.	pg 4
15	Not applicable to this model.	
16	Check the LCD Display for Error Messages.	pg 40
17	Check that the cable from the Electronic Positioning Sensor is connected to the "EPS2" port on the Control Board.	pg 3-4
18	Not applicable to this model.	
19	Manually adjust any setting on the Control Board to clear all wireless override settings.	
20	Not applicable to this model.	
21	Not applicable to this model.	
22	Check the required entrapment protection sensors.	pg 10-11, 23, 28-29
?	Call Viking Technical Support for further assistance.	

# Appendix (A)

## Access Control Connections

### Power Connections

The control board provides a 24VDC output to power external devices and controls. Alternatively, for devices that require a power supply other than 24VDC, the operators Power Box contains a convenient 120VAC receptacle to connect a plug-in transformer.

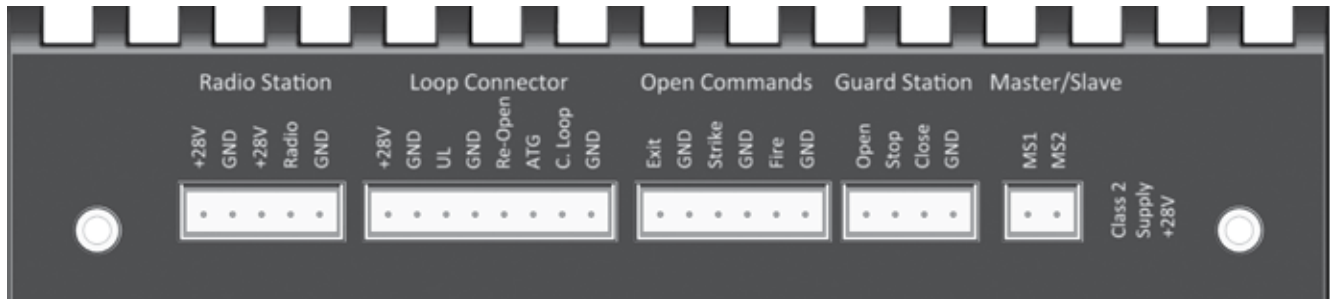

“C”	=	Common
“N.O.”	=	Normally Open

### Terminals Connections and Input Functions:

Viking Terminal	Function	Device Terminal
“+28V”	DC Positive	“+”
“GND”	DC Negative	“-”
“GND”	Relay Common	“C”
“Radio”		“N.O.”
	If “Timer” OFF: Open - Stop - Close	
	If “Timer” ON: Open / Reopen if closing	
“UL”	(see pages 10-11 & 28)	“N.O.”
	If stopped: Prevents the gate from moving	
	If traveling: Stops then reverses gate momentarily	
“Re-Open”	(see pages 10-11 & 29)	“N.O.”
	If stopped: No function	
	If closing: Stops then Opens gate	
“ATG” Anti-Tailgate		“N.O.”
	Input is received: Stops gate if closing	
	Input is released: Closes gate to prevent tailgating	
“C. Loop”		“N.O.”
	If not at open limit: No function	
	If at open limit: Prevents gate from Closing	
“Open”, “Exit”, “Fire” & “Strike”		“N.O.”
	If stopped: Opens gate	
	If closing: Stops then Opens gate	
“Stop”		“N.O.”
	If traveling: Stops gate	
“Close”		“N.O.”
	If stopped: Closes gate	
	If traveling: No function	

**⚠ TECHNICAL TIP:** Each input Terminal (i.e. Radio, Exit, Re-Open, UL) has a corresponding Status LED that when illuminated indicates an input is currently being provided to the terminal and the gate is responding accordingly. (See pages 36-37 LED References)

## Relays In General

**NOTE:** Viking Access Systems does not provide the external safety devices and access controls. These items can be purchased from your dealer or distributor.

### In General

In regards to the Viking control board, all external safety devices and access controls contain, and are, simple relays that provide an input to the Viking control board when the device is activated.

When these devices are activated, their internal relays create a contact, or short, between the “C” and “N.O.” terminals. This contact is what provides the command to the Viking control board.

**▲ TECHNICAL TIP:** Viking uses the Normally Open “N.O.” contact from the device, excluding “fail-safe” type photo beams. In such instances, the Normally Closed “N.C.” will be used instead.

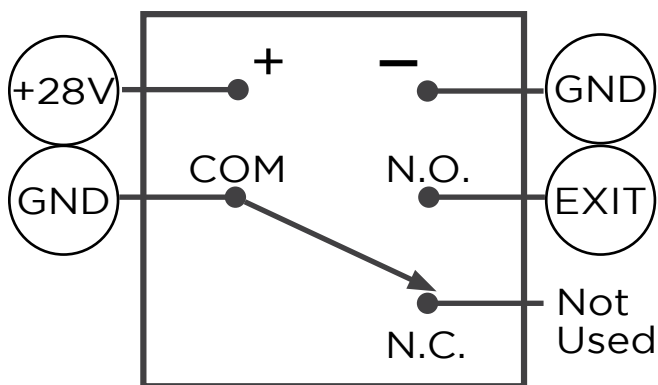

### Glossary of Terms

- 1. Terminal:** Wire Connections.
- 2. Input Terminal:** On the Viking control board, the terminal which is labeled for a specific command (Re-Open, Exit, Radio, etc.). The N.O. contact from the access control device is to be connected to the Input Terminal.
- 3. Terminal Block:** On the Viking control board, a removable block containing multiple terminals.
- 4. Relay:** The component of an access control or safety device that provides an input or command to the Viking control board.
- 5. “C” Relay Common Terminal:** This is the relay terminal that makes contact (a short) to the N.O. terminal when the device is activated. *Always wire this relay terminal to any “GND” terminal at the control board.*
- 6. “N.O.” Relay Normally Open Terminal:** The relay terminal that has an open contact to “C” while the relay is not activated, and a closed contact when the relay is activated. *Almost always wire this relay terminal to an “Input Terminal” at the control board,*
- 7. “N.C.” Relay Normally Closed Terminal:** The relay terminal that has a closed contact to “C” while the relay is not activated, and an open contact when the relay is activated. *This terminal is rarely used.*
- 8. Relay Coil:** Contains the terminals that provide power at the relay.
- 9. “+” Relay Positive Terminal:** The positive power pole for the relay coil. *Always wire this relay terminal to any “+28V” terminal at the control board.*
- 10. “-” Relay Negative Terminal:** The negative power pole for the relay coil. *Always wire this relay terminal to any “GND” terminal at the control board.*

# Appendix (B)

⚠ Cable use in Class 2 circuit to an external device shall be type CL2, CL2P, CL2R, CL2X or other cable with equivalent or better electrical, mechanical, and flammability ratings.

## Common Radio Receivers - Connections

Multi Code \*099

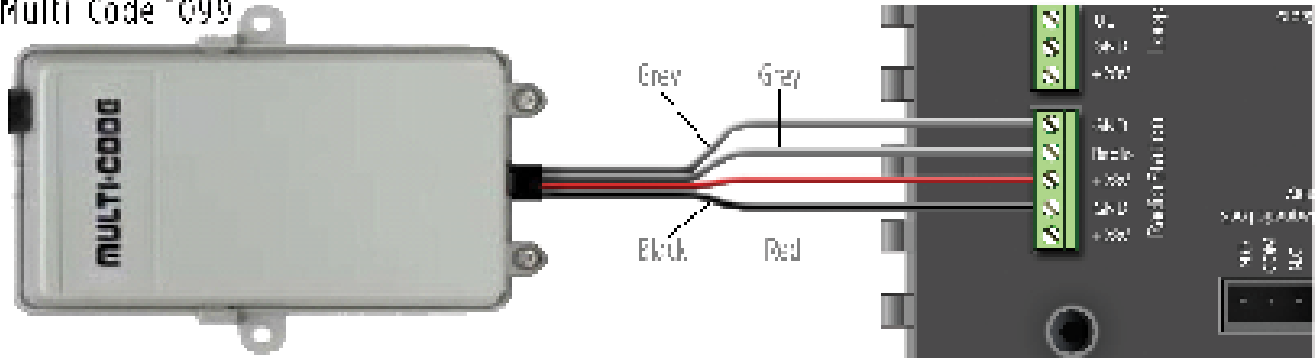

Multi Code \*090

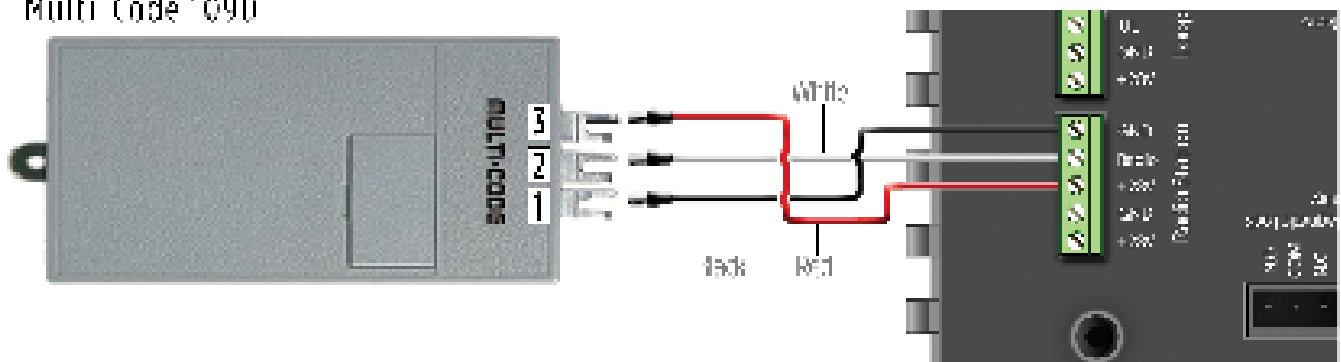

Liftmaster 317HM

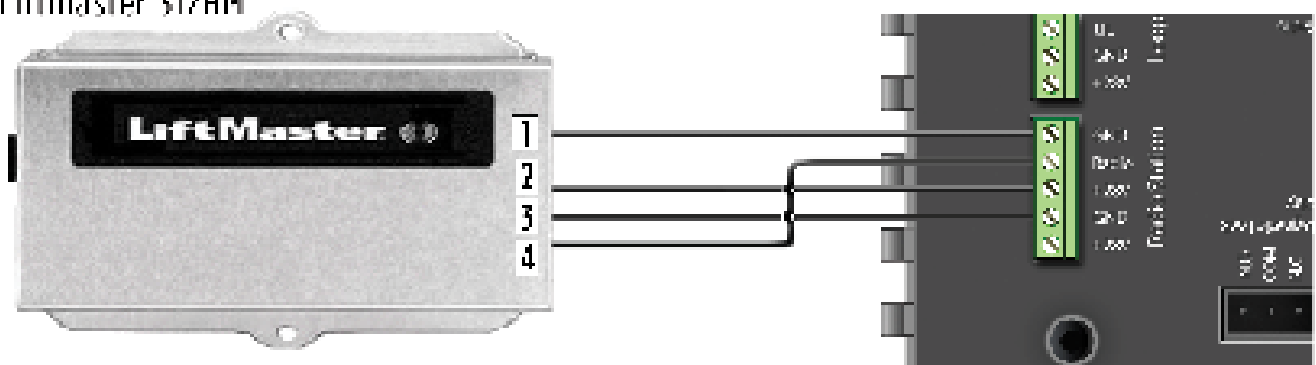

Linear Della 3 GRD

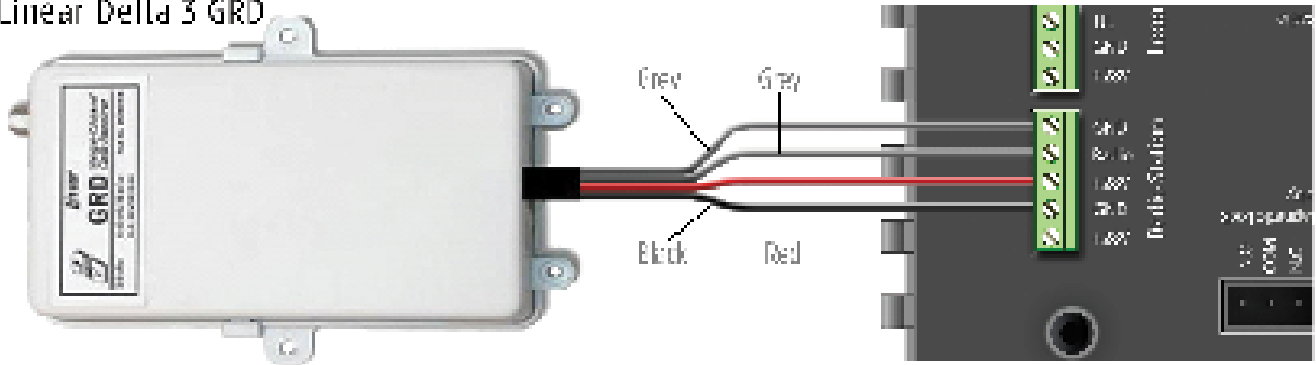

**(THIS PAGE LEFT BLANK INTENTIONALLY)**

# VIKING EXPANSION PRODUCTS



## VIKING SOLAR Related Components:

**12V 40W Solar Panels** Part# VA-S040W

**12V 35Ah batteries** Part# DUBA35

**⚠ NOTE:** The number of cycles achieved are dependent upon the following and may require increased panel and battery capacities:

- Power consumption of all accessories being used
- Average solar radiation of geographic location



# OUR CONTINUOUS COMMITMENT TO EXCELLENCE

Viking Access Systems is continuously working hard to identify and design products that will appeal to the industry and its needs. As technology continues to advance, we have developed a completely efficient and intelligent line of gate operators to meet the changing demands. These machines offer: full UL325 and UL991 compliance, soft-start and soft-stop, intelligent obstruction sensors, continuous operation (100% duty cycle) and extreme power efficiency. Innovative features include: adaptive and self-learning algorithms, redundancy design in both hardware and software to ensure operation and functionality, protection from lightning, short circuit and power surges, and our exclusive drive-train design offering the highest efficiency rating in the industry. Our entire product line is continually modified and improved based on the latest technology and our customer's valuable feedback. The results are products that offer accuracy, efficiency, reliability and performance, all in sleek, high-tech designs.

We pledge to continue establishing ourselves as the leader in high quality, innovative gate operators by developing "Next Level" technology. We are committed to providing safety and convenience with innovative solutions for every security gate need.



# STANDARD FEATURES

- Single 12V battery and single 12V solar panel operation.
- Most Advanced Charging System in the industry.
- Power Saving Technology minimizes current draw.
- Viking Solar Power Management System maximizes the number of cycles per day
- Sleep Mode for non-essential accessories minimizes current draw on stand-by.
- High Efficiency Electro-Mechanical Design increases the number of cycles per day.
- Twice, or more, the number of cycles per day, with a 10W solar panel, compared to other manufacturers.
- Real Time Status Display of the solar panel voltage, charging voltage and battery voltage.
- 5 years limited warranty (Visit our website for more details).
- Built-in protection against lightning strikes or similar electrical surges
- Inherent Overload Protection; Redundancy Design with multiple types of protection.
- Zinc Plated and Powder Coated steel chassis.
- Easy access to manual operation, allowing the gate to be move by hand, independently of the operator.
- Fast and easy installation process.
- Convenient Digital Limit set up.
- Modular connectors for easy access control and accessory installation.
- LCD display for monitoring and diagnostic purposes.
- Self Diagnose Features conveniently displays any errors in the system.
- Made in USA.

INSTALLATION DATE: \_\_\_\_\_

COMPANY / INSTALLER: \_\_\_\_\_

CONTACT: \_\_\_\_\_

SERIAL NUMBER(S): \_\_\_\_\_

ALL INSTALLATION, MAINTENANCE AND REPAIR WORK MUST BE DOCUMENTED AND MADE AVAILABLE TO THE USER.



**VIKING ACCESS SYSTEMS**

631 Wald Irvine, CA 92618

Phone 800.908.0884

Fax 949.753.1640

[www.vikingaccess.com](http://www.vikingaccess.com)